



# SHOW PROGRAMS 2001-2005

The 52nd Street Project gratefully acknowledges the support of the following foundations and corporations: ABNY Foundation, Barker Welfare Foundation, The Bamsley Foundation, Broadway Play Publishing, Carnegie Corporation of New York, Comedy Central, Consolidated Edison, The Dammann Fund, The Dramatists Guild Fund, Dramatists Play Service, Eleanor, Adam & Mel Dubin Foundation, The Educational Foundation Of America, Entertainment Weekly, Ford Foundation, The Fan Fox & Leslie R. Samuels Fdn., Gap Inc., GLADPZ Foundation, The Horace W. Goldsmith Foundation, The Florence Gould Foundation, The William & Mary Greve Foundation, Heights Partners, The Holland Lodge Foundation, Inc., Hudson Scenic Studio, Betty E. & George B. Kaiser Foundation, Rita J. and Stanley H. Kaplan Foundation, Lloyds TSB Bank plc, Luca, Inc., James A. Macdonald Foundation, Ann M. Martin Foundation, J.P. Morgan Charitable Trust, Mosaic Entertainment, The New World Foundation, The New York Times Co. Fdn., Newman's Own, O'Grady Family Foundation, Laura Pels Foundation, Staging and Design, Inc., Harold & Mimi Steinberg Charitable Trust, The Surdna Foundation, Susquehanna, Tandler Textile Inc., Uniwold Group Inc., John A. Vassilaros & Sons, Inc, The Vervane Foundation, West Bank Cafe, The Wiener Family Foundation, Yorke Construction Corporation. In addition the following individuals made gifts of over \$150 this year (list is current as of 1/24/01)

Anonymous  
Liliana Amador-Martí  
& Frank Marty  
May Ameen  
Peter Askin  
June Ballinger & Michael Goldstein  
Ben Barenholtz  
Jessica Bauman  
Laurie Becker & Rick Sweren  
Meredith Beeuwkes  
Lisa Benavides & Tim Nelson  
Stephanie Berger & Paul King  
Scott Bergman  
Brett Berk  
Pam Berlin & Billy Carden  
Arthur & Sandra Bernard  
Barry & Myra Bernard  
Alexander & Elizabeth Bernstein  
Vicky Bijur & Ed Levine  
Lewis Black  
Jeanette & Samuel Black  
Richard Blackstone  
& Yldez Yuksek  
Tessa Blake  
Audrey Bloch & Joseph Wiesenthal  
Robi & Ruth Blumenstein  
Buzz Bovshow  
Becky Browder & Ted Neustadt  
Deborah Brown  
Susan Bruce & Peter Hedges  
John Burt  
Kate Burton & Michael Ritchie  
Joseph & Hilary Califano  
Linda & Arthur Carter  
Rachel Chanoff  
Glenda Chesshir  
Ethan Coen & Trish Cooke  
Lietla Hesen-Cohen & Richard Cohn  
Thomas Cott  
Margaret Crimmins  
Colleen Croft & Louis Balducci  
Stephen & Sandra Crudgington  
Willem Dafeo & Liz Lecompte  
Arthur Dantchik  
Peter & Judith Dawkins  
Edward & Joanne DiRugieris  
Alex Draper & Lorraine Tobias  
Richard & Rebecca Dresser  
Christopher & Karen Eddowes  
Mario Egozi  
David Eigenberg  
Ned Eisenberg  
Barbara Ettinger  
Barbara Ettinger & Sven Huseby  
Heidi Ettinger  
Wendy Ettinger & Derek McLane  
Adam Felber & Jeanne Simpson  
Gerald Fernandez  
Peter Jay Fernandez  
& Denise Burse  
Hannah Finn & John Wiltshire  
Alexa Fogel  
Tom Fontana & Sagan Lewis  
Katherine Foster  
David Frankel

Eric & Juli Frankel  
Richard Frankel & Kathleen Clark  
Naomi Freundlich & Charles Miles  
Geraldine R. Frey  
Louis & Patrice Friedman  
Hank Gallo  
Victor Garber  
Beth Gardiner  
Rose Gasner & Larry Chertoff  
Joseph & Margaret Gazzdak  
John A. Vassilaros  
& Alexandra Gersten  
Ileen Getz & Mark Grinnell  
Nancy Giles  
Lloyd & Kilty Gilmour  
Judy Goldman & Michael Pillingier  
Tony Goldwyn & Jane Musky  
Stephen & Cathy Graham  
Connie Grappo & Lee Wilkof  
Michael Greif & Jonathan Fried  
Emily Grishman  
& Susan Sampliner  
Rebecca & Peter Grunwald  
Lisa Gugenheim  
Evan Handler  
Stuart & Lorna Hayim  
Peter Herdrich & Karen Trott  
William Holtzman  
& S. Sylvia Shepard  
Barnard Hughes  
& Helen Stenborg Hughes  
Andrew Hurwitz & Dana Segal  
Dana Ivey  
Sy Jacobs  
Whitney Scott & Peter Jacobson  
Macon R. & Michael B. Jessop  
Amanda Johns  
Julia A. Johns  
Andrea Johnson  
Traci Paige Johnson  
& Robert Mowen  
Cherry Jones & Mary O'Connor  
Larry & Mary Jones  
Maurice Kanbar  
Ronald Kastner  
Susan Kaufman  
Mark Keoppen & Wendy Townsend  
John Kirtley  
Seth & Beth Klarman  
Joana & Jason Klot  
Mary Kong  
Judy Kuhn & David Schwab  
Roger & Belle Kuhn  
Michael A. Lane  
Mark Lanow & Joanne Astrow  
Allan & Nanette Larson  
Jill Larson  
Kate Lear & Jonathan LaPook  
Mitchell Lemsky & Jane Bodle  
Robert Sean Leonard  
Joshua Lewis  
Mark Linn-Baker & Adrienne Lobel  
Jessica Lissy  
John Bedford Lloyd  
& Anne Twomey

Chris & Sally Lutz  
John Lyons  
Marsue & Peter MacNicoll  
Greg MacPherson  
& Jane Perlmutter  
Joseph Maffia  
Roma Maffia  
Rusty Magee & Alison Fraser  
Paul & Lauren Mandell  
Brian & Marsha Mannain  
Elizabeth Manne  
Peter Manning & André Bishop  
Donald Margulies & Lynn Street  
Ali Marsh  
Tory & Howie Masters  
Kay Matschullat & Allan Arffa  
Max Mayer & Catherine Corpeny  
Drew McCoy & Amy Aquino  
Paul McCrane & Dana Kellin  
James & Hannelore McDaniel  
Fran McDormand & Joel Coen  
Brian Mertes  
Bette Midler  
Patricia Miller & Chris McFarland  
Isaac Mizrahi  
Ross & Beth Moore  
Walter Mosley  
Michaela Murphy  
& Larry Nathanson  
Patricia M. Murphy, Esq.  
& Adam Spilka  
Randy & Rona Nelson  
Ruth Nelson  
Mark Nesselson, M.D.  
& Elliott Rosenblum  
Cynthia Nixon  
Steven O'Neill  
Kevin O'Rourke & Edith Thurber  
Carol Ochs & Bruce MacVittie  
Paul & Maria Onderdonk  
Steven & Margot Peter  
Elizabeth Peters  
Bat-Sheva & Thomas Peters  
Ethan Phillips  
Susan Ochs Phillips  
Virginia Pike  
Oliver Platt  
& Camilla Campbell Platt  
Richard Polatchek  
Jeremy Posner  
Dean & Leslie Potashner  
Gigi Pritzker Pucker  
& Michael Pucker  
Christopher Randolph  
Peter & Helen Randolph  
Anthony Ranieri  
Paul Reale & Barbara McCrane  
Willie Reale & Jenny Gersten  
Theresa Rebeck & Jess Lynn  
Alysia Reiner & David Basche  
Jacquelyn Reingold  
Todd Richter & Donna Plummer  
Herald & Linda Ritch  
David & Anita Rogerson  
Robin Morse & Gus Rogerson

Daryl Roth  
Donald Rothschild  
& Lottchen Shivers  
Kenneth Rothstein  
Steve Sabba  
Richard & Madeline Salzman  
Laura Sametz  
Tim & Lisa Sanford  
Joshua Sapan  
Stacey Schaffer & Eric Schwartz  
Karin & Tom Schall  
Leslie Schine & Nils Nilsen  
Glyna & Neil Schlesinger  
Beth Schneider  
Maury Schott  
Marc Segan  
Mitchell Semel & Colleen Carroll  
Aaron & Elaine Shapiro  
Bernice Baruch Shawl  
Andrew & Helen Sheinman  
Jan Sidebotham & Tim Emerson  
Meg Simon  
Landon Slane  
Tom Slaughter & Marthe Jocelyn  
Ken Smith  
Phillip K. & Gloria W. Smith  
Abigail Rose Solomon  
Dr. David Solowiejczyk  
José & Michelle Soto  
Dorothy Spears & Vance Brown  
Jeff Stafford  
John Steber & Robert Shaffron  
Jean Stein  
Anne Meara & Jerry Stiller  
Susanna Styron & Darrell Larson  
Daniel Sweet  
Mariko Tada  
Jay & Rachel Tarses  
Mary Lou Teel & Peter Freundlich  
Joan Vail & John Thorne  
Tracy Thorne & Edmund Lewis  
John & Katherine Turturro  
Laura Valeroso & David Seidman  
Katrina vanden Heuvel  
Wendy vanden Heuvel  
& Brad Coley  
William & Melinda vanden Heuvel  
John A. Vassallo  
Mary Pat Walsh  
Borah & Mildred Walton  
Sally & Lenny Weiss  
Gregory Welch  
Jane Bolster & Steve Wertimer  
Donna & Walter Wick  
Jenny Wiener  
Michael & Zena Wiener  
Matt Williams & Angelina Fiordellisi  
Jan Wilson & Saula Cutter  
Donald Windham  
Joanne Woodward & Paul Newman  
Anne & Charles Wright  
Jeffrey & Janine Yass  
James & Mary Lin Yoshimura  
Ailyn Yuksek  
Virginia Zakian & Robert Sandberg

# The 52nd Street Project Presents



## TALKING SHOP: PLAYS THAT WORK



## The 2001 Two-on-Twos

January 26 at 7:30 p.m.  
Jan. 27 at 3:00 & 7:30 p.m.  
Jan. 28 at 3:00 p.m.

The Ensemble Studio Theatre  
549 W. 52nd St.

*The 2001 Two-on-Twos*  
**Talking Shop: Plays that Work**  
 The Ensemble Studio Theatre - Jan. 26-28, 2001



**The 52nd Street Project Staff**

Gus Rogerson, Artistic Director  
 Carol Ochs, Executive Director  
 Michael Bernard, Associate Artistic Director  
 John Sheehy, Director of Development and Marketing  
 George Roman Babiak, Production Manager  
 Julie Feldman, Director of Education  
 Megan Sandberg-Zakian, Volunteer Coordinator  
 Chris Ceraso, Teen Dean  
 Iris A. Brown, Graphic Designer  
 Mayleen Cancel and Lorraine Zambrano, Receptionists  
 Interns: Liz Bell, Jennifer Boring, Emily Crow

**Production Staff**

**Composer:** Patrick Barnes  
**Set Designer:** Kevin Joseph Roach  
**Lighting Designer:**  
 Greg MacPherson  
**Costume Designer:**  
 Anney McKilligan  
**Sound Designer:** Maury Schott  
**Stage Manager:** Jenny Peek  
**Slide Design Team:**  
 Monty Nicol, Kim Snow, Kevin Coffey,  
 Katherine Lumb, Vickie Clarke

**Prop Design Team:**

Megan Bartholomay, Jennifer Boring,  
 Emily Crow, Kate Hancock,  
 Jenny Peek,

**"Talking Shop" Illustrations:**

James Stevenson

**Furniture Crew:**

Emily Crow, Luis Anthony Maldonado

**Prop Crew:**

Kate Hancock, Diana Rojas

**Slide Projector Apparatus**

**Manager (SPAM):**

Jennifer Boring

**Load-in and Light-hang Crew:**

Jennifer Boring, Bill Charlton,  
 Emily Crow, Doug Lockwood,  
 Matt Maher, Jill Robbins, Tom Schall,  
 John Sheehy, Vanessa Valdes,  
 Becky White

**House Managers:**

Karin Schall, Mary Pat Walsh,  
 Beth Emelson

**Weekend-away Host & Guest Chef:**

Maria Tucci

**Weekend-away chefs:**

Carol Ochs,  
 John Sheehy

**COOL STUFF ON SALE  
 IN THE LOBBY!**

The Fabulous Flyer Bar .....\$2.00 & \$1.50  
*and featuring Shel Silverstein's "Five and Twoey" logo:*  
 Project T-shirts (short sleeve) .....\$12.00  
 Project T-shirts (long sleeve) .....\$15.00  
 Project Caps .....\$15.00  
 Project Mugs .....\$5.00  
 Project Pencil 3-pack (now in RED!) .....\$1.00

Thank you for coming to **TALKING SHOP!** If you are not on our mailing list (or if your address has changed), please fill out this form and give it to us on your way out or mail it to the address below. We would also like to know if you are interested in becoming a volunteer. We need help in *all areas*, so be sure to fill out the entire form.

**PLEASE ADD ME TO YOUR MAILING LIST:**

1/01

NAME: \_\_\_\_\_

ADDRESS: \_\_\_\_\_

ZIP \_\_\_\_\_

HOME PHONE: \_\_\_\_\_

DAYTIME PHONE: \_\_\_\_\_

E-MAIL ADDRESS: \_\_\_\_\_

MY OCCUPATION: \_\_\_\_\_

MY HOBBIES: \_\_\_\_\_

**YES, I WOULD LIKE TO BE OF HELP. I CAN:**

- |   |   |  |
|---|---|--|
| <input type="checkbox"/> Help load in and out for shows | <input type="checkbox"/> Draw and/or paint  | <input type="checkbox"/> Help kids with homework |
| <input type="checkbox"/> Hang lights                    | <input type="checkbox"/> Help with mailings | <input type="checkbox"/> Teach kids a skill      |
| <input type="checkbox"/> Work on a backstage crew       | <input type="checkbox"/> Do office work     | <input type="checkbox"/> Be a chef at an event   |
| <input type="checkbox"/> Do graphic design              | <input type="checkbox"/> Design sound       | <input type="checkbox"/> Design and sew costumes |
| <input type="checkbox"/> Other (please specify) _____   |   |  |

**MY SCHEDULE IS:**

- Very flexible. I'm often available during weekdays.  
 Somewhat flexible. I can help on the occasional morning or afternoon during the week.  
 Not very flexible at all, but I've got some free time on evenings and weekends.

If you would like to mail this (and you're always welcome to enclose a tax-deductible contribution), you can send it to: **The 52nd Street Project**, 500 West 52nd St., New York, NY 10019. Or fax it to (212) 333-5598.



NATIONAL  
 ENDOWMENT  
 FOR THE ARTS

The Two-on-Two Program is made possible with public funds from the National Endowment for the Arts; The New York State Council on the Arts, a state agency; the Department of Youth and Community Development; and the New York City Department of Cultural Affairs. The 52nd Street Project is a member of Art/NY.

State of the Arts



NYSCA

## Don't Miss Our Upcoming Shows!

### 2001 Sonnet Scenes

Co-written by William Shakespeare and  
the teens of the 52nd Street Project

Saturday, Feb. 10th at 7:30 p.m. and  
Sunday, Feb. 11th at 3:00 p.m.

at the Women's Interart Annex  
500 W. 52nd St., #2A

(Just across the hall from the Clubhouse)

Call (212) 333-5252 for reservations.

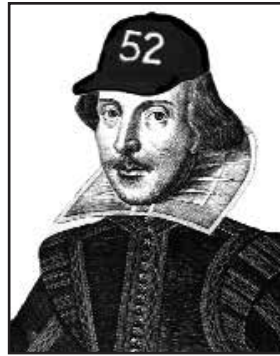

## JUST ASKIN'! THE CURIOSITY PLAYS

The Winter Playmaking Plays  
March 23-25 at  
HB Playwright's Foundation

This month, a fresh batch of newcomers began our 8-week Playmaking program. At the end of the class they will be whisked away to Kent, Connecticut for a weekend in which they will fashion 10 brand new plays featuring your favorite Project adult actors.

HONORARY CO-CHAIRS GINA TORRES AND LAURENCE FISHBURNE INVITE YOU TO

**SAVE THE STARDATE: MAY 7, 2001**

# 52001:



## THE 52ND STREET PROJECT'S SPACE BENEFIT

**IN SPACE NO ONE CAN HEAR YOU SCREAM WITH LAUGHTER!**

For information or reservations call  
Commander John Sheehy at (212) 333-5252.

The 52nd Street Project is a non-profit organization that brings inner-city children from the Hell's Kitchen neighborhood together with professional theater artists to create original theater. **Talking Shop** is a production of our Two-on-Two program, in which two of the Project's more seasoned kids are matched with two adult volunteers (one playwright, one director) and given the task of creating a short play. After the writers presented their contributions, the actors and directors traveled to Dutchess County earlier this month to rehearse the plays over a three-day weekend. Tonight's performance is the final result.

The Project is delighted to return to the **Ensemble Studio Theatre**, where we have been performing since our inception in 1981. We gratefully acknowledge that if E.S.T. wasn't here, we'd be nowhere.

### The 52nd Street Project Board of Directors

Ben Barenholtz

Lisa Benavides

Rachel Chanoff

Heidi Ettinger

Wendy Ettinger, *chair emeritus*

Louis P. Friedman

Stephen Graham

Larry Jones

James McDaniel

Frances McDormand, *chair*

Patricia M. Murphy, Esq.

Carol Ochs

Willie Reale

Gus Rogerson

José Soto, Jr.,

*alumni boardmember*

Pamala Tyson

Laura Valeroso

Wendy vanden Heuvel

Jenny Wiener

### Special Thanks

We're grateful to Curt, Jamie, Eliza, Tim, and the rest of the staff at The Ensemble Studio Theater for making their theater available to us. Maria Tucci, Alice Provenson, Stephen Perpeluk and Terry Fitzpatrick, and Derek McLane and Wendy Ettinger graciously allowed us to use their upstate homes for three tumultuous, but fun-filled days.



Help build the Clubhouse Library! Buy us a book or two from **Amazon.com** by logging on to our on-line "wish list." Scroll down the right side of their home page and click on WISHLIST, then type "project52@aol.com" into the email search field. Then just click away to stock our stacks!

# Talking Shop: Plays That Work - ACT I

All music composed by Patrick Barnes

## Jest Friends

By Robert Shaffron. Directed by John Steber.

Larry ..... Peter Granados  
Moe ..... Johnathan Roldan  
Princess ..... Diana Rojas  
Herald ..... Gus Rogerson

“Put The Fun in Funny” lyrics by Robert Shaffron.

## What’s In Your Shopping Bag?

By Regina Porter. Directed by Martha Banta.

Mannequin ..... Mona Lisa Barthelemy  
Solace ..... Felicita Jerez  
Boy ..... Luis Anthony Maldonado

“Being Truly Glamorous” lyrics by Regina Porter & John Sheehy.

## Betty and The Brute

By George Babiak. Directed by Josh Lewis.

Betty ..... Anju Andre-Bergmann  
The Brute ..... Steven Vasquez  
Vince ..... Josh Lewis  
Manny from Massapequa ..... Luis Anthony Maldonado  
Wendy from Weehawken ..... Keira Naughton  
Pete from Piscataway ..... George Babiak

“Betty and The Brute Theme” and “Maintain Your Equilibrium” lyrics by George Babiak.

☞ **Intermission!** ☜

# ACT II

## Do The Math

by Theresa Rebeck. Directed by Jenny Pollack.

Bibi ..... Lorraine Calderon  
Nina ..... Marlene Moran  
Store clerk ..... Emily Crow

“Friends Forever” lyrics by Theresa Rebeck.

## Work With Me

by Oni Faida Lampley. Directed by Keira Naughton.

Louis ..... Justin Aponte  
Violetta ..... Shevonne Hernandez  
Nurse ..... Luis Anthony Maldonado

“A Reggae Rage” lyrics by John Sheehy.

## The Legend of Duke Hogwallar

By Jerome Hairston. Directed by Jonathan Bernstein.

Duke Hogwallar/Piglet Paul ..... Robert Tomas  
Piglet Pete/Duke Hogwallar II ..... Michael Feliciano  
The Farmer ..... George Babiak  
Vern ..... Josh Lewis

“There Ain’t No Spookin’ The Duke” lyrics by Jerome Hairston.

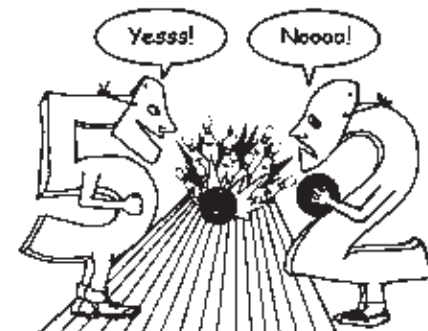

The **52nd Street Project Teen Ensemble** is a two-year program for graduates of The Project's writing and acting classes. The Teen Ensemble focuses on professional level acting technique by using both original and existing texts. The culmination of the program is the performance of a play by William Shakespeare as seen through the eyes of the kids in the class. The most recent teen production, **Midsummer Night's Dream**, was performed in the summer of 2000 at **Theatro Technis** in London and the **Chateau de Berne** in Lorgues, France. The teens you see tonight will journey to London this summer to present their own version of **The Tempest**.

### The Project Staff

Gus Rogerson .....Artistic Director  
 Carol Ochs .....Executive Director  
 Michael Bernard .....Associate Artistic Director  
 John Sheehy .....Director of Development  
 George Roman Babiak .....Production Manager  
 Julie Feldman .....Director of Education  
 Megan Sandberg-Zakian .....Volunteer Coordinator  
 Chris Ceraso .....Teen Dean  
 Iris A. Brown .....Graphic Designer  
 Mayleen Cancel, Lorraine Zambrano .....Receptionists  
 Jennifer Boring, Emily Crow, Kate Hancock .....Interns

### The 52nd Street Project Board of Directors

Ben Barenholtz	Patricia M. Murphy, Esq.
Lisa Benavides	Carol Ochs
Rachel Chanoff	Willie Reale
Heidi Ettinger	Gus Rogerson
Wendy Ettinger, <i>chair emeritus</i>	José Soto, Jr., <i>alumni boardmember</i>
Louis P. Friedman	Pamala Tyson
Stephen Graham	Laura Valeroso
Larry Jones	Wendy vanden Heuvel
James McDaniel	Jenny Wiener
Frances McDormand, <i>chair</i>	

The Project would like to thank: Fran McDormand and Susan Ross for hosting us upstate during a weekend of writing; Margot Lewitin, Paul Smithyman, and all the folks at Women's Interart for generously allowing us to use their space.

## The 52nd Street Project Presents



# 2001 Sonnet Scenes

*Co-written by William Shakespeare  
 and the Teens of the 52nd Street Project*

*Saturday, Feb. 10th at 7:30 p.m.*

*Sunday, Feb. 11th at 3:00 p.m.*

*at the Women's Interart Annex*

*Funded in part by The Surdna Foundation*

# 2001 Teen Sonnet Scenes

## The Sun and the Rainbow

By Sahara Walsh from Sonnet #26

Directed by Melissa Bowen, Dramaturgy by Abigail Lopez

Soleil .....Sahara Walsh  
Suzette .....Catherine Mueller  
Kevin .....Alex Metzler

## White Lady

By Deshana Hamid from Sonnet #147

Dramaturg/Directors: Roz Coleman and Megan Sandberg-Zakian

Ebony .....Deshana Hamid  
Alexis .....Roz Coleman  
Rosaria .....Judy Agosto  
Michelle .....Tessa John-Connor

## Learning To Trust

By Alex Metzler from Sonnet #23

Dramaturg/Director: Buzz Bovshow

Rob .....Alex Metzler  
Alice .....Tessa John-Connor  
Nick .....Thomas Santoni  
Nina .....Melissa Bowen

## As the Kingdom Turns

By Mary Vamvoukakis from Sonnet #35

Directed by Catherine Mueller, Dramaturgy by Enid Graham

Princess .....Mary Vamvoukakis  
Inventor .....George Babiak  
King .....Buzz Bovshow  
Guard .....John Sheehy  
People of Kingdom .....Ensemble

## The Telegram

By Tessa John-Connor from Sonnet #64

Directed by Chris Ceraso, Dramaturgy by Annie Torsiglieri

Carrie .....Tessa John-Connor  
Miguel .....Thomas Santoni  
Postal Worker .....Melissa Bowen

## Crushes

By Judy Agosto from Sonnet #29

Dramaturg/Director: Megan Sandberg-Zakian

Haze .....Judy Agosto  
Victoria .....Deshana Hamid  
Damion .....Alex Metzler

## My First Love

By Thomas Santoni from Sonnet #44

Directed by Michael Bernard & Chris Ceraso,

Dramaturgy by Chris Ceraso

Thomas .....Thomas Santoni  
Jake .....Alex Metzler  
Marissa .....Mary Vamvoukakis  
Carmen .....Judy Agosto  
Teacher (offstage) .....Chris Ceraso  
Fly Honey 1 .....Roz Coleman  
Fly Honey 2 .....Deshana Hamid

Stage Manager and Sound Designer:

Jennifer Boring

Light Operator and Prop Handler:

Emily Crow

**Intermission!**

The 52nd Street Project gratefully acknowledges the support of the following foundations and corporations: ABNY Foundation, Barker Welfare Foundation, The Bamsley Foundation, Broadway Play Publishing, Carnegie Corporation of New York, Comedy Central, Consolidated Edison, The Dammann Fund, The Dramatists Guild Fund, Dramatists Play Service, Eleanor, Adam & Mel Dubin Foundation, The Educational Foundation Of America, Entertainment Weekly, Ford Foundation, The Fan Fox & Leslie R. Samuels Fdn., Gap Inc., GLADPZ Foundation, The Horace W. Goldsmith Foundation, The Florence Gould Foundation, The William & Mary Greve Foundation, Heights Partners, The Holland Lodge Foundation, Inc., Hudson Scenic Studio, Betty E. & George B. Kaiser Foundation, Rita J. and Stanley H. Kaplan Foundation, Lloyds TSB Bank plc, Luca, Inc., James A. Macdonald Foundation, Ann M. Martin Foundation, J.P. Morgan Charitable Trust, Mosaic Entertainment, The New World Foundation, The New York Times Co. Fdn., Newman's Own, O'Grady Family Foundation, Laura Pels Foundation, Staging and Design, Inc., Harold & Mimi Steinberg Charitable Trust, The Surdna Foundation, Susquehanna, Tandler Textile Inc., Uniwold Group Inc., John A. Vassilaros & Sons, Inc, The Vervane Foundation, West Bank Cafe, The Wiener Family Foundation, Yorke Construction Corporation. In addition the following individuals made gifts of over \$150 this year (list is current as of 1/24/01)

Anonymous	Eric & Juli Frankel	Chris & Sally Lutz	Daryl Roth
Liliana Amador-Martí	Richard Frankel & Kathleen Clark	John Lyons	Donald Rothschild
& Frank Marty	Naomi Freundlich & Charles Miles	Marsue & Peter MacNicol	& Lottchen Shivers
May Ameen	Geraldine R. Frey	Greg MacPherson	Kenneth Rothstein
Peter Askin	Louis & Patrice Friedman	& Jane Perlmutter	Steve Sabba
June Ballinger & Michael Goldstein	Hank Gallo	Joseph Maffia	Richard & Madeline Salzman
Ben Barenholtz	Victor Garber	Roma Maffia	Laura Sametz
Jessica Bauman	Beth Gardiner	Rusty Magee & Alison Fraser	Tim & Lisa Sanford
Laurie Becker & Rick Sweren	Rose Gasner & Larry Chertoff	Paul & Lauren Mandell	Joshua Sapan
Meredith Beeuwkes	Joseph & Margaret Gazzdak	Brian & Marsha Mannain	Stacey Schaffer & Eric Schwartz
Lisa Benavides & Tim Nelson	John A. Vassilaros	Elizabeth Manne	Karin & Tom Schall
Stephanie Berger & Paul King	& Alexandra Gersten	Peter Manning & André Bishop	Leslie Schine & Nils Nilsen
Scott Bergman	Ileen Getz & Mark Grinnell	Donald Margulies & Lynn Street	Glyna & Neil Schlesinger
Brett Berk	Nancy Giles	Ali Marsh	Beth Schneider
Pam Berlin & Billy Carden	Lloyd & Kilty Gilmour	Tory & Howie Masters	Maurly Schott
Arthur & Sandra Bernard	Judy Goldman & Michael Pillingier	Kay Matschullat & Allan Arffa	Marc Segan
Barry & Myrna Bernard	Tony Goldwyn & Jane Musky	Max Mayer & Catherine Corpeny	Mitchell Semel & Colleen Carroll
Alexander & Elizabeth Bernstein	Stephen & Cathy Graham	Drew McCoy & Amy Aquino	Aaron & Elaine Shapiro
Vicky Bijur & Ed Levine	Connie Grappo & Lee Wilkof	Paul McCrane & Dana Kellin	Bernice Baruch Shawl
Lewis Black	Michael Greif & Jonathan Fried	James & Hannelore McDaniel	Andrew & Helen Sheinman
Jeanette & Samuel Black	Emily Grishman	Fran McDormand & Joel Coen	Jan Sidebotham & Tim Emerson
Richard Blackstone	& Susan Sampliner	Brian Mertes	Meg Simon
& Yldez Yukse	Rebecca & Peter Grunwald	Bette Midler	Landon Slane
Tessa Blake	Lisa Gugenheim	Patricia Miller & Chris McFarland	Tom Slaughter & Marthe Jocelyn
Audrey Bloch & Joseph Wiesenthal	Evan Handler	Isaac Mizrahi	Ken Smith
Robi & Ruth Blumenstein	Stuart & Lorna Hayim	Ross & Beth Moore	Phillip K. & Gloria W. Smith
Buzz Bovshow	Peter Herdrich & Karen Trott	Walter Mosley	Abigail Rose Solomon
Becky Browder & Ted Neustadt	William Holtzman	Michaela Murphy	Dr. David Solowiejczyk
Deborah Brown	& S. Sylvia Shepard	& Larry Nathanson	José & Michelle Soto
Susan Bruce & Peter Hedges	Barnard Hughes	Patricia M. Murphy, Esq.	Dorothy Spears & Vance Brown
John Burt	& Helen Stenborg Hughes	& Adam Spilka	Jeff Stafford
Kate Burton & Michael Ritchie	Andrew Hurwitz & Dana Segal	Randy & Rona Nelson	John Steber & Robert Shaffron
Joseph & Hilary Califano	Dana Ivey	Ruth Nelson	Jean Stein
Linda & Arthur Carter	Sy Jacobs	Mark Nesselson, M.D.	Anne Meara & Jerry Stiller
Rachel Chanoff	Whitney Scott & Peter Jacobson	& Elliott Rosenblum	Susanna Styron & Darrell Larson
Glenda Chesshir	Macon R. & Michael B. Jessop	Cynthia Nixon	Daniel Swee
Ethan Coen & Trish Cooke	Amanda Johns	Steven O'Neill	Mariko Tada
Lietla Hesen-Cohen & Richard Cohn	Julia A. Johns	Kevin O'Rourke & Edith Thurber	Jay & Rachel Tarses
Thomas Cott	Andrea Johnson	Carol Ochs & Bruce MacVittie	Mary Lou Teel & Peter Freundlich
Margaret Crimmins	Traci Paige Johnson	Paul & Maria Onderdonk	Joan Vail & John Thorne
Colleen Croft & Louis Balducci	& Robert Mowen	Steven & Margot Peter	Tracy Thorne & Edmund Lewis
Stephen & Sandra Crudgington	Cherry Jones & Mary O'Connor	Elizabeth Peters	John & Katherine Turturro
Willem Dafeo & Liz Lecompte	Larry & Mary Jones	Bat-Sheva & Thomas Peters	Laura Valeroso & David Seidman
Arthur Dantchik	Maurice Kanbar	Ethan Phillips	Katrina vanden Heuvel
Peter & Judith Dawkins	Ronald Kastner	Susan Ochs Phillips	Wendy vanden Heuvel
Edward & Joanne DiRugieris	Susan Kaufman	Virginia Pike	& Brad Coley
Alex Draper & Lorraine Tobias	Mark Keoppen & Wendy Townsend	Oliver Platt	William & Melinda vanden Heuvel
Richard & Rebecca Dresser	John Kirtley	& Camilla Campbell Platt	John A. Vassallo
Christopher & Karen Eddowes	Seth & Beth Klarman	Richard Polatchek	Mary Pat Walsh
Mario Egozi	Joana & Jason Kliot	Jeremy Posner	Borah & Mildred Walton
David Eigenberg	Mary Kong	Dean & Leslie Potashner	Sally & Lenny Weiss
Ned Eisenberg	Judy Kuhn & David Schwab	Gigi Pritzker Pucker	Gregory Welch
Barbara Ettinger	Roger & Belle Kuhn	& Michael Pucker	Jane Bolster & Steve Wertimer
Barbara Ettinger & Sven Huseby	Michael A. Lane	Christopher Randolph	Donna & Walter Wick
Heidi Ettinger	Mark Lanow & Joanne Astrow	Peter & Helen Randolph	Jenny Wiener
Wendy Ettinger & Derek McLane	Allan & Nanette Larson	Anthony Ranieri	Michael & Zena Wiener
Adam Felber & Jeanne Simpson	Jill Larson	Paul Reale & Barbara McCrane	Matt Williams & Angelina Fiordellisi
Gerald Fernandez	Kate Lear & Jonathan LaPook	Willie Reale & Jenny Gersten	Jan Wilson & Saula Cutter
Peter Jay Fernandez	Mitchell Lemsky & Jane Bodle	Theresa Rebeck & Jess Lynn	Donald Windham
& Denise Burse	Robert Sean Leonard	Alysia Reiner & David Basche	Joanne Woodward & Paul Newman
Hannah Finn & John Wiltshire	Joshua Lewis	Jacquelyn Reingold	Anne & Charles Wright
Alexa Fogel	Mark Linn-Baker & Adrienne Lobel	Todd Richter & Donna Plummer	Jeffrey & Janine Yass
Tom Fontana & Sagan Lewis	Jessica Lissy	Herald & Linda Ritch	James & Mary Lin Yoshimura
Katherine Foster	John Bedford Lloyd	David & Anita Rogerson	Aylin Yuksek
David Frankel	& Anne Twomey	Robin Morse & Gus Rogerson	Virginia Zakian & Robert Sandberg

## THE 52ND STREET PROJECT PRESENTS



# JUST ASKIN': THE CURIOSITY PLAYS

## THE WINTER 2001 PLAYMAKING PLAYS

HB PLAYWRIGHT'S FOUNDATION

124 BANK ST.

FRIDAY, MAR. 23 AT 7:30 P.M.

SATURDAY, MAR. 24 AT 3:00 P.M. AND 7:30 P.M.

SUNDAY, MAR. 25 AT 3:00 P.M.



# JUST ASKIN'

THE CURIOSITY PLAYS

The Winter 2001  
Playmaking Plays  
HB Playwright's Foundation  
Mar. 23-25, 2001

**The 52nd Street Project Staff:**

Gus Rogerson, Artistic Director  
Carol Ochs, Executive Director  
Michael Bernard, Associate Artistic Director  
John Sheehy, Director of Development and Marketing  
George "X-Acto" Babiak, Production Manager  
Julie Feldman, Director of Education  
Megan Sandberg-Zakian, Volunteer Coordinator  
Chris Ceraso, Teen Dean  
Iris A. Brown, Graphic Designer  
Mayleen Cancel and Lorraine Zambrano, Receptionists  
Interns: Liz Bell, Jennifer Boring, Emily Crow, Kate Hancock



**Production Staff**

**Composer:** Rusty Magee  
**Set Designer:** Kevin Joseph Roach  
**Lighting Designer:** Greg MacPherson  
**Costume Designer:** Crystal Thompson  
**Sound Designer:** Jennifer Boring  
**Stage Manager:** Noël Dawkins  
**Slide Design Team:** Kevin Coffey, Kim Snow, Iwona Waluk, Monty Nicol, Richard Hicks, Vickie Clarke, Katherine Lumb

**Prop Design Team:** George Babiak, Jennifer Boring, Heather Carnduff, Jodi Cohen, Stacy Cohen, Emily Crow, Lucas Fleischer, Martin Gobbée, Kate Hancock, Cara Marcous, John Sheehy

**"Just Askin'" Illustrations:** Cara Marcous

**Furniture Crew:** Doug Lockwood, Johnathan "Big J" Roldan  
**Prop Crew:** Emily Crow, Jeni Saunders  
**Slide Projector Apparatus Manager:** Kate Hancock  
**Load-in and Light-hang Crew:** Mona Arriola, Jennifer Boring, Emily Crow, Elissa Errick, Tim Gallagher, Kate Hancock, Allison Kyle, Christopher Randolph, Chris Ryan, Tom Schall, John Sheehy, Matt Staniec, Vanessa Valdes, Becky White

**House Manager:** Karin Schall, Susan McGinniss

**Weekend-away Host:** Stephen and Cathy Graham

**Weekend-away chef:** Kimberly Diamond Mines



NATIONAL  
ENDOWMENT  
FOR THE ARTS

The Playmaking Program is made possible with public funds from the National Endowment for the Arts; The New York State Council on the Arts, a state agency; the Department of Youth and Community Development; and the New York City Department of Cultural Affairs. The 52nd Street Project is a member of Art/NY.

State of the Arts



NYSCA

## COOL STUFF ON SALE IN THE LOBBY!

The Fabulous Flyer Bar .....\$2.00 & \$1.50  
and featuring Shel Silverstein's "Fivey and Twoey" logo:  
Project T-shirts (short sleeve) .....\$12.00  
Project Tank Tops .....\$12.00  
Project Caps .....\$15.00  
Project Mugs .....\$5.00  
Project Pencil 3-pack (now in RED!) .....\$1.00

Thank you for coming to **JUST ASKIN'**! If you are not on our mailing list (or if your address has changed), please fill out this form and give it to us on your way out or mail it to the address below. We would also like to know if you are interested in becoming a volunteer. We need help in **all areas**, so be sure to fill out the entire form.

**PLEASE ADD ME TO YOUR MAILING LIST:**

3/01

NAME: \_\_\_\_\_

ADDRESS: \_\_\_\_\_

ZIP \_\_\_\_\_

HOME PHONE: \_\_\_\_\_

DAYTIME PHONE: \_\_\_\_\_

E-MAIL ADDRESS: \_\_\_\_\_

MY OCCUPATION: \_\_\_\_\_

MY HOBBIES: \_\_\_\_\_

**YES, I WOULD LIKE TO BE OF HELP. I CAN:**

- |   |   |  |
|---|---|--|
| <input type="checkbox"/> Help load in and out for shows | <input type="checkbox"/> Draw and/or paint  | <input type="checkbox"/> Help kids with homework |
| <input type="checkbox"/> Hang lights                    | <input type="checkbox"/> Help with mailings | <input type="checkbox"/> Teach kids a skill      |
| <input type="checkbox"/> Work on a backstage crew       | <input type="checkbox"/> Do office work     | <input type="checkbox"/> Be a chef at an event   |
| <input type="checkbox"/> Do graphic design              | <input type="checkbox"/> Design sound       | <input type="checkbox"/> Design and sew costumes |
| <input type="checkbox"/> Other (please specify) _____   |   |  |

**MY SCHEDULE IS:**

- Very flexible. I'm often available during weekdays.  
 Somewhat flexible. I can help on the occasional morning or afternoon during the week.  
 Not very flexible at all, but I've got some free time on evenings and weekends.

If you would like to mail this (and you're always welcome to enclose a tax-deductible contribution), you can send it to: **The 52nd Street Project**, 500 West 52nd St., New York, NY 10019. Or fax it to (212) 333-5598.

## Don't Miss Our Upcoming Shows!

HONORARY CO-CHAIRS GINA TORRES AND LAURENCE FISHBURNE INVITE YOU TO  
**SAVE THE STARDATE: MAY 7, 2001**

# 52001:



THE 52ND STREET PROJECT'S  
**SPACE BENEFIT**

**IN SPACE NO ONE CAN HEAR YOU SCREAM WITH LAUGHTER!**

For information or reservations call  
Commander John Sheehy at (212) 333-5252.

William Shakespeare's

# THE TEMPEST

Adapted by Chris Ceraso and  
the Project's Teen Ensemble

Directed by  
Michael Bernard



NEW YORK  
PERFORMANCE:  
June 29th

LONDON, ENGLAND  
PERFORMANCE:  
July 4th

IPSWICH, ENGLAND  
PERFORMANCE:  
July 6th

The 52nd Street Project is a non-profit organization that brings inner-city children from the Hell's Kitchen neighborhood together with professional theater artists to create original theater. **Just Askin'!** is a production of our Playmaking program. Young people participate in an eight-week playwriting course taught by Michael Bernard and adapted for the Project by Daniel Judah Sklar from his book *Playmaking: Children Writing and Performing Their Own Plays*. At the end of the course, each child is given two actors, a theme, and a dramaturg/director who guides him or her through the writing of a play during a weekend retreat in the country. Tonight's performance is the end result.

### The 52nd Street Project Board of Directors

Ben Barenholtz	Patricia M. Murphy, Esq.
Lisa Benavides	Carol Ochs
Rachel Chanoff	Willie Reale
Heidi Ettinger	Gus Rogerson
Wendy Ettinger, <i>chair emeritus</i>	José Soto, Jr., <i>alumni boardmember</i>
Louis P. Friedman	Pamala Tyson
Stephen Graham	Laura Valeroso
Larry Jones	Wendy vanden Heuvel
James McDaniel	Jenny Wiener
Frances McDormand, <i>chair</i>	

### Special Thanks

We're grateful to Stephen and Cathy Graham for graciously allowing us to bring the chaos of a Playmaking weekend to their lovely home in Kent, Connecticut. Thanks also go to Sam and Lynn Waterston, and Dave and Susie Ott for providing overnight accommodations. A thousand thanks to Wendy vanden Heuvel for making a thousand phone calls to find us places to stay. Finally, Billy Carden, David and all the hard-working interns at HB Playwright's Foundation earn our thanks for making us feel so welcome on Bank St.



Help build the Clubhouse Library! Buy us a book or two from **Amazon.com** by logging on to our on-line "wish list." Scroll down the right side of their home page and click on WISHLIST, then type "project52@aol.com" into the email search field. Then just click away to stock our stacks!

## JUST ASKIN': THE CURIOSITY PLAYS— ACT I

All original music composed by Rusty Magee

### Friendship

by Anastasia Kehr, age 11. Dramaturg/Director: Liz Tuccillo.

Billiard .....Josh Lewis  
Summer .....Maria Tucci

### Gonlap Disagrees

by Wonkezeh Newenle, age 12. Dramaturg/Director: Maury Schott.

Myta .....Reed Birney  
Gonlap .....Arthur French  
Pota .....Myra Lucretia Taylor  
Contestants .....Johnathan Roldan, John Sheehy  
Referee .....Teagle Bougere

*“To Keep the Family Together”* lyrics by Wonkezeh Newenle

### I Want, You Want

by Katherine Acosta, age 10. Dramaturg/Director: Liliana Amador.

Taina .....Tanya Gingerich  
Jessica .....Keira Naughton  
Clerk .....Doug Lockwood  
Operator .....Jeni Saunders  
Police Officer .....Johnathan Roldan

### The Drain

by Edwin Toro, age 12. Dramaturg/Director: Michael Dolan.

Mike .....Teagle Bougere  
Melissa .....Marissa Copeland  
Announcer .....Doug Lockwood

### Single Beauties

by Suzette Santana, age 10. Dramaturg/Director: Peter Jay Fernandez.

Nayomi .....Edie Falco  
Britney .....Lisa Leguillou  
Announcer .....Doug Lockwood

*“Single Beauties”* lyrics by Suzette Santana

☞ **Intermission!** ☞

## ACT II

### The Woodsman and The Tree

by Barry Myers, age 10. Dramaturg/Director: Gus Rogerson.

Spikey Life .....Anthony Barrile  
Ring .....Robert Colston

### If You Could Understand Me

by Evelyn "Nicky" Rosario, age 10. Directed by Ashby Semple.

Elvea .....Nedra Gallegos  
Alabama .....Jennifer Ostrega  
James .....Johnathan Roldan  
Dr. Cutwig .....John Sheehy  
Crystal .....Emily Crow

*“If You Could Understand Me”* lyrics by Evelyn “Nicky” Rosario

### The Diseased Monkey

by Alex Kehr, age 10. Dramaturg: Michael Bernard  
Director: Jessica Bauman.

Koo Koo .....James Naughton  
Spot .....Frank Wood

### Amanda and J.J.

by Ariana Casablanca, age 11. Dramaturg/Director: Saudia Young.

Amanda .....Myra Lucretia Taylor  
J.J. ....Godfrey L. Simmons, Jr.  
David .....Joe White

*“Amanda’s Song”* lyrics by Ariana Casablanca

### Paint Brush

by Joshua Joya, age 11. Dramaturg/Director: Joe White.

Winston .....Arthur French  
Roger .....Kevin Geer  
Anna .....Stephanie Bast

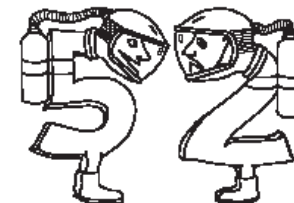

Jenny Wiener, Mosaic Entertainment and the Board of Directors of The 52nd Street Project present

# 52001: A SPACE BENEFIT



**BOARD CHAIR**

Frances McDormand

**ARTISTIC DIRECTOR**

Gus Rogerson

**EXECUTIVE DIRECTOR**

Carol Ochs

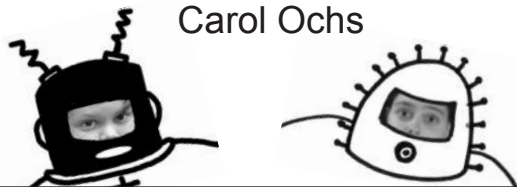

## Honorary Chairs

Laurence Fishburne and Gina Torres

## Co-Chairs

Lisa Benavides  
Becky Browder  
Louis P. Friedman  
Patrice Friedman

Karin Schall  
Laura Valeroso  
Mary Pat Walsh  
Jenny Wiener

## The Board of Directors

Ben Barenholtz  
Lisa Benavides  
Rachel Chanoff  
Heidi Ettinger  
Wendy Ettinger,  
*chair emeritus*  
Louis P. Friedman  
Stephen Graham  
Larry Jones  
James McDaniel  
Frances McDormand,  
*chair*

Patricia M. Murphy, Esq.  
Carol Ochs  
Willie Reale,  
*founder*  
Gus Rogerson  
Jose Soto, Jr.,  
*alumni boardmember*  
Pamala Tyson  
Laura Valeroso  
Wendy vanden Heuvel  
Jenny Wiener



The 52nd Street Project  
gratefully acknowledges...

Au'Some Candies Inc.  
Big Apple Lights  
Iris A. Brown  
Capital Printing/Ron Kastner  
The Coleman Company,  
*A subsidiary of the Sunbeam corporation*  
Entertainment Weekly  
The Gap  
Hudson Scenic Studios  
Noggin  
The Printing Store  
Scholastic, Inc.  
Seagram's Chateau & Estate Wines Co.  
Sesame Workshop  
Wendy Stulberg  
John A. Vassilaros & Sons  
Watkins Incorporated  
*Healthier Living Since 1868*



## The Cast

General Leigh Speaking . . . . . Tiffany Butler  
Major Spacecase . . . . . Frances McDormand  
Borax . . . . . Oliver Platt  
Chore Boy . . . . . Michael Feliciano  
Lestoil . . . . . Maria Tucci  
Spongemop . . . . . Jeremy Butler  
The Bearer . . . . . Lewis Black  
The Assistant . . . . . Octavia Rodriguez

Plus a special vocal appearance by  
Dan Castellaneta

## THE SONGS

"Funny Stuff from Outer Space,"  
and "An Important Message from Borax"



## DIRECTED BY

Jonathan Bernstein

## CREATIVE CONSULTANT

Becky Browder

## MUSIC COMPOSED AND PERFORMED BY

Rusty Magee

With additional musical direction by Ginny Pike

## LYRES BY

Willie Reale

## BOOK BY

Michael Bernard, Willie Reale, & John Sheehy

## SET DESIGN

Kevin Joseph Roach

## LIGHTING DESIGN

Greg MacPherson

## COSTUME DESIGN

Crystal Thompson

## SOUND DESIGN

Tom Morse

## STAGE MANAGER

Hank Meiman

## PROP AND SET DESIGN TEAM

George Babiak, Jen Boring, Heather Carduff,  
Emily Crow, Kate Hancock, Cara Marcous,  
Rick Meese, Alice Moss, Kevin Roach

## SUPERNOVAE

Arthur Dantchik  
Heidi Ettinger  
Wendy Ettinger & Derek McLane  
Patrice & Louis Friedman  
Cathy & Stephen Graham  
Jenny Wiener, Mosaic Entertainment  
Jeffrey Yass

## RED GIANT TABLES

Tom Cruise  
The Dawkins Family Foundation  
Angelina Fiordellisi & Matt Williams  
Fred Nelson, Entertainment Weekly  
The New World Foundation  
Jeremy M. Posner

## INTERPLANETARY TABLES

Blaise R. Box/Staging & Design, Inc.  
Rachel Chanoff  
Comedy Central  
Robert Goldberg, Yorke Construction  
Jane Perlmutter & Greg MacPherson  
Maury Schott  
Laura Valeroso & David Seidman  
Alexandra & John Vassilaros

## FIRST OFFICERS

Lisa Finstrom & Tim Sanford  
Terry Fitzpatrick & Stephen Perepeluk  
Alexa L. Fogel  
Frank Frattaroli  
Michael Greif & Jonathan Fried  
Jane & Jonathan Heine  
Julia Johns  
Maurice Kanbar  
Dana Kellin & Paul McCrane  
Kate Lear & Jonathan LaPook  
John S. Lyons  
Jesse L. Martin  
Audrey & Danny Meyer  
Janet Momjian & Steve Olsen  
Jane Musky & Tony Goldwyn  
Anita & David Rogerson  
Elaine & Aaron Shapiro, Shapiro & Lobel LLP  
Jonathan Sheffer  
Brian Swardstrom  
Drs. Mildred & B.W. Walton  
Anita Waxman  
Joanne Woodward & Paul Newman  
Mary Lin & Jim Yoshimura



## COSMNAUTS

Ben Barenholtz  
Lisa Benavides & Tim Nelson  
Elizabeth & Alexander Bernstein  
André Bishop & Peter Manning  
Susan Bruce & Peter Hedges  
Kate Burton & Michael Ritchie  
Colleen Carroll & Mitchell Semel  
Glenda Chesshir  
Cynthia & Jerome Congress  
Maddie Corman & Jace Alexander  
Barbara Ettinger & Sven Huseby  
Victor Garber  
Jilian Cahan Gersten  
Lisa J. Gugenheim  
Cherry Jones & Mary O'Connor  
Linda LeRoy Janklow  
Traci Paige Johnson & Bob Mowen  
George Kaiser Family Foundation

Judy Kuhn & David Schwab  
Susan & Richard Lobel  
Margo Lion  
Adrienne Lobel & Mark Linn-Baker  
Ali Marsh & Fred Weller  
Dr. Mark Nesselson & Elliot Rosenblum  
Shevi & Tom Peters  
Sue Ochs Phillips  
Leslie & Dean Potashner  
Christopher Randolph  
Theresa Rebeck & Jess Lynn  
Daryl Roth  
Steve Sabba  
Laura Sametz  
Lynn Street & Donald Margulies  
Susanna Styron & Darrell Larson  
Daniel Swee

## ROCKETMEN AND ROCKETWOMEN

Beth & Ray Abbott  
Amy Aquino & Drew McCoy  
June Ballinger & Michael Goldstein  
Talia Balsam & John Slattery  
Benny Bartley  
Stephanie Berger & Paul King  
Stephen Bernstein  
Dan Berrett  
Colleen Berry  
Vicky Bijur & Ed Levine  
Tessa Blake & Neal Lerner  
Audrey Bloch  
Jane Bodle & Mitchell Lemsky  
Jane Bolster & Steve Wertimer  
Kathy Briggs  
Becky Browder & Ted Neustadt  
Denise Burse & Peter Jay Fernandez  
Lea Carpenter  
Isabel Charles  
Kathleen Clark & Richard Frankel  
David Copeland  
Margaret Crimmins & Vytas Nagisetty  
Anna Crouse  
Cathy & George Crow  
Saula Cutter & Jan Wilson  
Nadia Dajani  
Rebecca & Richard Dresser  
Dianne Dreyer  
Moirra Driscoll & David Pence  
Anthony Dub  
C.C. Dyer  
Karen & Christopher Eddowes  
Alon Egozi  
Mario Egozi  
Ned Eisenberg  
Billy Finnegan  
Ellie Freudenheim & Daniel Wiener  
Geraldine Frey  
Doreen Frumkin  
Rose Gasner & Larry Chertoff  
Kevin Geer  
Jenny Gersten & Willie Reale  
Ileen Getz & Mark Grinnell

Kilty & Lloyd Gilmour  
Bryan Gmitter  
Judy Goldman & Michael Pillinger  
Wendy Goldman  
Robyn Goodman  
Connie Grappo & Lee Wilkof  
Mary Grieco  
Flavia & Edward Grimm  
Amanda Guinzburg  
Marianne Hagan  
Evan Handler  
Elizabeth & David Herdrich  
Lieta Hesen-Cohn & Richard Cohn  
John Benjamin Hickey  
Katherine Homans & Patterson Sims  
Caroline Hon  
Michelle Hurst  
Amy Introcaso-Davis  
Virginia & Richard Irwin  
Dana Ivey  
Latanya & Samuel L. Jackson Foundation  
Joanne Jacobson  
Macon & Michael Jessop  
Amanda Johns  
Julia Judge  
Marcella & Max Kahn  
Jay Kane  
Eric Karpeles & Mike Sell  
Mark Keoppen  
Al Klingenstein  
Mary Kong  
Christine Kromer  
Renée Landau  
Jill Larson  
Howard Leifman  
Liza Lerner  
Jane Lew  
Joshua Lewis  
Line Lillevik & James Waterston  
Jessica Lissy  
Chip Loutrel  
Brigid McCarthy  
Betsy McClelland & Chia Messina

Edelen McWilliams  
Anne Meara & Jerry Stiller  
Janis & Alan Menken  
Dean Michaels  
Beth & Ross Moore  
Bob Morris  
Meg Mortimer  
Suzen Murakoshi  
Patricia Murphy & Adam Spilka  
Beth & Tim Murtha  
Eileen Nash  
Heather Nash  
Rona & Randy Nelson  
Margaret Norden & Joseph Gazdak  
Ellen Novack  
Ricarda O'Conner  
Steven O'Neill  
Jacki Ochs & Jan Kroeze  
Kimberly Ochs  
Maria & Paul Onderdonk  
Jeff Otis  
Juli Pari-Frankel & Eric Frankel  
Paris Chocolate  
Stacie & Alyson Passon Shapero  
Jodi Peikoff  
Margot & Steve Peters  
Lindsay Porter  
Michael Potts  
Roger Raines  
Anthony Rapp  
Lucy Retan & Tom Sapien  
Loree Rodkin  
Janice & Daniel Rous  
Mary Anne Rubacky  
Richard Rubinstein  
Josh Safran  
Zeborah Schachtel  
Stacey Schaffer & Eric Schwartz

Karin & Thomas Schall  
Beth Schneider & Steve McFarland  
Whitney Scott & Peter Jacobson  
Stefan Selig  
Robert Shaffron & John Steber  
Sylvia Shepard & Willy Holtzman  
Connie Shulman & Reed Birney  
Meg Simon  
Landon Slane  
Lois Smith  
Abigail Rose Solomon  
Ivy & David Solowiejczyk  
Dorothy Spears & Vance Brown  
Frank Sposato  
Don Summa  
Mary Lou Teel & Peter Freundlich  
Edith Thurber & Kevin O'Rourke  
Anne Torsiglieri  
Patricia Triana  
Karen Trott & Peter Herdrich  
Maria Tucci & Robert Gottlieb  
Liz Tuccillo  
Christine Vachon  
Joyce Van Patten  
Cynthia Vance  
John Vassallo  
Joanna Vicente & Jason Kliot  
William Voelkel  
Jon Patrick Walker  
Mary Pat Walsh  
Carol J. Whitesides  
Elizabeth Williams & Joseph Forte  
Hannah & John Wiltshire  
Sarah Winkler & Simon Leopold  
Kurt Wottan  
Joey Xanders  
Vincent Yen  
Yildiz Yuksek & Richard Blackstone

List current as of 5/2/01



## THE 52ND STREET PROJECT STAFF

Gus Rogerson, Artistic Director  
Carol Ochs, Executive Director  
Michael Bernard, Associate Artistic Director  
John Sheehy, Director of Development and Marketing  
George Babiak, Production Manager and Helmsman  
Julie Feldman-Abe, Director of Education  
Megan Sandberg-Zakian, Volunteer Coordinator  
Liz Bell, Jennifer Boring, Emily Crow, Kate Hancock; Interns

## BENEFIT VOLUNTEERS

Heather Carnduff-Gobbée, Betsy Foldes, Rocio Galarza,  
Eris Migliorini, Doug Nervik, Jenny Peek

## SPECIAL THANKS

Mona Arriola, Jenny Gersten, Bryan Gmitter, Allison Kyle,  
Barbara McCrane, Christopher Randolph, Laura Sametz,  
Kim Sherman, Vanessa Valdes, Elizabeth Williams, Dan Wojner



Gus Rogerson, Artistic Director

Carol Ochs, Executive Director

The 52nd Street Project Presents



The 52nd Street Project

The 52nd Street Project is dedicated to the creation and production of new plays for, and often by, kids between the ages of ten and eighteen who reside in the Hell's Kitchen neighborhood in New York City. The Project does this through a unique mentoring program that matches kids with professional (and volunteer!) theater artists.

The Project is about making children proud of themselves. The Project is not about teaching children to act, although they will learn to. It is not about teaching them to write plays, although they will learn that as well. What it is about is giving a kid an experience of success. It is about giving a kid an opportunity to prove that he or she has something of value to offer, something that comes from within that he or she alone possesses, something that cannot be taken away.

The Project's Teen Ensemble is the final step in the kids' training: a two-year acting class that culminates in the production of a full-length play by William Shakespeare, the very one you are seeing tonight. We are very grateful to our gracious British hosts for enabling this tour.

*The following foundations and government agencies have generously supported the Teen Program through their contributions:*

**City of New York Department of Cultural Affairs  
Dammann Foundation  
Department of Youth and Community Development  
National Endowment for the Arts  
New York State Council on the Arts  
The Surdna Foundation**

# THE TEMPEST

By William Shakespeare

The 2001 British/American Tour

Directed by Greg Allen

Adapted by Chris Ceraso and  
The 52nd Street Project  
Teen Ensemble

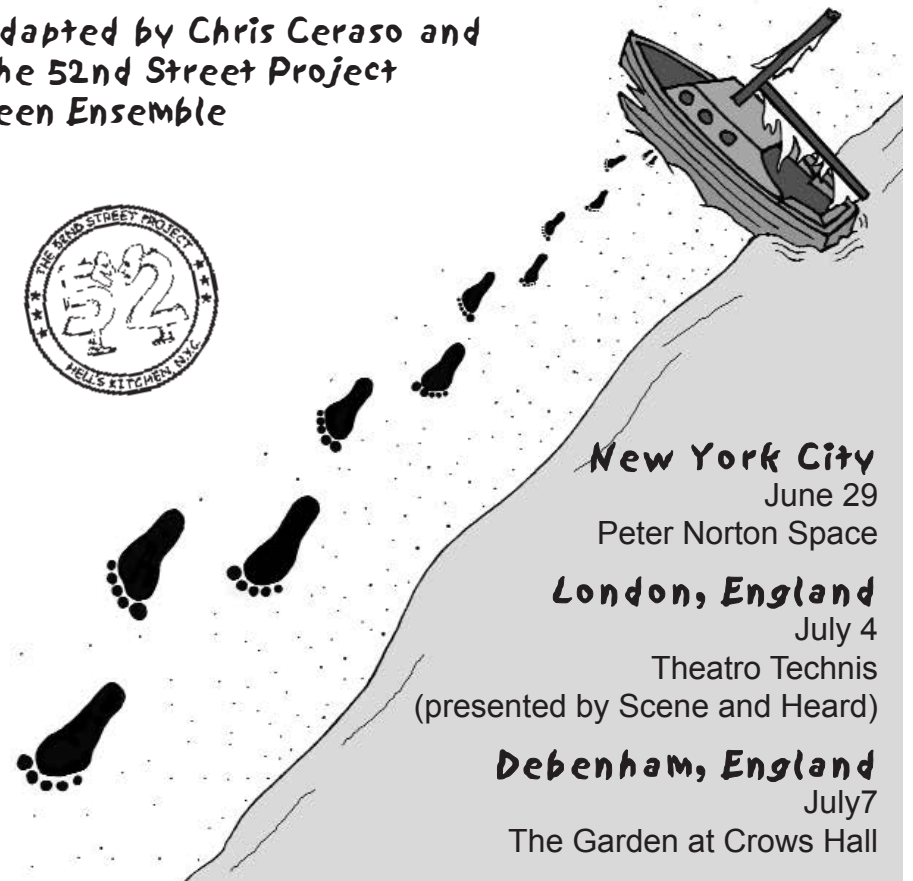

**New York City**

June 29

Peter Norton Space

**London, England**

July 4

Theatro Technis

(presented by Scene and Heard)

**Debenham, England**

July 7

The Garden at Crows Hall

## The Story of The Tempest

Prospero, a sorcerer and the rightful Duke of Milan, dwells on an enchanted isle with his daughter, Miranda. Twelve years earlier, the duke's sister, Antonia, and the King of Naples, Alonso, conspired to usurp Prospero's throne. Prospero and Miranda were set adrift in a boat, and they eventually found themselves marooned on the island. Prospero is served on his island by Ariel, a spirit whom he freed from a tree with magic, and Caliban, son of the witch Sycorax. When magic reveals that a ship bearing his old enemies is sailing near the island, Prospero summons a storm to wreck the ship. The survivors make it to shore in scattered groups. Among these is Ferdinand, the son of Alonso. He is lured to Prospero's abode by the singing of Ariel; there he meets Miranda, who is enthralled with the young prince.

Meanwhile, Antonia, Alonso, Sebastienne, and Gonzala wander the island in search of Ferdinand. Antonia now plots with Sebastienne to murder Alonso, but this plot is thwarted by Ariel. Elsewhere on the island, Stephano and Trincula encounter Caliban. After sharing a few drinks, Caliban tries to enlist the two in a plot to kill Prospero and rule the island himself. He even promises Miranda to Stephano. Ariel, however, reports all these goings-on to Prospero. In the meantime, Miranda and Ferdinand pledge their troth to each other.

Prospero isn't finished with his sport of Antonia and Alonso, either. He sends Ariel in the guise of a harpy to hound them for their crimes against him. Later, at a masque to celebrate the upcoming marriage of Miranda and Ferdinand, Prospero remembers Caliban's plot and abruptly calls the revels to a halt. He sends Ariel to punish Caliban, Trincula, and Stephano; the spirit does so by first luring them with some fancy clothes, then setting other island spirits upon them in the shape of hunting dogs that chase them around the island.

Finally, Prospero confronts his sister and Alonso, revealing his true identity as the rightful Duke of Milan. He demands that Antonia restore his throne; he also rebukes Sebastienne for plotting against her own brother. To Alonso, he reveals Ferdinand alive and well, playing a game with Miranda. As a final act, Prospero abandons his magic and releases Ariel and Caliban from their servitude. From Ariel, Prospero asks for one last boon: calm seas and favorable winds for their trip back to Naples.

*-adapted from J.M. Pressley, The Shakespeare Resource Center*

## The Cast

- Alonso, King of Naples .....Chris Ceraso
- Sebastienne, his sister .....Tessa John-Connor
- Prospero, Duke of Milan .....Larry Nathanson
- Antonia, his sister, Duchess of Milan .....Deshana Hamid
- Ferdinand, son to the King of Naples .....Alex Metzler
- Gonzala, an honest Counsellor .....Michaela Murphy
- Caliban, a savage and deformed Slave ...Thomas Santoni
- Trincula, a Jester .....Mary Vamvoukakis
- Stephano, a Cook .....Ahmed Attia
- Miranda, daughter to Prospero .....Judith Agosto
- Ariel, an airy spirit .....Sahara Walsh
- Boatswain .....Gus Rogerson
- Mariners .....Megan Sandberg-Zakian,  
Greg Allen, George Babiak
- Nymphs and other spirits .....The Company

Stage Manager: George Babiak  
Costume Design: Sarah Iams  
Choreography: Jeanne Simpson

For their help on the **New York** show, The 52nd Street Project would like to thank Michael Bernard, Cecilia Arana, Roz Coleman, Alex Draper, Catherine Mueller, Anne Torsilieri, Abigail Lopez, Susan McGinnis, Becky White, Jonathan Babicka, Pam Traynor, Paul Olmer, George Cortez, and The Signature Theatre. In **London**, we're grateful to Kate Coleman, Sophie Boyack and Scene and Heard, Ben Moor, Althea Stewart, Rachel Flint, Selina Boyack, and Vanessa Kastner. Finally, in **Debenham**, we are indebted to Oliver and Eleonora Knowland and Crows Hall, Mrs. Lennie Knowland, and John and Ann Knowland.

The 52nd Street Project gratefully acknowledges the support of the following foundations and corporations: Barker Welfare Foundation, The Bamsley Foundation, Blythmore Corporation, Capital Research Company, Carnegie Corporation of New York, Comedy Central, Consolidated Edison, The Dammann Fund, Deutsche Bank of Americas Foundation, The Dramatists Guild Fund, Eleanor, Dramatists Play Service, Adam & Mel Dubin Foundation, Doris Duke Charitable Foundation, The Educational Foundation of America, Entertainment Weekly, Ford Foundation, The Fan Fox & Leslie R. Samuels Foundation, The Horace W. Goldsmith Foundation, The Hennessy Foundation, Hudson Soenic Studio, Betty E. & George B. Kaiser Foundation, Rita J. and Stanley H. Kaplan Foundation, Lloyds TSB Bank plc, James A. Macdonald Foundation, Ann M. Martin Foundation, The Andrew W. Mellon Foundation, Helen Merrill, Ltd., J.P. Morgan Charitable Trust, The William Morris Agency, Mosaic Entertainment, The New World Foundation, The New York Times Company Foundation., Newman's Own, Paramount Pictures, Laura Pels Foundation, Staging and Design, Inc., Harold & Mimi Steinberg Charitable Trust, The Surdna Foundation, Susquehanna, Theater Communications Group, John A. Vassilaros & Sons, Inc., The Vervane Foundation, West Bank Cafe, Yorke Construction Corporation. In addition the following individuals made gifts of over \$150 this year (list is current as of 7/25/01)

Anonymous	Terry Fitzpatrick & Liliانا Amador-Martí & Frank Martí	James Waterston & Line Lillevik	Donald Rothschild & Lottchen Shivers
Mark Lanow & Joanne Astrow	Alexa Fogel	Stephen Perepeluk	Kenneth Rothstein
Mary Bacon & Andrew Leynse	Katherine Foster	Jessica Lissy	Alexander Roy
June Ballinger & Michael Goldstein	David Frankel	Adrienne Lobel & Mark Linn Baker	Steve Sabba
Talia Balsam & John Slattery	Eric & Juli Frankel	Richard & Susan Lobel	Laura Sametz
Ben Barenholtz	Naomi Freundlich & Charles Miles	Charles Loutrell	Tim & Lisa Sanford
Benny Bartley	Louis & Patrice Friedman	Chris & Sally Lutz	Karin & Tom Schall
Jessica Bauman	Hank Gallo	John Lyons	Beth Schneider
Laurie Becker & Rick Sweren	Victor Garber	Marsue & Peter MacNicol	Maurly Schott
Gregory Bello	Beth Gardiner	Paul & Lauren Mandell	Marc Segan
Lisa Benavides & Tim Nelson	Rose Gasner & Larry Chertoff	Brian & Marsha Mannain	Stefan Selig
Barry & Myrna Bernard	Joseph & Margaret Gazdak	Elizabeth Manne	Jeffrey Soller & Joshua Lehr
Brian Swardstrom & Bonnie Bernstein	Hillel & Celia Gershenson	Peter Manning & André Bishop	Alyson Shapero
Alexander & Elizabeth Bernstein	Alexandra Gersten & John A. Vassilaros	Ali Marsh	Aaron & Elaine Shapiro
Stephen Bernstein	Willie Reale & Jenny Gersten	Jesse L. Martin	Jonathan Sheffer
Vicky Bijur & Ed Levine	Jilian Cahan Gersten	Dave & Alicia Matthews	William Holtzman & S. Sylvia Shepard
Jeanette & Samuel Black	Ileen Getz & Mark Grinnell	Drew McCoy & Amy Aquino	Reed Birney & Connie Shulman
Lewis Black	Nancy Giles	Paul Reale & Barbara McCrane	Meg Simon
Tessa Blake	Lloyd & Kilty Gilmour	Timothy Murtha & Elizabeth McDermott	Adam Felber & Jeanne Simpson
Mitchell Lemsky & Jane Bodle	Bob Glennon	Fran McDormand & Joel Coen	Phillip K. & Gloria W. Smith
Jane Bolster & Steve Wertimer	Judy Goldman & Michael Pilling	Anne Meara & Jerry Stiller	Abigail Rose Solomon
Buzz Bovshow	Stephen & Cathy Graham	Alan & Janis Menken	Dr. David Solowiejczyk
Alan Braverman	Connie Grappo & Lee Wilkof	Chia Messina	John Steber & Robert Shaffron
Kathy Briggs	Michael Greif & Jonathan Fried	Audrey & Danny Meyer	James Neuberger & Helen Stambler
Becky Browder & Ted Neustadt	Mary Grieco	Dean Michaels	Jean Stein
Susan Bruce & Peter Hedges	Emily Grishman & Susan Sampliner	Ross & Beth Moore	Ben & Christine Stiller
Peter Jay Fernandez & Denise Burse	Lisa Gugenheim	John Morning	Abbot B. Stranahan
Kate Burton & Michael Ritchie	Evan Handler	Robin Morse & Gus Rogerson	Donald Margulies & Lynn Street
Cora Cahan & Bernard Gersten	Jane & Jonathan Heine	Patricia M. Murphy, Esq. & Adam Spilka	Susanna Styron & Darrell Larson
Mitchell Semel & Colleen Carroll	Amy Henkels	Tony Goldwyn & Jane Musky	Daniel Swee
Linda & Arthur Carter	David Herdrich & Elizabeth Palmer Herdrich	Geoffrey Nauffts	Mariko Tada
Rachel Chanoff	Peter Herdrich & Karen Trott	Randy & Rona Nelson	Jay & Rachel Tarses
Ellen Chenoweth	Lieta Hesen-Cohen & Richard Cohn	Rurth Nelson	Mary Lou Teel & Peter Freundlich
Glenda Chesshir	Caroline Hon	Mark Nesselson, M.D. & Elliott Rosenblum	Tracy Thorne & Edmund Lewis
Marissa & Travis Chibas	Michelle Hurst	Cynthia Nixon	Kevin O'Rourke & Edith Thurber
Richard Frankel & Kathleen Clark	Virginia & Richard Irwin	Steven O'Neill	Gina Torres
Jerome Cohen Congress	Sy Jacobs	Carol Ochs & Bruce MacVittie	Anne Torsiglieri
Jace Alexander & Maddie Corman	Whitney Scott & Peter Jacobson	Jacki Ochs & Jan Kroeze	Joan Vail & John Thorne
Max Mayer & Catherine Corpeny	Linda Janklow	Paul & Maria Onderdonk	Laura Valeroso & David Seidman
Margaret Crimmins	Macon R. & Michael B. Jessop	Greg MacPherson & Jane Perlmutter	Robert Abrams & Cynthia Vance
George & Cathy Crow	Tom Slaughter & Marthe Jocelyn	Steven & Margot Peter	Wendy vanden Heuvel & Brad Coley
Cameron Crowe	Amanda Johns	Bat-Sheva & Thomas Peters	John A. Vassallo
Stephen & Sandra Crudgington	Julia A. Johns	Peter & Ana Rosa Phillips	Borah & Mildred Walton
Tom Cruise	Andrea Johnson	Susan Ochs Phillips	Anita Waxman
Arthur Dantchik	Traci Paige Johnson & Robert Mowen	Oliver Platt & Camilla Campbell Platt	Sally & Lenny Weiss
Peter and Judith Dawkins	Cherry Jones & Mary O'Connor	Richard Polatchek	Daniel Wiener
Edward & Joanne DiRugeri	Larry & Mary Jones	Jeremy Posner	Jenny Wiener
Jon Divis & Gene Reilly	Maurice Kanbar	Dean & Leslie Potashner	Michael & Zena Wiener
Richard & Rebecca Dresser	Lisa A. Kauffman	Gigi Pritzker Pucker & Michael Pucker	Elizabeth Williams & Joseph Forte
Christopher & Karen Eddowes	Paul McCrane & Dana Kellin	Christopher Randolph	Jan Wilson & Saula Cutter
Mario Egozi	Seth & Beth Klarman	Peter & Helen Randolph	Donald Windham
David Eigenberg	Joana & Jason Kliot	Alysia Reiner & David Basche	Sarah Winkler & Simon Leopold
Ned Eisenberg	Mary Kong	Lucy E. Retan	John Woo
Sophia & Gordon Elliott	Judy Kuhn & David Schwab	Kate & Chris Robinson	Joanne Woodward & Paul Newman
Barbara Ettinger	Allan & Nanette Larson	Loree Rodkin	Jeffrey & Janine Yass
Barbara Ettinger & Sven Huseby	Kate Lear & Jonathan LaPook	David & Anita Rogerson	James & Mary Lin Yoshimura
Heidi Ettinger	Robert Sean Leonard	Clifford & Betsy Ross	Richard Blackstone & Yldez Yuksek
Wendy Ettinger & Derek McLane	Becky & Steven Lewis	Daryl Roth	Virginia Zakian & Robert Sandberg
Hannah Finn & John Wiltshire			Stuart Zicherman
Billy Finnegan			
Matt Williams & Angelina Fiordellisi			

The 52nd Street Project presents  
The 2001 Harold and Mimi Steinberg Charitable Trust One-on-Ones

# PUNS IN THE OVEN



JULY 26-29, 2001

## THE ENSEMBLE STUDIO THEATRE

549 WEST 52ND ST., NEW YORK CITY



# PUNS IN THE OVEN

## PLAYS ON WORDS

The 2001 Block Island  
One-on-Ones  
July 26-29  
The Ensemble Studio Theatre

### The 52nd Street Project Staff:

Gus Rogerson, Artistic Director  
Carol Ochs, Executive Director  
Michael Bernard, Associate Artistic Director  
John Sheehy, Director of Development and Marketing  
George "X-Acto" Babiak, Production Manager  
Julie Feldman, Director of Education  
Megan Sandberg-Zakian, Volunteer Coordinator  
Chris Ceraso, Teen Dean  
Liz Bell, Education Assistant  
Iris A. Brown, Graphic Designer  
Mayleen Cancel and Lorraine Zambrano, Receptionists  
Interns: Jonathan Babicka, Sarah Petersiel

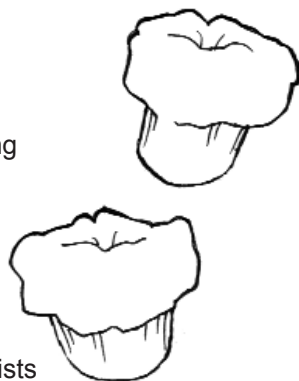

### Production Staff

**Composer:** Kim D. Sherman  
**Set Designer:** Kevin Joseph Roach  
**Lighting Designer:** Greg MacPherson  
**Costume Designer:** Erin Billings  
**Sound Designer:** Vanessa Valdes  
**Stage Manager:** Allison Kyle  
**Slide Design Team:**  
Kevin Coffey, Kim Snow, Iwona  
Waluk, Monty Nicol, Richard Hicks,  
Vickie Clarke, Katherine Lumb  
**Prop Design Team:**  
Ceci Arana, George Babiak, Benny  
Bartley, Eileen Hecker, Alex and Ani  
Kehr, Scott and Stacey Linden, Mona  
Lipson, Kevin Roach, Abigail  
Ransmeier, Alison Rogers, John  
Sheehy, Frankie Ventura, Maja  
Wampuszyc

**"Puns" Illustration:** Mike Sell  
**Furniture Crew:**  
Jonathan Babicka, Noel Polanco  
**Prop Crew:**  
Sarah Petersiel, Mayleen Cancel,  
Mary Vamvoukakis,  
Johnathan "Big J" Roldan  
**Load-in and Light-hang Crew:**  
Mona Arriola, Jonathan Babicka, Tim  
Gallagher, Nedra Gallegos, Allison  
Kyle, Rick Meese, Sarah Petersiel,  
Tom Schall  
**House Managers:**  
Karin Schall, Liz Flahive  
**Chefs:**  
Pat McQuade and Martha Velie-Gass  
**Teen Counselor:**  
Mayleen Cancel



The One-on-One Program is made possible with public funds from the National Endowment for the Arts; The New York State Council on the Arts, a state agency; the Department of Youth and Community Development; and the New York City Department of Cultural Affairs Cultural Challenge Program. The 52nd Street Project is a member of Art/NY and a participant in the New Generations Program, funded by Doris Duke Charitable Foundation/The Andrew W. Mellon Foundation and administered by Theatre Communications Group, the national organization for the American Theater.



## COOL STUFF ON SALE IN THE LOBBY!

The Fabulous Flyer Bar .....\$2.00 & \$1.50  
and featuring Shel Silverstein's "Fivey and Twoey" logo:  
Project T-shirts (NEW design) .....\$12.00  
Project Tank Tops .....\$12.00  
Project Caps (NEW design) .....\$15.00  
Project Mugs .....\$5.00  
Project Pencil 3-pack (now in RED!) .....\$1.00

Thank you for coming to **PUNS IN THE OVEN!** If you are not on our mailing list (or if your address has changed), please fill out this form and give it to us on your way out or mail it to the address below. We would also like to know if you are interested in becoming a volunteer. We need help in **all areas**, so be sure to fill out the entire form.

### PLEASE ADD ME TO YOUR MAILING LIST:

7/01

NAME: \_\_\_\_\_

ADDRESS: \_\_\_\_\_

\_\_\_\_\_ ZIP \_\_\_\_\_

HOME PHONE: \_\_\_\_\_

DAYTIME PHONE: \_\_\_\_\_

E-MAIL ADDRESS: \_\_\_\_\_

MY OCCUPATION: \_\_\_\_\_

MY HOBBIES: \_\_\_\_\_

### YES, I WOULD LIKE TO BE OF HELP. I CAN:

- |   |   |  |
|---|---|--|
| <input type="checkbox"/> Help load in and out for shows | <input type="checkbox"/> Draw and/or paint  | <input type="checkbox"/> Help kids with homework |
| <input type="checkbox"/> Hang lights                    | <input type="checkbox"/> Help with mailings | <input type="checkbox"/> Teach kids a skill      |
| <input type="checkbox"/> Work on a backstage crew       | <input type="checkbox"/> Do office work     | <input type="checkbox"/> Be a chef at an event   |
| <input type="checkbox"/> Do graphic design              | <input type="checkbox"/> Design sound       | <input type="checkbox"/> Design and sew costumes |
| <input type="checkbox"/> Other (please specify) _____   |   |  |

### MY SCHEDULE IS:

- Very flexible. I'm often available during weekdays.  
 Somewhat flexible. I can help on the occasional morning or afternoon during the week.  
 Not very flexible at all, but I've got some free time on evenings and weekends.

If you would like to mail this (and you're always welcome to enclose a tax-deductible contribution), you can send it to: **The 52nd Street Project**, 500 West 52nd St., New York, NY 10019. Or fax it to (212) 333-5598.

## Don't Miss Our Upcoming Shows!

# PUNS IN THE OVEN "TOO"

The Tyler Hill, PA Batch of  
the 2001 One-on-Ones

August 23-26  
right here at E.S.T.

Same great theme, but with new  
kids, new adults, and all-new plays.



# PLAYBACK

November, 2001

First a kid writes a short play. Then, an adult writes an "answer" play. Then, the two of them perform both plays. Multiply this equation by seven and you've got an entire show.



December, 2001

In September, 10 kids brand-new to the Project will begin a Playmaking class taught by Project Playmaking Director Michael Bernard. Come and see their final plays performed by adult professional actors.

The 52nd Street Project is a non-profit organization that brings children from the Hell's Kitchen neighborhood together with professional theater artists to create original theater. **Puns In The Oven** is a production of our One-on-One program, which is designed to give children the opportunity to go away for one-week stays in the country and enjoy the undivided attention of a professional theater artist who serves as friend, mentor, and collaborator. The Project is delighted to return to the Ensemble Studio Theatre, where we have been performing since our inception in 1981. We gratefully acknowledge the fact that if E.S.T. wasn't here, we'd be nowhere.

### The 52nd Street Project Board of Directors

Ben Barenholtz

Lisa Benavides

Rachel Chanoff

Heidi Ettinger

Wendy Ettinger, *chair emeritus*

Louis P. Friedman

Stephen Graham

Larry Jones

James McDaniel

Frances McDormand, *chair*

Patricia M. Murphy, Esq.

Carol Ochs

Willie Reale

Gus Rogerson

José Soto, Jr.,

*alumni boardmember*

Pamala Tyson

Laura Valeroso

Wendy vanden Heuvel

Jenny Wiener

### Special Thanks

First of all, a hearty helping of gratitude to these folks for housing adults and kids: Pat McQuade & Martha Velie-Gass; Jane Muskey & Tony Goldwyn; Rita & Steve Draper, Jennifer & Elliot Taubman; Ron, Judy & Kevin Tierney; Virginia Dare, Joya Verde & Anthony; Josie Merck & Jim Stevenson. Sincere thanks to our chefs Pat McQuade & Martha Velie-Gass; our main house hosts Dr. Christina Biaggi & Pat Walsh; Lynn Reale, Kate, Ruth & Harold at Block Island Realty; Aldo's; Prudy & The Ice Cream Place for the free treats; Glenn & Annie Hall; McQuade's Market; Interstate Navigation; Bill Bendokis & New England Air; Robin Morse & Lucia May Rogerson; Bruce MacVittie & Sophia Ochs MacVittie; Wendy vanden Heuvel, Brad Coley & Lila Blue Coley; Greg MacPherson & Jane Perlmutter for the air excursions; Jenny Ritter; Amanda Gass; John & Joanne Warfel; Kirk Littlefield; and finally, Joe and Cam at Smuggler's Cove Sailing School.

### In-Kind Contributions

Curt, Jamie, Matt, Tim, and everyone at E.S.T. Neil A. Mazzella and Hudson Scenic Studios, the Murphy Law Office, Iris A. Brown, Ron Kastner and Capital Printing, Au'Some Candies, Big Apple Lights, Coleman, The Gap, Noggin, The Printing Store, Scholastic, Inc., Seagram's Chateau & Estate Wines, Shapiro & Lobel, Sesame Workshop, Watkins, Inc., Mayor's Office of Film & Television, Boylan's Bottling Co., David Sneddon & Fairway Market, Women's Interart, Andy Millon, Steve Olsen & The Westbank Cafe, Imaginary Studios, Robert Goldberg and Yorke Construction.

## PUNS IN THE OVEN - ACT I

All original music composed by Kim D. Sherman except where noted (\*)  
"Puns In The Oven Theme Song" lyrics by John L. Sheehy

### BETTY BOLD AND THE COOTIE CAPER

Written & Directed by Josh Lewis for Ani Kehr, age 11

Betty Bold ..... Ani Kehr  
Principal ..... Gus Rogerson  
Jerry/Weez/Randy ..... Josh Lewis  
Susie ..... Mayleen Cancel  
Other kids ..... Mary Vamvoukakis, Noel Polanco, Johnathan Roldan

*"Betty Bold"* music & lyrics by Josh Lewis

### THE JOKE'S ON YOU

Written & Directed by Priya Ayyar for Suzette Santana, age 10

Asia/Princess ..... Suzette Santana  
Coco/Maid ..... Priya Ayyar  
Peasants ..... Mayleen Cancel and Sarah Petersiel  
Announcer ..... John Sheehy

*"Right Under My Nose"* lyrics by Priya Ayyar and *"Tell A Joke"* lyrics by Priya Ayyar, music by Kim D. Sherman and Suzette Santana.

### GRAMMA LESSON

Written by Willie Reale. Directed by Willie Reale & Cecilia Arana for Octavia Rodriguez, age 10

Nonalita ..... Octavia Rodriguez  
Angie ..... Cecilia Arana

*"According To St. Anthony"* lyrics by Willie Reale

### I NEVER FANGED FOR MY FATHER

Written by Chris Regan. Directed by Godfrey L. Simmons, Jr. for Wonkezeh Newenle, age 12

Harry Wolf ..... Wonkezeh Newenle  
Howland Wolf ..... Godfrey L. Simmons, Jr.  
Mosquito Man ..... Josh Lewis  
Lycanthrope Singers ..... Sarah Petersiel, Mary Vamvoukakis

*"When the Moon is Full"* lyrics by Susannah Keagle

### THE MYSTERY OF THE SOBBING SISTER

By Theresa Rebeck. Directed by Susan McGinnis for Katherine Acosta, 11

Detective Maura Marino ..... Katherine Acosta  
Lola Pennymaker ..... Susan McGinnis  
Monster ..... Gus Rogerson

*"In the Dead of Night"* lyrics by Theresa Rebeck

👉 **Intermission!** 👈

## ACT II

### MOUNTAIN MAN

Written & Directed by Robert Sean Leonard for Jeremy Butler, age 10

Mountain Man ..... Jeremy Butler  
Clark ..... Robert Sean Leonard  
Mountain Men Chorus ..... MENERGY III

*\*\*"Sublime, the Mountain"* music & lyrics by Robert Sean Leonard, *"Solitude"* lyrics by Robert Sean Leonard

### JASMINE OF THE SQUARES

Written & Directed by Kim Sykes for Ariana Casablanca, age 11

Jasmine ..... Ariana Casablanca  
Jasmine's Mom/ Kathy ..... Kim Sykes  
Carlos ..... John Sheehy

*"I Like It"* lyrics by Kim Sykes; *"Without Math"* lyrics by John Sheehy

### WITCHES!

Written by Megan Sandberg-Zakian, Directed by Megan Sandberg-Zakian & Zabryna Guevara for Britney Castro, age 11

Margaret ..... Britney Castro  
Agnes ..... Zabryna Guevara  
Evil Mob ..... Mayleen Cancel, Noel Polanco,  
Mary Vamvoukakis, and Gus Rogerson

*"Witches!"* lyrics by Megan Sandberg-Zakian

### BOB THE DRAGON

Written by Joe Mihalow. Directed by Doug Lockwood for Alex Kehr, age 10

Bob ..... Alex Kehr  
Announcer ..... Sarah Petersiel  
Chet Rockman ..... Doug Lockwood  
Alfredo Duchamp ..... John Sheehy

*"The Game"* lyrics by John Sheehy & Joe Mihalow

### THE ANGEL ON EIGHTEEN WHEELS

Written & Directed by George Babiak for Frankie Ventura, age 11

Nevada Joe Farnsworth ..... Frankie Ventura  
Trooper Wayne Ledbetter ..... George Babiak  
Cookie ..... Sarah Petersiel  
Butch Rawlins ..... Noel Polanco  
Little Girl ..... Mayleen Cancel

*"Ballad of a Trucker"* lyrics by George Babiak

The 52nd Street Project gratefully acknowledges the support of the following foundations and corporations: Barker Welfare Foundation, The Bamsley Foundation, Blythmour Corporation, Capital Research Company, Carnegie Corporation of New York, Comedy Central, Consolidated Edison, The Dammann Fund, Deutsche Bank of Americas Foundation, The Dramatists Guild Fund, Eleanor, Dramatists Play Service, Adam & Mel Dubin Foundation, Doris Duke Charitable Foundation, The Educational Foundation of America, Entertainment Weekly, Ford Foundation, The Fan Fox & Leslie R. Samuels Foundation, The Horace W. Goldsmith Foundation, The Hennessy Foundation, Hudson Scenic Studio, Betty E. & George B. Kaiser Foundation, Rita J. and Stanley H. Kaplan Foundation, Lloyds TSB Bank plc, James A. Macdonald Foundation, Ann M. Martin Foundation, The Andrew W. Mellon Foundation, Helen Merrill, Ltd., J.P. Morgan Charitable Trust, The William Morris Agency, Mosaic Entertainment, The New World Foundation, The New York Times Company Foundation., Newman's Own, Paramount Pictures, Laura Pels Foundation, Staging and Design, Inc., Harold & Mimi Steinberg Charitable Trust, The Surdna Foundation, Susquehanna, Theater Communications Group, John A. Vassiliaros & Sons, Inc., The Vervane Foundation, West Bank Cafe, Yorke Construction Corporation. In addition the following individuals made gifts of ove \$150 this year (list is current as of 7/25/01)

Anonymous	Terry Fitzpatrick & Liliiana Amador-Marty & Frank Marty	James Waterston & Line Lillevik	Donald Rothschild & Margo Lion
Mark Lanow & Joanne Astrow	Alexa Fogel	Jessica Lissy	Lottchen Shivers
Mary Bacon & Andrew Leynse	Katherine Foster	Adrienne Lobel & Mark Linn Baker	Kenneth Rothstein
June Ballinger & Michael Goldstein	David Frankel	Richard & Susan Lobel	Alexander Roy
Talia Balsam & John Slattery	Eric & Juli Frankel	Charles Loutrell	Steve Sabba
Ben Barenholtz	Naomi Freundlich & Charles Miles	Chris & Sally Lutz	Laura Sametz
Benny Bartley	Louis & Patrice Friedman	John Lyons	Tim & Lisa Sanford
Jessica Bauman	Hank Gallo	Marsue & Peter MacNicol	Karin & Tom Schall
Laurie Becker & Rick Sweren	Victor Garber	Paul & Lauren Mandell	Beth Schneider
Gregory Bello	Beth Gardiner	Brian & Marsha Mannain	Maury Schott
Lisa Benavides & Tim Nelson	Rose Gasner & Larry Chertoff	Elizabeth Manne	Marc Segan
Barry & Myrna Bernard	Joseph & Margaret Gazdak	Peter Manning & André Bishop	Stefan Selig
Brian Swardstrom & Bonnie Bernstein	Hillel & Celia Gershenson	Ali Marsh	Jeffrey Soper & Joshua Lehrer
Alexander & Elizabeth Bernstein	Alexandra Gersten & John A. Vassiliaros	Jesse L. Martin	Alyson Shapero
Stephen Bernstein	Willie Reale & Jenny Gersten	Dave & Alicia Matthews	Aaron & Elaine Shapiro
Vicky Bijur & Ed Levine	Jilian Cahan Gersten	Drew McCoy & Amy Aquino	Jonathan Sheffer
Jeanette & Samuel Black	Ileen Getz & Mark Grinnell	Paul Reale & Barbara McCrane	William Holtzman & S. Sylvia Shepard
Lewis Black	Nancy Giles	Timothy Murtha & Elizabeth McDermott	Reed Birney & Connie Shulman
Tessa Blake	Lloyd & Kilty Gilmour	Fran McDormand & Joel Coen	Meg Simon
Mitchell Lemsky & Jane Bodle	Bob Glennon	Anne Meara & Jerry Stillier	Adam Felber & Jeanne Simpson
Jane Bolster & Steve Wertimer	Judy Goldman & Michael Pillingier	Alan & Janis Menken	Phillip K. & Gloria W. Smith
Buzz Bovshow	Stephen & Cathy Graham	Chia Messina	Abigail Rose Solomon
Alan Braverman	Connie Grappo & Lee Wilkof	Audrey & Danny Meyer	Dr. David Solowiejczyk
Kathy Briggs	Michael Greif & Jonathan Fried	Dean Michaels	John Steber & Robert Shaffron
Becky Browder & Ted Neustadt	Mary Grieco	Ross & Beth Moore	James Neuberger & Helen Stambler
Susan Bruce & Peter Hedges	Emily Grishman & Susan Sampliner	John Morning	Jean Stein
Peter Jay Fernandez & Denise Burse	Lisa Gugenheim	Robin Morse & Gus Rogerson	Ben & Christine Stillier
Kate Burton & Michael Ritchie	Evan Handler	Patricia M. Murphy, Esq. & Adam Spilka	Abbot B. Stranahan
Cora Cahan & Bernard Gersten	Jane & Jonathan Heine	Tony Goldwyn & Jane Musky	Donald Margulies & Lynn Street
Mitchell Semel & Colleen Carroll	Amy Henkels	Geoffrey Nauffts	Susanna Styron & Darrell Larson
Linda & Arthur Carter	David Herdrich & Elizabeth Palmer Herdrich	Randy & Rona Nelson	Daniel Sweeney
Rachel Chanoff	Peter Herdrich & Karen Trott	Rurth Nelson	Mariko Tada
Ellen Chenoweth	Lieta Hesen-Cohen & Richard Cohn	Mark Nesselson, M.D. & Elliott Rosenblum	Jay & Rachel Tarses
Glenda Chesshir	Caroline Hon	Cynthia Nixon	Mary Lou Teel & Peter Freundlich
Marissa & Travis Chibas	Michelle Hurst	Steven O'Neill	Tracy Thorne & Edmund Lewis
Richard Frankel & Kathleen Clark	Virginia & Richard Irwin	Carol Ochs & Bruce MacVittie	Kevin O'Rourke & Edith Thurber
Jerome Cohen Congress	Sy Jacobs	Jacki Ochs & Jan Kroeze	Gina Torres
Jace Alexander & Maddie Corman	Whitney Scott & Peter Jacobson	Paul & Maria Onderdonk	Anne Torsiglieri
Max Mayer & Catherine Corpeny	Linda Janklow	Greg MacPherson & Jane Perlmutter	Joan Vail & John Thorne
Margaret Crimmins	Macon R. & Michael B. Jessop	Steven & Margot Peter	Laura Valeroso & David Seidman
George & Cathy Crow	Tom Slaughter & Marthe Jocelyn	Bat-Sheva & Thomas Peters	Robert Abrams & Cynthia Vance
Cameron Crowe	Amanda Johns	Peter & Ana Rosa Phillips	Wendy vanden Heuvel & Brad Coley
Stephen & Sandra Crudgington	Julia A. Johns	Susan Ochs Phillips	John A. Vassallo
Tom Cruise	Andrea Johnson	Oliver Platt & Camilla Campbell Platt	Borah & Mildred Walton
Arthur Dantchik	Traci Paige Johnson & Robert Mowen	Richard Polatchek	Anita Waxman
Peter and Judith Dawkins	Cherry Jones & Mary O'Connor	Jeremy Posner	Sally & Lenny Weiss
Edward & Joanne DiRugeri	Larry & Mary Jones	Dean & Leslie Potashner	Daniel Wiener
Jon Divis & Gene Reilly	Maurice Kanbar	Gigi Pritzker Pucker & Michael Pucker	Jenny Wiener
Richard & Rebecca Dresser	Lisa A. Kauffman	Christopher Randolph	Michael & Zena Wiener
Christopher & Karen Eddowes	Paul McCrane & Dana Kellin	Peter & Helen Randolph	Elizabeth Williams & Joseph Forte
Mario Egozi	Seth & Beth Klarman	Alysia Reiner & David Basche	Jan Wilson & Saula Cutter
David Eigenberg	Joana & Jason Kliot	Lucy E. Retan	Donald Windham
Ned Eisenberg	Mary Kong	Kate & Chris Robinson	Sarah Winkler & Simon Leopold
Sophia & Gordon Elliott	Judy Kuhn & David Schwab	Loree Rodkin	John Woo
Barbara Ettinger	Allan & Nanette Larson	David & Anita Rogerson	Joanne Woodward & Paul Newman
Barbara Ettinger & Sven Huseby	Kate Lear & Jonathan LaPook	Clifford & Betsy Ross	Jeffrey & Janine Yass
Heidi Ettinger	Robert Sean Leonard	Daryl Roth	James & Mary Lin Yoshimura
Wendy Ettinger & Derek McLane	Becky & Steven Lewis		Richard Blackstone & Yldez Yuksek
Hannah Finn & John Wiltshire			Virginia Zakian & Robert Sandberg
Billy Finnegan			Stuart Zicherman
Matt Williams & Angelina Fiordellisi			

The 52nd Street Project presents The Wiener Family Foundation One-on-Ones

# PUNS IN THE OVEN "TOO"



AUGUST 23-26, 2001

## THE ENSEMBLE STUDIO THEATRE

549 WEST 52ND ST., NEW YORK CITY

# PUNS IN THE OVEN

## PLAYS ON WORDS

The 2001 Tyler Hill  
One-on-Ones  
August 23-26  
The Ensemble Studio Theatre

### The 52nd Street Project Staff:

Gus Rogerson, Artistic Director  
Carol Ochs, Executive Director  
Michael Bernard, Associate Artistic Director  
John Sheehy, Director of Development and Marketing  
George "X-Acto" Babiak, Production Manager  
Julie Feldman, Director of Education  
Megan Sandberg-Zakian, Volunteer Coordinator  
Chris Ceraso, Teen Dean  
Liz Bell, Education Assistant  
Iris A. Brown, Graphic Designer  
Mayleen Cancel and Lorraine Zambrano, Receptionists  
Sarah Petersiel, Intern



### Production Staff

#### Composer:

Kim D. Sherman

#### Music Director:

David Gaines

#### Set Designer:

Kevin Joseph Roach

#### Lighting Designer:

Greg MacPherson

#### Costume Designer:

Crystal Thompson

#### Sound Designer: Maury Schott

#### Stage Manager:

Elissa Errick

#### Slide Designer:

Mike Sell

#### "Puns" Illustration:

Mike Sell

### Prop Design Team:

George Babiak, Elissa Errick,  
Julie Gold, Ivana Granados,  
Sarah Petersiel, Shirley Rumierk,  
John Sheehy

### Furniture Crew:

Rick Meese and Alex Metzler

### Prop Crew:

Judy Agosto, Wonkezeh  
Newenle, Sarah Petersiel,

### Load-in Crew:

Elissa Errick, Amy Johnston,  
Sarah Petersiel

### House Managers:

Karin Schall, Liz Flahive

### Chef: Eric Karpeles

### Proj Grad Counselor: Diana Rojas



NATIONAL  
ENDOWMENT  
FOR THE ARTS

The One-on-One Program is made possible with public funds from the National Endowment for the Arts; The New York State Council on the Arts, a state agency; the Department of Youth and Community Development; and the New York City Department of Cultural Affairs Cultural Challenge Program. The 52nd Street Project is a member of Art/NY and a participant in the New Generations Program, funded by Doris Duke Charitable Foundation/The Andrew W. Mellon Foundation and administered by Theatre Communications Group, the national organization for the American Theater.

State of the Arts



NYSCA

## COOL STUFF ON SALE IN THE LOBBY!

The Fabulous Flyer Bar .....\$2.00 & \$1.50  
and featuring Shel Silverstein's "Five and Twoey" logo:  
Project T-shirts (NEW design) .....\$12.00  
Project Tank Tops .....\$12.00  
Project Caps (NEW design) .....\$15.00  
Project Mugs .....\$5.00  
Project Pencil 3-pack (now in RED!) .....\$1.00

Thank you for coming to **PUNS IN THE OVEN!** If you are not on our mailing list (or if your address has changed), please fill out this form and give it to us on your way out or mail it to the address below. We would also like to know if you are interested in becoming a volunteer. We need help in **all areas**, so be sure to fill out the entire form.

### PLEASE ADD ME TO YOUR MAILING LIST:

8/01

NAME: \_\_\_\_\_

ADDRESS: \_\_\_\_\_

ZIP \_\_\_\_\_

HOME PHONE: \_\_\_\_\_

DAYTIME PHONE: \_\_\_\_\_

E-MAIL ADDRESS: \_\_\_\_\_

MY OCCUPATION: \_\_\_\_\_

MY HOBBIES: \_\_\_\_\_

### YES, I WOULD LIKE TO BE OF HELP. I CAN:

- |   |   |  |
|---|---|--|
| <input type="checkbox"/> Help load in and out for shows | <input type="checkbox"/> Draw and/or paint  | <input type="checkbox"/> Help kids with homework |
| <input type="checkbox"/> Hang lights                    | <input type="checkbox"/> Help with mailings | <input type="checkbox"/> Teach kids a skill      |
| <input type="checkbox"/> Work on a backstage crew       | <input type="checkbox"/> Do office work     | <input type="checkbox"/> Be a chef at an event   |
| <input type="checkbox"/> Do graphic design              | <input type="checkbox"/> Design sound       | <input type="checkbox"/> Design and sew costumes |
| <input type="checkbox"/> Other (please specify) _____   |   |  |

### MY SCHEDULE IS:

- Very flexible. I'm often available during weekdays.  
 Somewhat flexible. I can help on the occasional morning or afternoon during the week.  
 Not very flexible at all, but I've got some free time on evenings and weekends.

If you would like to mail this (and you're always welcome to enclose a tax-deductible contribution), you can send it to: **The 52nd Street Project**, 500 West 52nd St., New York, NY 10019. Or fax it to (212) 333-5598.

## Don't Miss Our Upcoming Shows!

👂 **PLAYBACK 2001** 👂

# Wha' Happen?

PLAYS WITH TWO

SIDES

November, 2001

First a kid writes a short play. Then, an adult writes an "answer" play. Then, the two of them perform both plays. Multiply this equation by seven and you've got an entire

# FORK IN THE ROAD

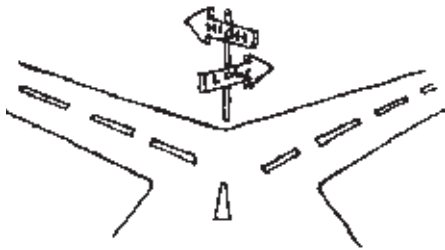

**10 CHOICE PLAYS**

December,  
2001

In September, 10 kids brand-new to the Project will begin a Playmaking class taught by Project Playmaking Director Michael Bernard. Come and see their final plays performed by adult professional actors.

The 52nd Street Project is a non-profit organization that brings children from the Hell's Kitchen neighborhood together with professional theater artists to create original theater. **Puns In The Oven** is a production of our One-on-One program, which is designed to give children the opportunity to go away for one-week stays in the country and enjoy the undivided attention of a professional theater artist who serves as friend, mentor, and collaborator. The Project is delighted to return to the Ensemble Studio Theatre, where we have been performing since our inception in 1981. We gratefully acknowledge the fact that if E.S.T. wasn't here, we'd be nowhere.

### The 52nd Street Project Board of Directors

Ben Barenholtz

Lisa Benavides

Rachel Chanoff

Heidi Ettinger

Wendy Ettinger, *chair emeritus*

Louis P. Friedman

Stephen Graham

Larry Jones

James McDaniel

Frances McDormand, *chair*

Patricia M. Murphy, Esq.

Carol Ochs

Willie Reale

Gus Rogerson

José Soto, Jr.,

*alumni boardmember*

Pamala Tyson

Laura Valeroso

Wendy vanden Heuvel

Jenny Wiener

### Special Thanks

Our trip to Pennsylvania wouldn't have been possible if it weren't for our stalwart host families, who put up both kids and adults at their homes. Thanks go to Linda, Bill & Sean Cobb; Linda, Bill & Daniel Halvorsen; Andrea, Chuck, Melanie & Emma Heyn; Deborah, David, Imogen, Benita & Sam Pursch; Frank & Pat Stoeckle; Sally & Lenny Weiss; Debbie, Frosty & Rio Myers; Richard Grunn & Tasha Williams; Katie Homans & Patterson Sims & Mardette & Lally; & Pete Snyder & Cathy Dodge.

Sincere thanks to Wendy Townsend and Mark Keoppen, Martha Sader; David Sneddon & Steve Jenkins and The Fairway Market, Vanessa Valdes & Marcia Dunsmore. Extra-special thanks to our amazing hosts Mike Sell & Eric Karpeles (and Walter the Cat, too.)

### In-Kind Contributions

Curt, Jamie, Matt, Tim, and everyone at E.S.T. Neil A. Mazzella and Hudson Scenic Studios, the Murphy Law Office, Iris A. Brown, Ron Kastner and Capital Printing, Au'Some Candies, Big Apple Lights, Coleman, The Gap, Noggin, The Printing Store, Scholastic, Inc., Seagram's Chateau & Estate Wines, Shapiro & Lobel, Sesame Workshop, Watkins, Inc., Mayor's Office of Film & Television, Boylan's Bottling Co., David Sneddon & Fairway Market, Women's Interart, Andy Millon, Steve Olsen & The Westbank Cafe, Imaginary Studios, Robert Goldberg and Yorke Construction.

## PUNS IN THE OVEN, TOO - ACT I

All original music composed by Kim D. Sherman except where noted (\*)  
"Puns In The Oven Theme Song" lyrics by John L. Sheehy

### A COD PIECE

written by Jackie Reingold & directed by Jackie Reingold & Lisa Leguillo for Marilyn Sanchez, age 12

Ima Cod .....Marilyn Sanchez  
Bea A. Starfish .....Lisa Leguillo  
Lobster Mobster .....Ed Vassallo  
Mussel Man .....Wonkezeh Newenle, Mike Sell (8/23 only)

"Sad to Be a Cod Song" & "Happy to Be a Cod Song" lyrics by Jackie Reingold

### END OF THE LINE

written by Gus Rogerson & directed by Catherine Mueller for Anthony Mejia, age 11

Red Green .....Anthony Mejia  
Eunice/Paleontologist/Woman .....Catherine Mueller  
Thirsty woman .....Judy Agosto

"Red's Big Problem" lyrics by Gus Rogerson

### SHOWDOWN IN SEVILLA

written & directed by Matt Saldívar for Berto Rodriguez, age 12

Benjamin .....Berto Rodriguez  
Julio .....Matt Saldívar  
Beatrice .....Sarah Petersiel  
Pancakes .....Michael Potts  
Desperados .....Male Company

"Cielito Lindo" \*traditional

### ONE TOUGH COOKIE CRUMBLES

written by John Sheehy & directed by Denise Burse for Lizette Natera, age 13

Ella .....Lizette Natera  
Madam Borgia .....Denise Burse

"Just Dessert" lyrics by John Sheehy

### BOLT

written by Dan Berrett & directed by Michael Potts for Stephen Galimidi, 11

Bolt .....Stephen Galimidi  
Parker/Announcer .....Michael Potts  
Racehorses .....The backstage crew

"In the World Out There," lyrics by Dan Berrett

☞ **Intermission!** ☜

## ACT II

### A SHAGGY FLY STORY

written by Tim Blake Nelson & directed by Ed Vassallo for Jonathan Hagemeyer, age 13

Spivey .....Jonathan Hagemeyer  
Flem .....Ed Vassallo  
Judge .....Peter Jay Fernandez  
Court officer .....Alex Metzler

"My Best Friend," & "Sing-a-Long" lyrics by Tim Blake Nelson

### SLASHDANCE

written & directed by Adam Felber for Ivana Granados, age 11

Nicole .....Ivana Granados  
Cindy .....Jeanne Simpson  
Big Steve/Cactus .....John Sheehy

"We Can Dance," lyrics by Adam Felber, Beatbox by Ed Vassallo & Justin Aponte

### MELLOW DRAMA

written by Willie Reale & directed by Peter Jay Fernandez for Leah Galimidi, age 13

Widow Bizby .....Leah Galimidi  
Mr. Lecher miser/Leopold .....Peter Jay Fernandez

"Woe Is Me" & "Whoa, Not A Clown" lyrics by Willie Reale

### TAKING THE CAKE

written & directed by Anne Torsiglieri for Wendy Rivera, age 13

Lulu .....Wendy Rivera  
Ethel .....Anne Torsiglieri  
Doctor .....Michael Bernard

"I Bake" & "Cooking Lesson" lyrics by Anne Torsiglieri

### CONJOINED TWIN PRISON BREAK

written & directed by Michael Bernard for Justin Aponte, age 13

Schmill .....Justin Aponte  
Bill .....Michael Bernard  
Prison Guard .....Alex Metzler

"Sometimes" lyrics by Michael Bernard



The 52nd Street Project gratefully acknowledges the support of the following foundations and corporations: Barker Welfare Foundation, The Bamsley Foundation, Blythmour Corporation, Capital Research Company, Carnegie Corporation of New York, Comedy Central, Consolidated Edison, The Dammann Fund, Deutsche Bank of Americas Foundation, The Dramatists Guild Fund, Eleanor, Dramatists Play Service, Adam & Mel Dubin Foundation, Doris Duke Charitable Foundation, The Educational Foundation of America, Entertainment Weekly, Ford Foundation, The Fan Fox & Leslie R. Samuels Foundation, The Horace W. Goldsmith Foundation, The Hennessy Foundation, Holland Lodge Foundation, Hudson Scenic Studio, Betty E. & George B. Kaiser Foundation, Rita J. and Stanley H. Kaplan Foundation, Lloyds TSB Bank plc, James A. Macdonald Foundation, Ann M. Martin Foundation, The Andrew W. Mellon Foundation, Helen Merrill, Ltd., J.P. Morgan Charitable Trust, The William Morris Agency, Mosaic Entertainment, The New World Foundation, The New York Times Company Foundation, Newman's Own, Paramount Pictures, Laura Pels Foundation, Roulette Entertainment Staging and Design, Inc., Harold & Mimi Steinberg Charitable Trust, The Surdna Foundation, Susquehanna, Theater Communications Group, John A. Vassilaros & Sons, Inc., The Vervane Foundation, West Bank Cafe, Yorke Construction Corporation. In addition the following individuals made gifts of over \$150 this year (list is current as of 10/30/01)

- |                                      |  |  |                                      |
|--------------------------------------|--|--|--------------------------------------|
| Anonymous                            | Terry Fitzpatrick & Stephen Perrepelek     | Becky & Steven Lewis                     | Loree Rodkin                         |
| Liliana Amador-Marty & Frank Marty   | Stephen Perrepelek                         | James Waterston & Line Lillevik          | David & Anita Rogerson               |
| Mark Lanow & Joanne Astrow           | Alexa Fogel                                | Margo Lion                               | Clifford & Betsy Ross                |
| Mary Bacon & Andrew Leynse           | Katherine Foster                           | Jessica Lissy                            | Daryl Roth                           |
| June Ballinger & Michael Goldstein   | David Frankel                              | Adrienne Lobel & Mark Linn Baker         | Donald Rothschild & Lottchen Shivers |
| Talia Balsam & John Slattery         | Eric & Juli Frankel                        | Richard & Susan Lobel                    | Kenneth Rothstein                    |
| Ben Barenholtz                       | Naomi Freundlich & Charles Miles           | Charles Loutrell                         | Alexander Roy                        |
| Benny Bartley                        | Louis & Patrice Friedman                   | Chris & Sally Lutza                      | Steve Sabba                          |
| Jessica Bauman                       | Hank Gallo                                 | John Lyons                               | Laura Sameletz                       |
| Laurie Becker & Rick Sweren          | Victor Garber                              | Marsue & Peter MacNicol                  | Tim & Lisa Sanford                   |
| Gregory Bello                        | Beth Gardiner                              | Paul & Lauren Mandell                    | Karin & Tom Schall                   |
| Lisa Benavides & Tim Nelson          | Rose Gasner & Larry Chertoff               | Brian & Marsha Mannain                   | Beth Schneider                       |
| Barry & Myrna Bernard                | Joseph & Margaret Gazdak                   | Elizabeth Manne                          | Maury Schott                         |
| Brian Swardstrom & Bonnie Bernstein  | Jonathan Gazdak                            | Peter Manning & André Bishop             | Marc Segan                           |
| Alexander & Elizabeth Bernstein      | Hillel & Celia Gershenson                  | Richard P. Martin                        | Stefan Selig                         |
| Stephen Bernstein                    | Alexandra Gersten & John A. Vassilaros     | Ali Marsh                                | Jeffrey Sella & Joshua Lehrer        |
| Vicky Bijur & Ed Levine              | Willie Reale & Jenny Gersten               | Jesse L. Martin                          | Alyson Shapero                       |
| Jeanette & Samuel Black              | Jillian Cahan Gersten                      | Dave & Alicia Matthews                   | Aaron & Elaine Shapiro               |
| Lewis Black                          | Ileen Getz & Mark Grinnell                 | Drew McCoy & Amy Aquino                  | Bernice Baruch Shawl                 |
| Tessa Blake                          | Nancy Giles                                | Paul Reale & Barbara McCrane             | Jonathan Sheffer                     |
| Mitchell Lemsky & Jane Bodle         | Lloyd & Kilty Gilmour                      | Timothy Murtha & Elizabeth McDermott     | William Holtzman & S. Sylvia Shepard |
| Jane Bolster & Steve Wertimer        | Bob Glennon                                | Fran McDormand & Joel Coen               | Reed Birney & Connie Shulman         |
| Buzz Bovshow                         | Judy Goldman & Michael Pillingier          | Anne Meara & Jerry Stiller               | Meg Simon                            |
| Alan Braverman                       | Fredrick & Nancy Goldman                   | Alan & Janis Menken                      | Adam Felber & Jeanne Simpson         |
| Kathy Briggs                         | Stephen & Cathy Graham                     | Chia Messina                             | Phillip K. & Gloria W. Smith         |
| Becky Browder & Ted Neustadt         | Connie Grappo & Lee Wilkof                 | Audrey & Danny Meyer                     | Abigail Rose Solomon                 |
| Susan Bruce & Peter Hedges           | Michael Greif & Jonathan Fried             | Dean Michaels                            | Dr. David Solowiejczyk               |
| Peter Jay Fernandez & Denise Burse   | Mary Grieco                                | Janet Mornjian & Steve Olsen             | John Steber & Robert Shaffron        |
| Kate Burton & Michael Ritchie        | Emily Grishman & Susan Sampliner           | Ross & Beth Moore                        | James Neuberger & Helen Stambler     |
| Cora Cahan & Bernard Gersten         | Lisa Gugenheim                             | John Morning                             | Jean Stein                           |
| Mitchell Semel & Colleen Carroll     | Evan Handler                               | Alfred Morris                            | Ben & Christine Stiller              |
| Linda & Arthur Carter                | Lynn Harris                                | Robin Morse & Gus Rogerson               | Abbot B. Stranahan                   |
| Rachel Chanoff                       | Jane & Jonathan Heine                      | Patricia M. Murphy, Esq. & Adam Spilka   | Donald Margulies & Lynn Street       |
| Ellen Chenoweth                      | Amy Henkels                                | Tony Goldwyn & Jane Musky                | Susanna Styron & Darrell Larson      |
| Glenda Chesshir                      | David Herdrich & Elizabeth Palmer Herdrich | Geoffrey Nauffts                         | Daniel Swee                          |
| Marissa & Travis Chibas              | Peter Herdrich & Karen Trott               | Pam Nelson                               | Mariko Tada                          |
| Richard Frankel & Kathleen Clark     | Lieta Hesen-Cohen & Richard Cohn           | Randy & Rona Nelson                      | Jay & Rachel Tarses                  |
| Jerome Cohen Congress                | Caroline Hon                               | Rurth Nelson                             | Mary Lou Teel & Peter Freundlich     |
| Jace Alexander & Maddie Corman       | Michelle Hurst                             | Mark Nesselson, M.D. & Elliott Rosenblum | Tracy Thorne & Edmund Lewis          |
| Max Mayer & Catherine Corpeny        | Virginia & Richard Irwin                   | Cynthia Nixon                            | Kevin O'Rourke & Edith Thurber       |
| Margaret Crimmins                    | Sy Jacobs                                  | Steven O'Neill                           | Shane Tilson-L'Estrange              |
| George & Cathy Crow                  | Whitney Scott & Peter Jacobson             | Carol Ochs & Bruce MacVittie             | Gina Torres                          |
| Cameron Crowe                        | Linda Janklow                              | Jacki Ochs & Jan Kroeze                  | Anne Torsiglieri                     |
| Stephen & Sandra Crudgington         | Macon R. & Michael B. Jessop               | Paul & Maria Onderdonk                   | Joan Vail & John Thome               |
| Tom Cruise                           | Tom Slaughter & Marthe Jocelyne            | Greg MacPherson & Jane Perlmutter        | Laura Valeroso & David Seidman       |
| Arthur Dantchik                      | Amanda Johns                               | Steven & Margot Peter                    | Robert Abrams & Cynthia Vance        |
| Cathy Dantchik                       | Julia A. Johns                             | Bat-Sheva & Thomas Peters                | Wendy vanden Heuvel & Brad Coley     |
| Peter and Judith Dawkins             | Andrea Johnson                             | Peter & Ana Rosa Phillips                | John A. Vassallo                     |
| Cameron Diaz                         | Traci Paige Johnson & Robert Mowen         | Susan Ochs Phillips                      | Borah & Mildred Walton               |
| Edward & Joanne DiRugeri             | Cherry Jones & Mary O'Connor               | Oliver & Camilla Platt                   | Anita Waxman                         |
| Jon Divis & Gene Reilly              | Larry & Mary Jones                         | Richard Polatohck                        | Sally & Lenny Weiss                  |
| Richard & Rebecca Dresser            | Maurice Kanbar                             | Jeremy Posner                            | Daniel Wiener                        |
| Christopher & Karen Eddowes          | Lisa A. Kauffman                           | Dean & Leslie Potashner                  | Jenny Wiener                         |
| Mario Egozi                          | Paul McCrane & Dana Kellin                 | Gigi Pritzker Pucker & Michael Pucker    | Michael & Zena Wiener                |
| David Eigenberg                      | Stephen Kepniss                            | Christopher Randolph                     | Elizabeth Williams & Joseph Forte    |
| Ned Eisenberg                        | Seth & Beth Klarman                        | Peter & Helen Randolph                   | Jan Wilson & Saula Cutter            |
| Sophia & Gordon Elliott              | Joana & Jason Kilot                        | Theresa Rebeck & Jess Lynn               | Donald Windham                       |
| Barbara Ettinger                     | Mary Kong                                  | Alysia Reiner & David Basche             | Sarah Winkler & Simon Leopold        |
| Barbara Ettinger & Sven Huseby       | Judy Kuhn & David Schwab                   | Lucy E. Retan                            | John Woo                             |
| Heidi Ettinger                       | Allan & Nanette Larson                     | Anthony Rhulen                           | Joanne Woodward & Paul Newman        |
| Wendy Ettinger & Derek McLane        | Kate Lear & Jonathan LaPook                | Kate Hudson & Chris Robinson             | Jeffrey & Janine Yass                |
| Hannah Finn & John Wiltshire         | Robert Sean Leonard                        |  | James & Mary Lin Yoshimura           |
| Billy Finnegan                       |  |  | Richard Blackstone & Yldeez Yuksek   |
| Matt Williams & Angelina Fiordellisi |  |  | Virginia Zakian & Robert Sandberg    |
|                                      |  |  | Stuart Zicherman                     |

The 52nd Street Project presents The 2001 Playback Shows

# WHA' HAPPEN?

PLAYS WITH 2 SIDES



**Fri., Nov. 2 and Sat., Nov. 3 at 7:30 p.m.**

**Sun., Nov. 4 at 3:00 p.m.**

**Theater at St. Clement's Church**

**423 W. 46th St., New York City**



# WHA' HAPPEN?

**PLAYS WITH TWO SIDES**

*The 2001 Playback Shows*  
November 2-4  
Theater at  
St. Clement's Church

**The 52nd Street Project Staff:**

Gus Rogerson, Artistic Director  
Carol Ochs, Executive Director  
Michael Bernard, Associate Artistic Director  
John Sheehy, Director of Development and Marketing  
George "X-Acto" Babiak, Production Manager  
Julie Feldman, Director of Education  
Megan Sandberg-Zakian, Volunteer Coordinator  
Chris Ceraso, Teen Dean  
Liz Bell, Education Assistant  
Iris A. Brown, Graphic Designer  
Mayleen Cancel and Jayme Rosado, Receptionists  
Claire Sother, Intern



**Production Staff**

**Composer:**

Virginia Hart Pike

**Music Director:**

Douglas Nervik

**Set Designer:**

Kevin Joseph Roach

**Lighting Designer:**

Greg MacPherson

**Costume Designer:**

Sheila Kehoe

**Sound Designer:** Maury Schott

**Stage Manager:**

Noël Dawkins

**Slide Designers:**

Christopher Bonanos, Renato Castilho,  
Vickie Clarke, Johann Conforme,  
Katherine Lumb, Tiana Manfred, Monty  
Nicol, Kim Snow, Iwona Waluk

**"Wha' Happen?" Illustrations:**

James Stevenson

**Prop Design Team:**

Anju Andre-Bergmann, George Babiak,  
Chris Bonanos, Jason Gots, Richard  
Hicks, Katherine Lumb, Cara Marcous,  
Natalie Musteata, Monty Nicol, Noel  
Polanco, Christina Ramirez, Iwona  
Waluk

**Furniture Crew:**

Emily Crow and Noel Polanco

**Prop Crew:**

Claire Sother, Anju Andre-Bergmann,  
and Natalie Musteata

**Load-in and Light Hang Crew:**

Mona Arriola, Emily Crow, Moira  
MacDonald, Betsy Rhodes, John  
Salzman, Claire Sother, Jason Wells

**House Managers:** Cara Marcous,  
Susan McGinnis, and Mary Pat Walsh

**Chefs:** Christopher Randolph,  
Karin Schall, and Mary Pat Walsh



**NATIONAL  
ENDOWMENT  
FOR THE ARTS**

The Playback Program is made possible with public funds from the National Endowment for the Arts; The New York State Council on the Arts, a state agency; the Department of Youth and Community Development; and the New York City Department of Cultural Affairs Cultural Challenge Program. The 52nd Street Project is a member of Art/NY and a participant in the New Generations Program, funded by Doris Duke Charitable Foundation/The Andrew W. Mellon Foundation and administered by Theatre Communications Group, the national organization for the American Theater.

State of the Arts



**NYSCA**

## COOL STUFF ON SALE IN THE LOBBY!

The Fabulous Flyer Bar .....\$2.00 & \$1.50  
*and featuring Shel Silverstein's "Fivey and Twoey" logo:*  
Project T-shirts (NEW design) .....\$12.00  
Project T-shirts, long sleeve .....\$15.00  
Project Caps (NEW design) .....\$15.00  
Project Mugs .....\$5.00  
Project Pencil 3-pack (now in RED!) .....\$1.00

Thank you for coming to **WHA' HAPPEN?** If you are not on our mailing list (or if your address has changed), please fill out this form and give it to us on your way out or mail it to the address below. We would also like to know if you are interested in becoming a volunteer. We need help in **all areas**, so be sure to fill out the entire form.

**PLEASE ADD ME TO YOUR MAILING LIST:**

11/01

NAME: \_\_\_\_\_

ADDRESS: \_\_\_\_\_

ZIP \_\_\_\_\_

HOME PHONE: \_\_\_\_\_

DAYTIME PHONE: \_\_\_\_\_

E-MAIL ADDRESS: \_\_\_\_\_

MY OCCUPATION: \_\_\_\_\_

MY HOBBIES: \_\_\_\_\_

**YES, I WOULD LIKE TO BE OF HELP. I CAN:**

- |   |   |  |
|---|---|--|
| <input type="checkbox"/> Help load in and out for shows | <input type="checkbox"/> Draw and/or paint  | <input type="checkbox"/> Help kids with homework |
| <input type="checkbox"/> Hang lights                    | <input type="checkbox"/> Help with mailings | <input type="checkbox"/> Teach kids a skill      |
| <input type="checkbox"/> Work on a backstage crew       | <input type="checkbox"/> Do office work     | <input type="checkbox"/> Be a chef at an event   |
| <input type="checkbox"/> Do graphic design              | <input type="checkbox"/> Design sound       | <input type="checkbox"/> Design and sew costumes |
| <input type="checkbox"/> Other (please specify) _____   |   |  |

**MY SCHEDULE IS:**

- Very flexible. I'm often available during weekdays.  
 Somewhat flexible. I can help on the occasional morning or afternoon during the week.  
 Not very flexible at all, but I've got some free time on evenings and weekends.

If you would like to mail this (and you're always welcome to enclose a tax-deductible contribution), you can send it to: **The 52nd Street Project**, 500 West 52nd St., New York, NY 10019. Or fax it to (212) 333-5598.

## Don't Miss Our Upcoming Shows!

# FORK IN THE ROAD

December 14-16,  
Ensemble  
Studio Theatre

In September, 10 kids brand-new to the Project began a Playmaking class taught by Playmaking Director Michael Bernard. Come and see their final plays performed by adult professional actors.

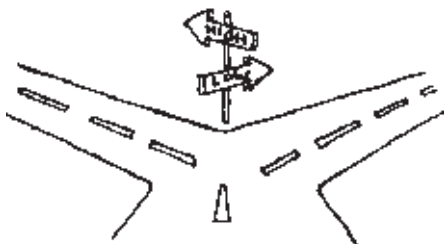

**10 CHOICE PLAYS**

# Table For Two

THE RESTAURANT PLAYS



## THE 2002 TWO-ON-TWOS

In the One-on-One's, a single kid is paired with a single adult. Now you can see *two* kids perform a play written by an adult and directed by *another* adult. Theater to be announced.

The 52nd Street Project is a non-profit organization that brings inner-city children from the Hell's Kitchen neighborhood together with professional theater artists to create original theater. **Wha' Happen?** is a production of our Playback program, in which kid actor/playwrights are taken away for a weekend in Wareham, Massachusetts (very close to Cape Cod) where they write a play. Their adult actor/playwright partners then write "answer plays" in response. For the final production, which you see here tonight, the partners perform both plays back-to-back. All of the kids involved are veterans of the Playmaking classes which were adapted for the Project by Daniel Judah Sklar from his book *Playmaking: Children Writing and Performing Their Own Plays*.

### The 52nd Street Project Board of Directors

Ben Barenholtz  
Lisa Benavides  
Rachel Chanoff  
Heidi Ettinger  
Wendy Ettinger  
Louis P. Friedman  
Stephen Graham, *chair*  
Larry Jones  
James McDaniel  
Frances McDormand

Patricia M. Murphy, Esq.  
Carol Ochs  
Willie Reale  
Gus Rogerson  
José Soto, Jr.,  
*alumni boardmember*  
Pamala Tyson  
Laura Valeroso  
Wendy vanden Heuvel  
Jenny Wiener

### Special Thanks

We're extremely grateful to Peter, Helen, and Christopher Randolph, who made their lovely home in Wareham, Massachusetts available to us over the Columbus Day Weekend. Thanks also to Anita Flanagan for her help with costumes, Vanessa Valdes for her sound advice, and Mother Crafton, Seth, Clarence, Wendy and the rest of the great staff at St. Clement's.

### In-Kind Contributions

Ensemble Studio Theatre, Neil A. Mazzella and Hudson Scenic Studios, the Murphy Law Office, Iris A. Brown, Ron Kastner and Capital Printing, Au'Some Candies, Big Apple Lights, Coleman, The Gap, Noggin, The Printing Store, Scholastic, Inc., Seagram's Chateau & Estate Wines, Shapiro & Lobel, Sesame Workshop, Watkins, Inc., Mayor's Office of Film & Television, Boylan's Bottling Co., David Sneddon & Fairway Market, Women's Interart, Andy Millon, Steve Olsen & The Westbank Cafe, Imaginary Studios, Robert Goldberg and Yorke Construction.



The 52nd Street Project is proud to participate in the NYC Arts Coalition's efforts to "Take Back Our City."

## WHA' HAPPEN? - ACT I

All original music composed by Virginia Pike

### Acceptance Speech

By Christina Ramirez, age 13. Dramaturg: Seret Scott. Director: Kim Sykes

### The Wonderful Adventures of One Rotten Banana

Written by Kim Sykes. Directed by Kim Sykes and Seret Scott

Georgia/Nana .....Christina Ramirez

June/Georgia (part 2)/Susan Lucci/Plantan .....Kim Sykes

"The Green Grass Grows All Around" lyrics by Christina Ramirez, "A Cure For Elmocitis" lyrics by Kim Sykes

### Double Take

By Zaida Natera, age 14 (15 next wk.) Dramaturg/Director: Lenore Pemberton

### Mother Take

By Adriana Trigiani. Director: Lenore Pemberton

Envy/Pride .....Zaida Natera

Jada/Ruby .....Lenore Pemberton

Speaker .....John Sheehy

SYZ .....Natalie Musteata, Anju Andre-Bergmann, Claire Sother

"Two Fly Girls" and "I'm Sorry" lyrics by Zaida Natera

### The Spirit

By Jayme Rosado, age 14. Dramaturg/Director: Liz Tuccillo

### The Spirit, Part II

Written and Directed by Liz Tuccillo

Allan/Andy .....Jayme Rosado

Mom/Mary .....Liz Tuccillo

### Identity Crisis

By Shevonne Hernandez, age 14. Dramaturg: Megan Sandberg-Zakian.

Directed by Gus Rogerson

### Clem 'N' Clementine

Written and Directed by Gus Rogerson

Jayana Rogerson/Clementine .....Shevonne Hernandez

Marco Hernandez/Clem .....Gus Rogerson

Flight attendant .....Emily Crow

The Boss .....Noel Polanco

Cigar Guy .....John Sheehy

Model Girl .....Claire Sother

"Clem 'n' Clementine's Reveille" and "Young In The Mind" lyrics by Gus Rogerson

👉 **Intermission!** 👈

## WHA' HAPPEN? - ACT II

### Foul Play

By Isaac Trujillo, age 14. Dramaturg/Director: Keith Reddin

### Over Overtime

Written and directed by Keith Reddin

Allen .....Isaac Trujillo

Mike .....Keith Reddin

Lewis .....Noel Polanco

Manager .....George Babiak

### Dance, Dance, and Why Not Dance?

By Yazzy Troche, age 15. Dramaturg/Director: Liz Flahive

### I'll Tell You Why Not

Written and Directed by Liz Flahive

Yaaliyah/Mrs. Graziela Garcia Romero Schwartz .....Yazzy Troche

Da Serious One/Manny the Flyer Guy .....Matt Saldívar

Another Flyer Guy .....Noel Polanco

Club People .....The Crew

Announcer/Kid .....Michael Bernard

"Winning or Losing" lyrics by Yazzy Troche, "Mrs. Schwartz's Lament" lyrics by Liz Flahive

### That's The Way Life Is

By Michael Feliciano, age 14. Dramaturg/Director: Carlo Alban

### Life Is That Way

Written by Michael Bernard. Directed by Carlo Alban

Charlie .....Michael Feliciano

Maxwell .....Carlo Alban

Sam .....Natalie Musteata

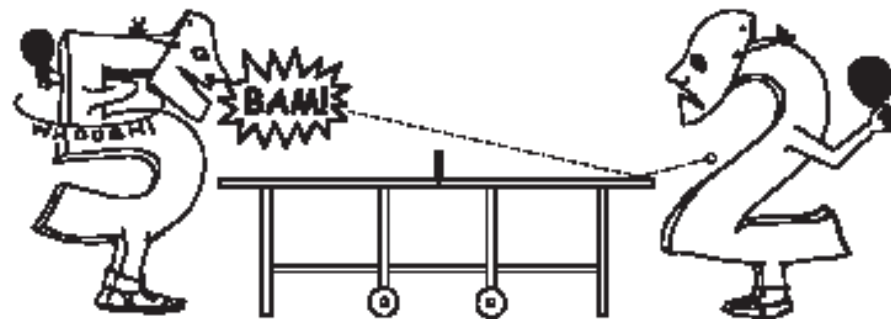

The 52nd Street Project gratefully acknowledges the support of the following foundations and corporations: Barker Welfare Foundation, The Bamsley Foundation, Blythmour Corporation, Capital Research Company, Carnegie Corporation of New York, Comedy Central, Consolidated Edison, The Dammann Fund, Deutsche Bank of Americas Foundation, The Dramatists Guild Fund, Eleanor, Dramatists Play Service, Adam & Mel Dubin Foundation, Doris Duke Charitable Foundation, The Educational Foundation of America, Entertainment Weekly, Ford Foundation, The Fan Fox & Leslie R. Samuels Foundation, The J. Paul Getty Trust, The Horace W. Goldsmith Foundation, The Hennessy Foundation, Holland Lodge Foundation, Hudson Scenic Studio, Betty E. & George B. Kaiser Foundation, Rita J. and Stanley H. Kaplan Foundation, Lloyds TSB Bank plc, James A. Macdonald Foundation, Ann M. Martin Foundation, The Andrew W. Mellon Foundation, Helen Merrill, Ltd., J.P. Morgan Charitable Trust, The William Morris Agency, Mosaic Entertainment, The New World Foundation, The New York Times Company Foundation., Newman's Own, Paramount Pictures, Roulette Entertainment Staging and Design, Inc., Harold & Mimi Steinberg Charitable Trust, The Surdna Foundation, Susquehanna, Theatre Communications Group, John A. Vassilaros & Sons, Inc., The Vervane Foundation, West Bank Cafe, Yorke Construction Corporation. In addition the following individuals made gifts of over \$150 this year (list is current as of 12/10/01)

Anonymous	Alexa Fogel	Robert Sean Leonard	Kate Hudson & Chris Robinson
Liliana Amador-Marty & Frank Marty	Katherine Foster	Becky & Steven Lewis	Loree Rodkin
Mark Lanow & Joanne Astrow	David Frankel	James Waterston & Line Lillevik	David & Anita Rogerson
Mary Bacon & Andrew Leynse	Eric & Juli Frankel	Margo Lion	Clifford & Betsy Ross
June Ballinger & Michael Goldstein	Naomi Freundlich & Charles Miles	Jessica Lissy	Daryl Roth
Talia Balsam & John Slattery	Louis & Patrice Friedman	Adrienne Lobel & Mark Linn Baker	Donald Rothschild & Lottchen Shivers
Ben Barenholtz	Hank Gallo	Richard & Susan Lobel	Kenneth Rothstein
Benny Bartley	Victor Garber	Charles Loutrell	Alexander Roy
Jessica Bauman	Beth Gardiner	Chris & Sally Lutz	Steve Sabba
Laurie Becker & Rick Sweren	Janeanne Garofalo	John Lyons	Laura Sametz
Gregory Bello	Rose Gasner & Larry Chertoff	Grace Lyu-Volckhausen	Tim & Lisa Sanford
Lisa Benavides & Tim Nelson	Joseph & Margaret Gazdak	Marsue & Peter MacNicol	Karin & Tom Schall
Barry & Myrna Bernard	Jonathan Gazdak	Paul & Lauren Mandell	Beth Schneider
Brian Swardstrom & Bonnie Bernstein	Hillel & Celia Gershenson	Brian & Marsha Mannain	Maury Schott
Alexander & Elizabeth Bernstein	Alexandra Gersten & John A. Vassilaros	Elizabeth Manne	Marc Segan
Stephen Bernstein	Willie Reale & Jenny Gersten	Peter Manning & André Bishop	Stefan Selig
Vicky Bijur & Ed Levine	Jilian Cahan Gersten	Richard P. Martin	Jeffrey Seller & Joshua Lehrer
Jeanette & Samuel Black	Ileen Getz & Mark Grinnell	Ali Marsh	Alyson Shapero
Lewis Black	Nancy Giles	Richard Marin	Aaron & Elaine Shapiro
Tessa Blake	Lloyd & Kilty Gilmour	Jesse L. Martin	Bernice Baruch Shawl
Mitchell Lemsky & Jane Bodle	Bob Glennon	Dave & Alicia Matthews	Jonathan Sheffer
Jane Bolster & Steve Wertimer	Judy Goldman & Michael Pillinger	Drew McCoy & Amy Aquino	William Holtzman & S. Sylvia Shepard
Buzz Bovshow	Fredrick & Nancy Goldman	Paul Reale & Barbara McCrane	Reed Birney & Connie Shulman
Alan Braverman	Nancy & Fred Goodman	Timothy Murtha & Elizabeth McDermott	Meg Simon
Kathy Briggs	Stephen & Cathy Graham	Fran McDormand & Joel Coen	Adam Felber & Jeanne Simpson
Becky Browder & Ted Neustadt	Connie Grappo & Lee Wilkof	Anne Meara & Jerry Stiller	Phillip K. & Gloria W. Smith
Susan Bruce & Peter Hedges	Michael Greif & Jonathan Fried	Alan & Janis Menken	Abigail Rose Solomon
Peter Jay Fernandez & Denise Burse	Mary Grieco	Chia Messina	Dr. David Solowiejczyk
Kate Burton & Michael Ritchie	Emily Grishman & Susan Sampliner	Audrey & Danny Meyer	John Steber & Robert Shaffron
Cora Cahan & Bernard Gersten	Lisa Gugenheim	Dean Michaels	James Neuberger & Helen Stambler
Mitchell Semel & Colleen Carroll	Evan Handler	Janet Mornjian & Steve Olsen	Jean Stein
Linda & Arthur Carter	Lynn Harris	Ross & Beth Moore	Ben & Christine Stiller
Rachel Chanoff	Jane & Jonathan Heine	John Morning	Abbot B. Stranahan
Ellen Chenoweth	Amy Henkels	Alfred Morris	Donald Margulies & Lynn Street
Glenda Chesshir	David Herdrich & Elizabeth Palmer Herdrich	Robin Morse & Gus Rogerson	Susanna Styron & Darrell Larson
Marissa & Travis Chibas	Peter Herdrich & Karen Trott	Patricia M. Murphy, Esq. & Adam Spilka	Daniel Swee
Richard Frankel & Kathleen Clark	Lieta Hesen-Cohen & Richard Cohn	Tony Goldwyn & Jane Musky	Mariko Tada
Jerome Cohen Congress	Nan & George Hirst	Geoffrey Nauftts	Jay & Rachel Tarses
Jace Alexander & Maddie Corman	Caroline Hon	Pam Nelson & Peter Fritschel	Mary Lou Teel & Peter Freundlich
Max Mayer & Catherine Corpeny	Michelle Hurst	Randy & Rona Nelson	Tracy Thorne & Edmund Lewis
Margaret Crimmins	Virginia & Richard Irwin	Rurth Nelson	Kevin O'Rourke & Edith Thurber
George & Cathy Crow	Sy Jacobs	Mark Nesselson, M.D. & Elliott Rosenblum	Shane Tilson-L'Estrange
Cameron Crowe	Whitney Scott & Peter Jacobson	Cynthia Nixon	Gina Torres
Stephen & Sandra Crudgington	Linda Janklow	Steven O'Neill	Anne Torsiglieri
Tom Cruise	Macon R. & Michael B. Jessop	Carol Ochs & Bruce MacVittie	Joan Vail & John Thorne
Arthur Dantchik	Tom Slaughter & Marthe Jocelyn	Jacki Ochs & Jan Kroeze	Laura Valeroso & David Seidman
Cathy Dantchik	Amanda Johns	Paul & Maria Onderdonk	Robert Abrams & Cynthia Vance
Peter and Judith Dawkins	Julia A. Johns	Greg MacPherson & Jane Perlmutter	Wendy vanden Heuvel & Brad Coley
Cameron Diaz	Andrea Johnson	Steven & Margot Peter	John A. Vassallo
Edward & Joanne DiRugeri	Traci Paige Johnson & Robert Mowen	Bat-Sheva & Thomas Peters	Borah & Mildred Walton
Jon Divis & Gene Reilly	Cherry Jones & Mary O'Connor	Peter & Ana Rosa Phillips	Anita Waxman
Richard & Rebecca Dresser	Larry & Mary Jones	Susan Ochs Phillips	Sally & Lenny Weiss
Christopher & Karen Eddowes	Maurice Kanbar	Richard Polatchek	Daniel Wiener
Mario Egozi	Lisa A. Kauffman	Jeremy Posner	Jenny Wiener
David Eigenberg	Paul McCrane & Dana Kellin	Dean & Leslie Potashner	Michael & Zena Wiener
Ned Eisenberg	Stephen Kepniss	Gigi Pritzker Pucker & Michael Pucker	Elizabeth Williams & Joseph Forte
Sophia & Gordon Elliott	Seth & Beth Klarman	Christopher Randolph	Jan Wilson & Saula Cutter
Barbara Ettinger	Joana & Jason Klot	Peter & Helen Randolph	Donald Windham
Barbara Ettinger & Sven Huseby	Mary Kong	Theresa Rebeck & Jess Lynn	Sarah Winkler & Simon Leopold
Heidi Ettinger	Belle & Roger Kuhn	Alysia Reiner & David Basche	John Woo
Wendy Ettinger & Derek McLane	Judy Kuhn & David Schwab	Lucy E. Retan	Joanne Woodward & Paul Newman
Hannah Finn & John Wiltshire	Allan & Nanette Larson	Anthony Rhulen	Jeffrey & Janine Yass
Billy Finnegan	Kate Lear & Jonathan LaPook		James & Mary Lin Yoshimura
Matt Williams & Angelina Fiordellisi			Richard Blackstone & Yldeez Yuksek
Terry Fitzpatrick & Stephen Perelopuk			Virginia Zakian & Robert Sandberg
			Stuart Zicherman

The 52nd Street Project  
presents the Fall 2001 Playmaking Series

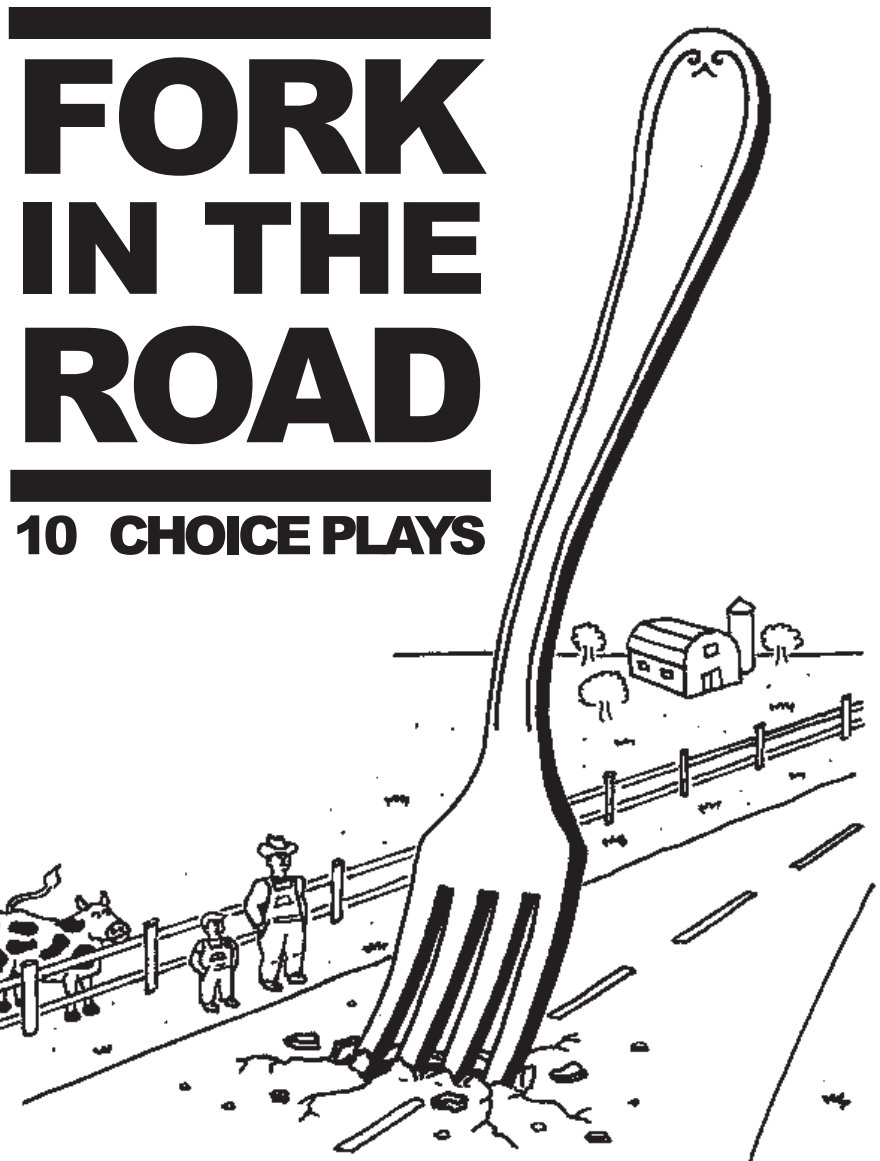

**10 CHOICE PLAYS**

Fri., Dec. 14 at 7:30 p.m., Sat., Dec. 15 at 3:00 p.m. and 7:30 p.m.  
and Sun., Dec. 16 at 3:00 p.m.

**The Ensemble Studio Theatre**

549 West 52nd St., New York City

# FORK IN THE ROAD

The Fall 2001 Playmaking Plays - Dec. 14-16, The Ensemble Studio Theatre

## The 52nd Street Project Staff:

Gus Rogerson, Artistic Director  
Carol Ochs, Executive Director  
Michael Bernard, Associate Artistic Director  
John Sheehy, Director of Development and Marketing  
George "X-Acto" Babiak, Production Manager  
Julie Feldman, Director of Education  
Megan Sandberg-Zakian, Volunteer Coordinator  
Chris Ceraso, Teen Dean  
Liz Bell, Education Assistant  
Diana Rojas, Executive Assistant  
Iris A. Brown, Graphic Designer  
Mayleen Cancel and Jayme Rosado, Receptionists  
Claire Sather, Intern



## Production Staff

**Composer:** Rusty Magee  
**Set Designer:** Kevin Joseph Roach  
**Lighting Designer:**  
Greg MacPherson  
**Costume Designer:** Janet Edwards  
**Sound Designer:**  
Betsy Rhodes  
**Stage Manager:**  
Perry McBain Daniel  
**Slide Designers:**  
Katherine Lumb, Richard Hicks,  
Monty Nicol, Kim Snow,  
John Steward, Alberta Testanero,  
Iwona Waluk  
**"Fork" Illustrations:** George Babiak  
**Prop Design Team:**  
Anju Andre-Bergmann, George  
Babiak, Heather Carnduff,  
Virginia Gifford, Jennifer Getzinger,

Cara Marcous, Natalie Musteata,  
Leigh Pennebaker, Christina  
Ramirez, Megan Sandberg-Zakian,  
Claire Sather, John Sheehy, Kurt  
Wootton  
**Furniture Crew:**  
Ritch Duncan, Shirley Rumierk,  
Johnathan Roldan  
**Prop Crew:**  
Abigail Solomon, Claire Sather,  
Frankie Ventura, Adrian Zambrano  
**Load-in and Light Hang Crew:**  
Doug Lockwood, Perry McBain  
Daniel, Betsy Rhodes, Samara  
Rifkin, Claire Sather, Tom Schall,  
Maury Schott  
**House Manager:** Maury Schott  
**Hosts:** Eric Karpeles and Mike Sell  
**Master Chef:** Eric Karpeles



NATIONAL  
ENDOWMENT  
FOR THE ARTS

The Playmaking Program is made possible with public funds from the National Endowment for the Arts; The New York State Council on the Arts, a state agency; the Department of Youth and Community Development; and the New York City Department of Cultural Affairs Cultural Challenge Program. The 52nd Street Project is a member of Art/NY and a participant in the New Generations Program, funded by Doris Duke Charitable Foundation/The Andrew W. Mellon Foundation and administered by Theatre Communications Group, the national organization for the American Theater.

State of the Arts



NYSCA

## COOL STUFF ON SALE IN THE LOBBY!

The Fabulous Flyer Bar .....\$2.00 & \$1.50  
*and featuring Shel Silverstein's "Fivey and Twoey" logo:*  
Project Sweatshirts (NEW ITEM!) .....\$20.00  
Project T-shirts, long sleeve .....\$15.00  
Project Caps (NEW design) .....\$15.00  
Project Mugs .....\$5.00  
Project Pencil 3-pack (now in RED!) .....\$1.00

Thank you for coming to **FORK IN THE ROAD**. If you are not on our mailing list (or if your address has changed), please fill out this form and give it to us on your way out or mail it to the address below. We would also like to know if you are interested in becoming a volunteer. We need help in **all areas**, so be sure to fill out the entire form.

### PLEASE ADD ME TO YOUR MAILING LIST:

12/01

NAME: \_\_\_\_\_

ADDRESS: \_\_\_\_\_

ZIP \_\_\_\_\_

HOME PHONE: \_\_\_\_\_

DAYTIME PHONE: \_\_\_\_\_

E-MAIL ADDRESS: \_\_\_\_\_

MY OCCUPATION: \_\_\_\_\_

MY HOBBIES: \_\_\_\_\_

### YES, I WOULD LIKE TO BE OF HELP. I CAN:

- |   |   |  |
|---|---|--|
| <input type="checkbox"/> Help load in and out for shows | <input type="checkbox"/> Draw and/or paint  | <input type="checkbox"/> Help kids with homework |
| <input type="checkbox"/> Hang lights                    | <input type="checkbox"/> Help with mailings | <input type="checkbox"/> Teach kids a skill      |
| <input type="checkbox"/> Work on a backstage crew       | <input type="checkbox"/> Do office work     | <input type="checkbox"/> Be a chef at an event   |
| <input type="checkbox"/> Do graphic design              | <input type="checkbox"/> Design sound       | <input type="checkbox"/> Design and sew costumes |
| <input type="checkbox"/> Other (please specify) _____   |   |  |

### MY SCHEDULE IS:

- Very flexible. I'm often available during weekdays.  
 Somewhat flexible. I can help on the occasional morning or afternoon during the week.  
 Not very flexible at all, but I've got some free time on evenings and weekends.

If you would like to mail this (and you're always welcome to enclose a tax-deductible contribution), you can send it to: **The 52nd Street Project**, 500 West 52nd St., New York, NY 10019. Or fax it to (212) 333-5598.

**Don't Miss Our Upcoming Shows!**

# Table For Two

## THE RESTAURANT PLAYS



### THE 2002 TWO-ON-TWOS

Feb. 1-3, 2002 at The Women's Interart Annex  
(Right across the hall from the Clubhouse)

In the One-on-One's, a single kid is paired with a single adult. Now you can see *two* kids perform a play written by an adult and directed by *another* adult. Call 642-5052 for reservations

# Heart of The Matter

(Basically Ten Plays)

The Winter Playmaking Series

March, 2002 at a theater to be announced.

If you're enjoying the show tonight, you'll want to come see the work of our next batch of Project newcomers! Theater to be announced.

The 52nd Street Project is a non-profit organization that brings children from the Hell's Kitchen neighborhood together with professional theater artists to create original theater. **FORK IN THE ROAD** is a production of our Playmaking program. Young people participate in an eight-week playwriting course taught by Michael Bernard and adapted for the Project by Daniel Judah Sklar from his book *Playmaking: Children Writing and Performing Their Own Plays*. At the end of the course, each child is given two actors, a theme, and a dramaturg/director who guides him or her through the writing of a play during a weekend retreat in the country (Tyler Hill, Pennsylvania, for this show). Tonight's performance is the end result.

The Project is delighted to return to the Ensemble Studio Theatre, where we have been performing since our inception in 1981. We gratefully acknowledge the fact that if E.S.T. wasn't here, we'd be nowhere.

### The 52nd Street Project Board of Directors

Ben Barenholtz	Patricia M. Murphy, Esq.
Lisa Benavides	Carol Ochs
Rachel Chanoff	Willie Reale
Heidi Ettinger	Gus Rogerson
Wendy Ettinger, <i>chair emeritus</i>	José Soto, Jr., <i>alumni boardmember</i>
Louis P. Friedman	Pamala Tyson
Stephen Graham, <i>chair</i>	Laura Valeroso
Larry Jones	Wendy vanden Heuvel
James McDaniel	Jenny Wiener
Frances McDormand	

### Special Thanks

We're extremely grateful to Eric Karpeles and Mike Sell, who graciously allowed us to use their beautiful home in Pennsylvania as our base of operations for the writer's retreat. Thanks also to our terrific host families, the Cobbs, the Grunns, the Halvorsens, the Pursches, the Russos, the Rutledges, Sohail Raikhy, and the Stoeckles.

### In-Kind Contributions

Ensemble Studio Theatre, Neil A. Mazzella and Hudson Scenic Studios, the Murphy Law Office, Iris A. Brown, Ron Kastner and Capital Printing, Au'Some Candies, Big Apple Lights, Coleman, The Gap, Noggin, The Printing Store, Scholastic, Inc., Seagram's Chateau & Estate Wines, Shapiro & Lobel, Sesame Workshop, Watkins, Inc., Mayor's Office of Film & Television, Boylan's Bottling Co., David Sneddon & Fairway Market, Women's Interart, Andy Millon, Steve Olsen & The Westbank Cafe, Imaginary Studios, Robert Goldberg and Yorke Construction, Prime Films, and Cubic B's.

## FORK IN THE ROAD - ACT I

All original music composed by Rusty Magee

### A So-Called Family

By Michael Velez, age 11. Dramaturg/Director: Rick Meese

Joseph .....David Zayas  
Jasmine .....Larry Nathanson  
Crazy the Monkey .....Michael Bernard  
Baby voices .....Ritch Duncan

“One Time Ago” lyrics by Michael Velez. Choreography by Jeanne Simpson.

### Step By Step

by Madelyne Ross, age 12. Dramaturg/Director: Jessica Bauman

Keisha .....Lizzy Davis  
Mr. Williams .....Michael Potts  
Principal .....Kevin Jackson  
Students .....Frankie Ventura and Adrian Zambrano

### Ruby and Buddy’s Big Deal: Be Yourself

by Alex Tomas, age 11. Dramaturg/Director: Angel David

Ruby .....Zabryna Guevara  
Buddy .....Ray Thomas  
Mr. James .....Ritch Duncan  
A Waiter .....Abigail Solomon

“Be Yourself” lyrics by Alex Tomas.

### The Crystal Hunt

by Victor Ariel Cortes, age 9. Dramaturg/Director: Sascha Paladino

Zack .....David Eigenberg  
Ricky .....David Costabile  
Slime People .....Crew

### A Date For Mom

by Johanna Vidal, age 11. Dramaturg/Director: George Babiak

Angie .....Niambi Nataka  
Mom .....Phyllis Somerville  
Jimmy .....Christopher Randolph  
Man in Store .....Lee Wilkof  
Cops .....Frankie Ventura and Adrian Zambrano

👉 **Intermission!** 👈

## FORK IN THE ROAD - ACT II

### To Sing Or Not To Sing

by Solangee Acosta, age 12. Dramaturg/Director: Lizzie Gottlieb

Stephanie .....Judy Kuhn  
Nancy Babushka .....Lois Smith  
Sam .....Frankie Ventura  
Burger King Patrons .....Johnathan Roldan and Adrian Zambrano  
Steve .....John Sheehy

“Emotions” and “Money” lyrics by Solangee Acosta.

### Sneezing Andrea

by Katie Grullon, age 11. Dramaturg/Director: Kay Matschullat

Andrea .....Abigail Lopez  
Sasha .....Leslie Lyles

### One Night at the Heavenly Hotel

By Lilli Cooper, age 11. Dramaturg/Director: Susan Vitucci

Shannon .....Mercedes Herrero  
Lisa .....Phyllis Somerville  
Mrs. Perry .....Shirley Rumierk

“What People Think When They’re Alone” lyrics by Lilli Cooper

### Jack and Jill

by Zebulun Santiago, age 11. Dramaturg/Director: Glynis Rigby

Jack .....Phillip Christian  
Jill .....Anita Flanagan  
Preacher .....Shirley Rumierk

### A Classroom Breakout

by Spencer Lopez, age 11. Dramaturg/Director: Lee Wilkof

Jhon .....Billy Crudup  
Mr. Lowell .....Kevin Jackson  
Dad .....Lee Wilkof  
Announcer .....Michael Bernard

“Friendship” lyrics by Spencer Lopez



The 52nd Street Project gratefully acknowledges the support of the following foundations and corporations: Barker Welfare Foundation, The Barnsley Foundation, Capital Research Company, Carnegie Corporation of New York, Comedy Central, Deutsche Bank of Americas Foundation, The Dramatists Guild Fund, Dramatists Play Service, Eleanor, Adam & Mel Dubin Foundation, Doris Duke Charitable Foundation, Entertainment Weekly, The Fan Fox & Leslie R. Samuels Foundation, The J. Paul Getty Trust, The Horace W. Goldsmith Foundation, The Hennessy Foundation, Holland Lodge Foundation, Hudson Scenic Studio, Betty E. & George B. Kaiser Foundation, Lloyds TSB Bank plc, James A. Macdonald Foundation, Helen Merrill, Ltd., Milbrook School, The Cynthia & George Mitchell Foundation, The William Morris Agency, Mosaic Entertainment, The National Board of Review, The New World Foundation, The New York Times Company Foundation, Newman's Own, Paramount Pictures, Laura Pels Foundation, Roulette Entertainment, Staging & Design, Inc., Harold & Mimi Steinberg Charitable Trust, The Surdna Foundation, Susquehanna, Theatre Communications Group, Inc., John A. Vassilaros & Son, Inc., The Vervane Foundation, West Bank Cafe, The Wiener Family Foundation, Yorke Construction Corporation In addition the following individuals made gifts of over \$150 this year (list is current as of 1/30/02)

Anonymous	Hannah Finn & John Wiltshire	Judy Kuhn & David Schwab	David & Anita Rogerson
Liliana Amador-Marty & Frank Marty	Billy Finnegan	Roger & Belle Kuhn	Clifford & Betsy Ross
Drew McCoy & Amy Aquino	Matt Williams & Angelina Fiordellisi	Lynn Landis	Daryl Roth
Mary Bacon & Andrew Leynse	Terry Fitzpatrick & Stephen Perrepeluk	Allan & Nanette Larson	Alexander Roy
June Ballinger & Michael Goldstein	Alexa Fogel	Kate Lear & Jonathan LaPook	Shirley Rumierk
Talia Balsam & John Slattery	Katherine Foster	Courtney LeClaire-Conway	Steve Sabba
Ben Barenholtz	David Frankel	Willem Dafoe & Liz Lecompte	Laura Sametz
Benny Bartley	Eric & Juli Frankel	Becky & Steven Lewis	Tim & Lisa Sanford
Jessica Bauman	Naomi Freundlich & Charles Miles	James Waterston & Line Lillevik	Karin & Tom Schall
Laurie Becker & Rick Sweren	Louis & Patrice Friedman	Margo Lion	Beth Schneider
Meredith Beeuwkes	Victor Garber	Jessica Lissy	Mauzy Scott
Gregory Bello	Beth Gardiner	Adrienne Lobel & Mark Linn Baker	Whitney Scott & Peter Jacobson
Lisa Benavides & Tim Nelson	Jeanne Garofalo	Richard & Susan Lobel	Stefan Selig
Barry & Myrna Bernard	Rose Gasner & Larry Chertoff	Charles Loutrell	Jeffrey Seller & Joshua Lehrer
Brian Swardstrom & Bonnie Bernstein	Jonathan Gazdak	John Lyons	Alyson Shapero
Alexander & Elizabeth Bernstein	Alexandra Gersten & John Vassilaros	Grace Lyu-VolckHausen	Aaron & Elaine Shapiro
Stephen Bernstein	Willie Reale & Jenny Gersten	Marsue & Peter MacNicol	Jonathan Sheffer
Vicky Bijur & Ed Levine	Jilian Cahan Gersten	Paul & Lauren Mandell	William Holtzman & S. Sylvia Shepard
Lewis Black	Ileen Getz & Mark Grinnell	Elizabeth Manne	Reed Birney & Connie Shulman
Tessa Blake	Nancy Giles	Peter Manning & André Bishop	Meg Simon
Mitchell Lemsky & Jane Bodle	Lloyd & Kilty Gilmour	Richard Marin	Abigail Rose Solomon
Jane Bolster & Steve Wertimer	Bob Glennon	Ali Marsh	Dr. David Solowiejczyk
Buzz Bovshow	Judy Goldman & Michael Pillingier	Jesse L. Martin	José & Michelle Soto
Alan Braverman	Fred & Nancy Goodman	Dave & Alicia Matthews	James Neuberger & Helen Stambler
Kathy Briggs	Stephen & Cathy Graham	Paul Reale & Barbara McCrane	Fran McDormand & Joel Coen
Becky Browder & Ted Neustadt	Connie Grappo & Lee Wilkof	James & Hannelore McDaniel	Anne Meara & Jerry Stiller
Susan Bruce & Peter Hedges	Michael Greif & Jonathan Fried	Dean Michaels	Alan & Janis Menken
Peter Jay Fernandez & Denise Burse	Emily Grishman & Susan Sampliner	Ross & Beth Moore	Chia Messina
Kate Burton & Michael Ritchie	Lisa Gugenheim	John Morning	Audrey & Danny Meyer
Cora Cahan & Bernard Gersten	Evan Handler	Alfred H. Morris	Nancy Meyer & Marc Weiss
Mitchell Semel & Colleen Carroll	Lynn E. Harris	Robin Morse & Gus Rogerson	Kevin O'Rourke & Edith Thurber
Linda & Arthur Carter	Jane & Jonathan Heine	Patricia M. Murphy, Esq. & Adam Spilka	Gina Torres
Rachel Chanoff	Amy Henkels	Timothy Murtha & Elizabeth McDermott	Anne Torsiglieri & Michael Bernard
Ellen Chenoweth	David Herdrich & Elizabeth Palmer Herdrich	Tony Goldwyn & Jane Musky	Peter Herdrich & Karen Trott
Glenda Chesshir	Lieta Hesen-Cohen & Richard Cohn	Geoffrey Nauffts	Pamala Tyson & Sean Mudd
Marissa & Travis Chibas	Katy Homans & Patterson Sims	Pamela & Peter Nelson	Joan Vail & John Thorne
Richard Frankel & Kathleen Clark	Caroline Hon	Ruth Nelson	Laura Valeroso & David Seidman
Jerome Cohen Congress	Kate Hudson & Chris Robinson	Mark Nesselson, M.D. & Elliott Rosenblum	Robert Abrams & Cynthia Vance
Elizabeth Cooper-Davis & Gordon Davis	Michelle Hurst	Steven O'Neill	Wendy vanden Heuvel & Brad Coley
Jace Alexander & Maddie Corman	Virginia & Richard Irwin	Carol Ochs & Bruce MacVittie	John A. Vassallo
Margaret Crimmins	Sy Jacobs	Jacki Ochs & Jan Kroeze	Borah & Mildred Walton
Bill Wrubel & Jennifer Crittenden	Linda Janklow	Paul & Maria Onderdonk	Anita Waxman
George & Cathy Crow	Macon R. & Michael B. Jessop	Greg MacPherson & Jane Perlmutter	Sally & Lenny Weiss
Cameron Crowe	Amanda Johns	Steven & Margot Peter	Daniel Wiener
Tom Cruise	Julia A. Johns	Bat-Sheva & Thomas Peters	Jenny Wiener
Arthur Dantchik	Andrea Johnson	Peter & Ana Rosa Phillips	Michael & Zena Wiener
Cathy Dantchik	Traci Paige Johnson & Robert Mowen	Susan Ochs Phillips	Elizabeth Williams & Joseph Forte
Peter & Judith Dawkins	Cherry Jones & Mary O'Connor	Jeremy Posner	Jan Wilson & Saula Cutter
Noël Dawkins	Larry & Mary Jones	Dean & Leslie Potashner	Donald Windham
Cameron Diaz	Maurice Kanbar	Christopher Randolph	Gary Winick
Buddy Dikman & Chuck Davis	Lisa A. Kauffman	Peter & Helen Randolph	Sarah Winkler & Simon Leopold
Edward & Joanne DiRugieris	Paul McCrane & Dana Kellin	Alysia Reiner & David Basche	John Woo
Jon Divis & Gene Reilly	Stephen & Sharon Kepniss	Lucy E. Retan	Joanne Woodward & Paul Newman
Richard & Rebecca Dresser	Seth & Beth Klarman	Loree Rodkin	Jeffrey & Janine Yass
Mario Egozi	Joana & Jason Kliot		James & Mary Lin Yoshimura
Ned Eisenberg	Mary Kong		Richard Blackstone & Yildez Yuksek
Sophia & Gordon Elliott			Virginia Zakian & Robert Sandberg
Barbara Ettinger & Sven Huseby			Stuart Zicherman
Wendy Ettinger & Derek McLane			

*The 52nd Street Project Presents*

# TABLE FOR TWO

## THE RESTAURANT PLAYS



## The 2002 Two-on-Two's

*Friday, February 1 at 7:30 p.m.*

*Saturday, February 2 at 3:00 & 7:30 p.m.*

*Sunday, February 3 at 3:00 p.m.*

*The Women's Interart Annex*

*500 W. 52nd St., #2A (2nd Floor)*



*The 2002 Two-on-Twos*  
**Table for Two: The Restaurant Plays**  
*The Women's Interart Annex - Feb. 1-3, 2002*

**The 52nd Street Project Staff:**

Gus Rogerson, Artistic Director  
 Carol Ochs, Executive Director  
 Michael Bernard, Associate Artistic Director  
 John Sheehy, Director of Development and Marketing  
 George "X-Acto" Babiak, Production Manager  
 Julie Feldman, Director of Education  
 Megan Sandberg-Zakian, Volunteer Coordinator  
 Chris Ceraso, Teen Dean  
 Liz Bell, Education Assistant  
 Diana "The Kid" Rojas, Executive Assistant  
 Iris A. Brown, Graphic Designer  
 Mayleen Cancel and Jayme Rosado, Receptionists  
 Catherine Glenn, Britta Jensen, Julia Walk Miller, Interns



**Composer:**

Deborah Abramson

**Music Director:**

Joe Rubenstein

**Set Designer:**

Kevin Joseph Roach

**Lighting Designer:**

Greg MacPherson

**Costume Designer:**

Melissa Toth

**Sound Designer:** Britta Jensen

**Stage Manager:**

Dawn Reynolds

**Slide Designers:**

Katherine Lumb, Richard Hicks,  
 Monty Nicol, Kim Snow, Iwona  
 Waluk, and George Babiak

**"Table for Two" Illustration:**

Chesley McLaren

**Prop Design Team:**

George Babiak, Heather Carnduff,  
 Catherine Glenn, Britta Jensen,  
 Annette Madden, Cara Marcous,  
 Julia Walk Miller, Jay Patterson,  
 Leigh Pennebaker, Diana Rojas

**Furniture Crew:**

Kevin Heisler

**Prop Crew:**

Julia Walk Miller, Catherine Glenn,  
 Judy Agosto, Ivana Granados

**Load-in and Light Hang Crew:**

Dale Ho, Frauke Levin, Anna Li,  
 Jay Patterson, Becky White

**House Manager:** Maury Schott

**Host and Guest Chef:**

Maria Tucci

**Master Chefs:**

Carol Ochs & John Sheehy



NATIONAL  
 ENDOWMENT  
 FOR THE ARTS

The Two-on-Two Program is made possible with public funds from the National Endowment for the Arts; The New York State Council on the Arts, a state agency; the Department of Youth and Community Development; and the New York City Department of Cultural Affairs. The 52nd Street Project is a member of Art/NY.

State of the Arts



**COOL STUFF ON SALE IN THE LOBBY!**

The Fabulous Flyer Bar .....\$2.00 & \$1.50  
*and featuring Shel Silverstein's "Fivey and Twoey" logo:*  
 Project Sweatshirts (NEW ITEM!) .....\$20.00  
 Project T-shirts, long sleeve .....\$15.00  
 Project Caps (NEW design) .....\$15.00  
 Project Mugs .....\$5.00  
 Project Pencil 3-pack (now in RED!) .....\$1.00

Thank you for coming to **TABLE FOR TWO!** If you are not on our mailing list (or if your address has changed), please fill out this form and give it to us on your way out or mail it to the address below. We would also like to know if you are interested in becoming a volunteer. We need help in *all areas*, so be sure to fill out the entire form.

**PLEASE ADD ME TO YOUR MAILING LIST:**

1/02

NAME: \_\_\_\_\_

ADDRESS: \_\_\_\_\_

ZIP

HOME PHONE: \_\_\_\_\_

DAYTIME PHONE: \_\_\_\_\_

E-MAIL ADDRESS: \_\_\_\_\_

MY OCCUPATION: \_\_\_\_\_

MY HOBBIES: \_\_\_\_\_

**YES, I WOULD LIKE TO BE OF HELP. I CAN:**

- |   |   |  |
|---|---|--|
| <input type="checkbox"/> Help load in and out for shows | <input type="checkbox"/> Draw and/or paint  | <input type="checkbox"/> Help kids with homework |
| <input type="checkbox"/> Hang lights                    | <input type="checkbox"/> Help with mailings | <input type="checkbox"/> Teach kids a skill      |
| <input type="checkbox"/> Work on a backstage crew       | <input type="checkbox"/> Do office work     | <input type="checkbox"/> Be a chef at an event   |
| <input type="checkbox"/> Do graphic design              | <input type="checkbox"/> Design sound       | <input type="checkbox"/> Design and sew costumes |
| <input type="checkbox"/> Other (please specify) _____   |   |  |

**MY SCHEDULE IS:**

- Very flexible. I'm often available during weekdays.  
 Somewhat flexible. I can help on the occasional morning or afternoon during the week.  
 Not very flexible at all, but I've got some free time on evenings and weekends.

If you would like to mail this (and you're always welcome to enclose a tax-deductible contribution), you can send it to: **The 52nd Street Project**, 500 West 52nd St., New York, NY 10019. Or fax it to (212) 333-5598.

## Don't Miss Our Upcoming Shows!

# Heart of The Matter (Basically Ten Plays)

The Winter Playmaking Series

**March 22-24 at a theater to be announced.**

This month, a fresh batch of newcomers began our 8-week Playmaking program. At the end of the class they will be whisked away to Kent, Connecticut for a weekend in which they will fashion 10 brand new plays featuring your favorite Project adult actors.

**Honorary Chairman Tom Cruise invites you to  
SAVE THE DATE & THE LAST DANCE**

**MONDAY,  
MAY 13, 2002**

**STILL  
STAYIN'  
ALIVE**



**The 52nd Street Project's 20th Anniversary**

**DISCO BENEFIT**

For more information or reservations call John "Dancin' Machine" Sheehy  
@ 212/333-5252.

The 52nd Street Project is a non-profit organization that brings children from the Hell's Kitchen neighborhood together with professional theater artists to create original theater. **Table for Two** is a production of our Two-on-Two program, in which two of the Project's more seasoned kids are matched with two adult volunteers (one playwright, one director) and given the task of creating a short play. After the writers presented their contributions, the actors and directors traveled to Dutchess County earlier this month to rehearse the plays over a three-day weekend. Tonight's performance is the final result.

### The 52nd Street Project Board of Directors

Ben Barenholtz

Lisa Benavides

Rachel Chanoff

Cathy Dantchik

Noël Dawkins

Wendy Ettinger,

*chair emeritus*

Louis P. Friedman

Stephen Graham,

*chair*

Larry Jones

James McDaniel

Frances McDormand

Patricia M. Murphy, Esq.

Carol Ochs

Willie Reale

Shirley Rumierk,

*alumni boardmember*

Gus Rogerson

José Soto, Jr.,

*alumni boardmember*

Pamala Tyson

Laura Valeroso

Wendy vanden Heuvel

John A. Vassilaros

Jenny Wiener

### Special Thanks

We're grateful to **Margot, Ronnie, Paul, Sonya**, and the rest of the staff at **Women's Interart Annex** for making their extremely convenient space available to us. We also owe big-time to **Maria Tucci** and **Robert Gottlieb**, **Stephen Perpeluk** and **Terry Fitzpatrick**, and **Derek McLane** and **Wendy Ettinger**, all of whom graciously allowed us to use their upstate homes for three tumultuous and fun-filled days. Our gratitude also goes to Super Project Pal **Ron Fiorina** of **Boylan Bottling Co.**, **Mary Moore** and **D'Agostino's Supermarkets**, and brand-spanking new board member **John A. Vassilaros** (a.k.a. Johnny Coffeeshopolis) for contributing our intermission refreshments.

## Table for Two: The Restaurant Plays - Act One

All original music composed by Deborah Abramson  
and performed by Joe Rubenstein

### Crazy Larry's Squid Hut

By Susan Kim. Directed by Joel de la Fuente.

Crazy Larry ..... Adalberto Rodriguez  
Dolores/Jessica ..... Wendy Rivera

"I Want a Restaurant" lyrics by John Sheehy.

### The King Ain't the Thing

by Jerome Hairston. Directed by Gus Rogerson.

King Diggity ..... Oscar Padilla  
Brotha Bubba ..... Akeem Frazier  
Mister Ed ..... Ed Vassallo  
Groupies ..... The crew

"The King Ain't the Thing" and "I'm Gonna Chomp the Chump"  
lyrics by Jerome Hairston.

### Hungry for Heaven

By Alexandra Gersten. Directed by Megan Sandberg-Zakian.

Angela ..... Kathy Taveras  
Cherie ..... Lizette Natera  
Maria Coffeeshopolis ..... Diana Rojas  
Little Roach ..... Judy Agosto  
Roach Chorus ..... Ivana Granados, John Sheehy,  
and Nancy Giles

"It Is a Pleasure to Serve" lyrics by Willie Reale.

 **Intermission!** 

Root Beer Floats, Coffee,  
and Flyer Bars in the lobby!

## Act Two

### The Luckiest Men in the World

By Michaela Murphy. Directed by Ed Vassallo.

Lou Gehrig ..... Frankie Ventura  
Babe Ruth ..... Adrian Zambrano  
Announcer ..... Ed Vassallo  
Patron ..... Ed Vassallo

"Step Up to the Plate" lyrics by Michaela Murphy.

### The Right Place

by John Sheehy. Directed by Nancy Giles.

Tamara ..... Allary Seda  
Crystal ..... Tiffany Butler

"The Right Place" lyrics by John Sheehy.

### Short-Order Crook

By Adam Felber. Directed by Jeanne Simpson.

Lenny Knuckles ..... Jeremy Butler  
Margaret ..... Jaymaree Rosado  
The Police ..... Jeanne Simpson, Adam Felber

"You Grabbed a Fork" lyrics by Adam Felber.



The 52nd Street Project gratefully acknowledges the support of the following foundations and corporations: Barker Welfare Foundation, The Barnsley Foundation, Capital Research Company, Carnegie Corporation of New York, Comedy Central, Deutsche Bank of Americas Foundation, The Dramatists Guild Fund, Dramatists Play Service, Eleanor, Adam & Mel Dubin Foundation, Doris Duke Charitable Foundation, Entertainment Weekly, The Fan Fox & Leslie R. Samuels Foundation, The J. Paul Getty Trust, The Horace W. Goldsmith Foundation, The Hennessy Foundation, Holland Lodge Foundation, Hudson Scenic Studio, Betty E. & George B. Kaiser Foundation, Lloyds TSB Bank plc, Lucent Technologies, James A. Macdonald Foundation, The Andrew W. Mellon Foundation, Helen Merrill, Ltd., Milbrook School, The Cynthia & George Mitchell Foundation, The William Morris Agency, Mosaic Entertainment, The National Board of Review, The New World Foundation, The New York Times Company Foundation, Newman's Own, Paramount Pictures, Laura Pels Foundation, Roulette Entertainment, Staging & Design, Inc., Harold & Mimi Steinberg Charitable Trust, The Sordna Foundation, Susquehanna, Tiger Baron Foundation, Theatre Communications Group, Inc., John A. Vassilaros & Son, Inc., The Vervane Foundation, West Bank Cafe, The Wiener Family Foundation, Yorke Construction Corporation. In addition the following individuals made gifts of over \$150 this year (list is current as of 3/21/02)

Anonymous	Hannah Finn & John Wiltshire	Judy Kuhn & David Schwab	David & Anita Rogerson
Liliana Amador-Marty & Frank Marty	Billy Finnegan	Roger & Belle Kuhn	Clifford & Betsy Ross
Drew McCoy & Amy Aquino	Matt Williams & Angelina Fiordellisi	Lynn Landis	Daryl Roth
Mary Bacon & Andrew Leynse	Terry Fitzpatrick & Stephen Perrepelek	Allan & Nanette Larson	Alexander Roy
June Ballinger & Michael Goldstein	Alexa Fogel	Kate Lear & Jonathan LaPook	Shirley Rumierk
Talia Balsam & John Slattery	Katherine Foster	Courtney LeClaire-Conway	Steve Sabba
Ben Barenholtz	David Frankel	Willem Dafoe & Liz Lecompte	Laura Sametz
Benny Bartley	Eric & Juli Frankel	Becky & Steven Lewis	Tim & Lisa Sanford
Jessica Bauman	Naomi Freundlich & Charles Miles	James Waterston & Line Lillevik	Karin & Tom Schall
Laurie Becker & Rick Sweren	Louis & Patrice Friedman	Margo Lion	Beth Schneider
Meredith Beeuwkes	Victor Garber	Jessica Lissy	Maury Schott
Gregory Bello	Beth Gardiner	Adrienne Lobel & Mark Linn Baker	Whitney Scott & Peter Jacobson
Lisa Benavides & Tim Nelson	Jeananne Garofalo	Richard & Susan Lobel	Stefan Selig
Barry & Myrna Bernard	Rose Gasner & Larry Chertoff	Charles Loutrell	Jeffrey Sellar & Joshua Lehrer
Brian Swardstrom & Bonnie Bernstein	Jonathan Gazdak	John Lyons	Alyson Shapero
Alexander & Elizabeth Bernstein	Alexandra Gersten & John Vassilaros	Grace Lyu-VolckHausen	Aaron & Elaine Shapiro
Stephen Bernstein	Willie Reale & Jenny Gersten	Marsue & Peter MacNicol	Jonathan Sheffer
Vicky Bijur & Ed Levine	Jilian Cahan Gersten	Paul & Lauren Mandell	William Holtzman & S. Sylvia Shepard
Lewis Black	Ileen Getz & Mark Grinnell	Elizabeth Manne	Reed Birney & Connie Shulman
Tessa Blake	Nancy Giles	Peter Manning & André Bishop	Meg Simon
Mitchell Lemsky & Jane Bodle	Lloyd & Kilty Gilmour	Richard Marin	Abigail Rose Solomon
Jane Bolster & Steve Wertimer	Bob Glennon	Ali Marsh	Jesse L. Martin
Buzz Bovshow	Judy Goldman & Michael Pillingier	Jesse L. Martin	Dave & Alicia Matthews
Alan Braverman	Fred & Nancy Goodman	Dave & Alicia Matthews	Paul Reale & Barbara McCrane
Kathy Briggs	Stephen & Cathy Graham	James & Hannelore McDaniel	James & Hannelore McDaniel
Becky Browder & Ted Neustadt	Connie Grappo & Lee Wilkof	Fran McDormand & Joel Coen	Fran McDormand & Joel Coen
Susan Bruce & Peter Hedges	Michael Greif & Jonathan Fried	Anne Meara & Jerry Stiller	Anne Meara & Jerry Stiller
Peter Jay Fernandez & Denise Burse	Mary Grieco	Alan & Janis Menken	Alan & Janis Menken
Kate Burton & Michael Ritchie	Emily Grishman & Susan Sampliner	Chia Messina	Chia Messina
Cora Cahan & Bernard Gersten	Lisa Gugenheim	Audrey & Danny Meyer	Audrey & Danny Meyer
Mitchell Semel & Colleen Carroll	Evan Handler	Nancy Meyer & Marc Weiss	Nancy Meyer & Marc Weiss
Linda & Arthur Carter	Lynn E. Harris	Dean Michaels	Dean Michaels
Rachel Chanoff	Jane & Jonathan Heine	Ross & Beth Moore	Ross & Beth Moore
Ellen Chenoweth	Amy Henkels	John Morning	John Morning
Glenda Chesshir	David Herdrich & Elizabeth Palmer Herdrich	Alfred H. Morris	Alfred H. Morris
Marissa Chibas & Travis Preston	Lieta Hesen-Cohen & Richard Cohn	Robin Morse & Gus Rogerson	Robin Morse & Gus Rogerson
Richard Frankel & Kathleen Clark	Katy Homans & Patterson Sims	Patricia M. Murphy, Esq. & Adam Spilka	Patricia M. Murphy, Esq. & Adam Spilka
Jerome Cohen Congress	Caroline Hon	Timothy Murtha & Elizabeth McDermott	Timothy Murtha & Elizabeth McDermott
Elizabeth Cooper-Davis & Gordon Davis	Kate Hudson & Chris Robinson	Tony Goldwyn & Jane Musky	Tony Goldwyn & Jane Musky
Jace Alexander & Maddie Corman	Michelle Hurst	Geoffrey Nauffts	Geoffrey Nauffts
Margaret Crimmins	Virginia & Richard Irwin	Pamela & Peter Nelson	Pamela & Peter Nelson
Bill Wrubel & Jennifer Crittenden	Sy Jacobs	Ruth Nelson	Ruth Nelson
George & Cathy Crow	Linda Janklow	Mark Nesselson, M.D. & Elliott Rosenblum	Mark Nesselson, M.D. & Elliott Rosenblum
Cameron Crowe	Macon R. & Michael B. Jessop	Steven O'Neill	Steven O'Neill
Tom Cruise	Amanda Johns	Carol Ochs & Bruce MacVittie	Carol Ochs & Bruce MacVittie
Arthur Dantchik	Julia A. Johns	Jacki Ochs & Jan Kroeze	Jacki Ochs & Jan Kroeze
Cathy Dantchik	Andrea Johnson	Paul & Maria Onderdonk	Paul & Maria Onderdonk
Peter & Judith Dawkins	Traci Paige Johnson & Robert Mowen	Greg MacPherson & Jane Perlmutter	Greg MacPherson & Jane Perlmutter
Noël Dawkins	Cherry Jones & Mary O'Connor	Jeremy Posner	Jeremy Posner
Cameron Diaz	Larry & Mary Jones	Dean & Leslie Potashner	Dean & Leslie Potashner
Buddy Dikman & Chuck Davis	Maurice Kanbar	Christopher Randolph	Christopher Randolph
Edward & Joanne DiRuggeris	Lisa A. Kauffman	Peter & Helen Randolph	Peter & Helen Randolph
Jon Divis & Gene Reilly	Paul McCrane & Dana Kellin	Alysia Reiner & David Basche	Alysia Reiner & David Basche
Richard & Rebecca Dresser	Stephen & Sharon Kepniss	Lucy E. Retan	Lucy E. Retan
Mario Egozi	Seth & Beth Klarman	Loree Rodkin	Loree Rodkin
Ned Eisenberg	Joana & Jason Klit		
Sophia & Gordon Elliott	Mary Kong		
Heidi Ettinger			
Barbara Ettinger & Sven Huseby			
Wendy Ettinger & Derek McLane			

## The 52nd Street Project presents the Winter 2002 Playmaking Production

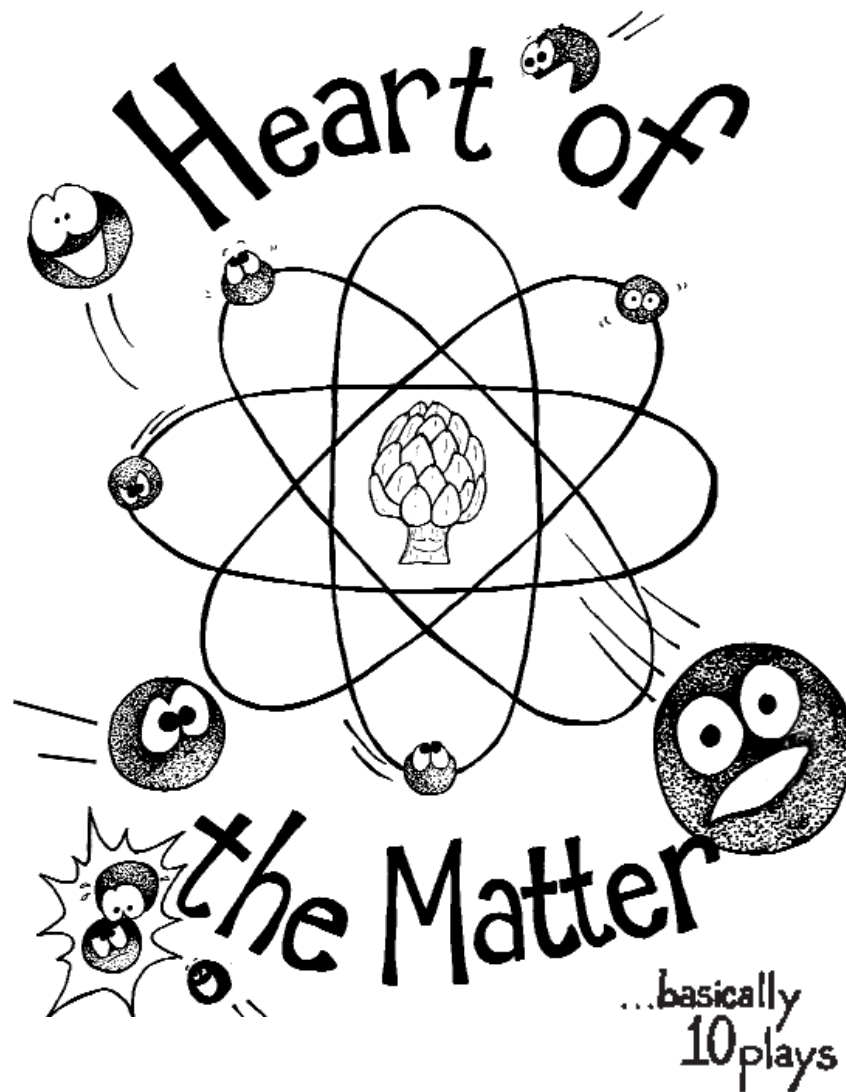

Fri., Mar., 22 at 7:30 p.m., Sat., Mar. 23 at 3:00 p.m. and 7:30 p.m.  
and Sun., Mar. 24 at 3:00 p.m.

**Theater at St. Clement's**  
423 West 46th St., New York City

# Heart of the Matter

The Winter 2002 Playmaking Plays: Mar. 22-24, Theater at St. Clement's

## The 52nd Street Project Staff:

Gus Rogerson, Artistic Director  
 Carol Ochs, Executive Director  
 Michael Bernard, Associate Artistic Director/Playmaking Director  
 John Sheehy, Director of Development and Marketing  
 George "X-Acto" Babiak, Production Manager  
 Julie Feldman, Director of Education  
 Megan Sandberg-Zakian, Volunteer Coordinator  
 Chris Ceraso, Teen Dean  
 Liz Bell, Education Assistant  
 Diana Rojas, Executive Assistant  
 Iris A. Brown, Graphic Designer  
 Mayleen Cancel and Jayme Rosado, Receptionists  
 Britta Jensen, Catherine Glenn, and Julia Walk Miller, Interns



## Production Staff

**Composer:** Rusty Magee  
**Set Designer:** Kevin Joseph Roach  
**Lighting Designer:** Greg MacPherson  
**Costume Designer:** Crystal Thompson  
**Costume Assistant:** Remy Pearce  
**Sound Designer:** Roger Raines  
**Stage Manager:** Karen Munkel  
**Slide Designers:**  
 Katherine Lumb, Richard Hicks,  
 Monty Nicol, Kim Snow,  
 John Steward, Alberta Testanero,  
 Iwona Waluk, George Babiak

## "Heart" Illustrations:

Heather Carnduff-Gobée

## Prop Design Team:

George Babiak, Liz Bell,  
 Catherine Glenn, Britta Jensen, Amy  
 Johnston, Cara Marcous, Julia Walk  
 Miller, Karen Munkel, John Sheehy

## Furniture Crew:

Britta Jensen, Osage Lewis-Ashley,  
 Joel Lind, Steven Vasquez

## Prop Crew:

Julia Walk Miller, Julie Gold,  
 Ivana Granados

## Wall Props:

## Load-in and Light Hang Crew:

Mona Arriola, Britta Jensen,  
 Moira MacDonald, Julia Walk Miller,  
 Karen Munkel, Chris Ryan,  
 John Salzman, Jason Wells,  
 Alistair Wandesforde-Smith

## House Managers:

Mary Pat Walsh, Susan McGinnis

## Hosts:

Stephen and Kathy Graham,  
 Sam and Lynn Waterston,  
 Liz and Paul Giamatti



NATIONAL  
ENDOWMENT  
FOR THE ARTS

The Playmaking Program is made possible with public funds from the National Endowment for the Arts; The New York State Council on the Arts, a state agency; the Department of Youth and Community Development; and the New York City Department of Cultural Affairs. The 52nd Street Project is a member of Art/NY and a participant in the New Generations Program, funded by Doris Duke Charitable Foundation/The Andrew W. Mellon Foundation and administered by Theatre Communications Group, the national organization for the American Theater.

State of the Arts



NYSCA

## COOL STUFF ON SALE IN THE LOBBY!

The Fabulous Flyer Bar . . . . . \$2.00 & \$1.50  
*and featuring Shel Silverstein's "Fivey and Twoey" logo:*  
 Project Sweatshirts (NEW ITEM!) . . . . \$20.00  
 Project T-shirts, long sleeve . . . . . \$15.00  
 Project Caps (NEW design) . . . . . \$15.00  
 Project Mugs . . . . . \$5.00  
 Project Pencil 3-pack (now in RED!) . . . . \$1.00

Thank you for coming to **HEART OF THE MATTER**. If you are not on our mailing list (or if your address has changed), please fill out this form and give it to us on your way out or mail it to the address below. We would also like to know if you are interested in becoming a volunteer. We need help in **all areas**, so be sure to fill out the entire form.

### PLEASE ADD ME TO YOUR MAILING LIST:

03/02

NAME: \_\_\_\_\_

ADDRESS: \_\_\_\_\_

ZIP \_\_\_\_\_

HOME PHONE: \_\_\_\_\_

DAYTIME PHONE: \_\_\_\_\_

E-MAIL ADDRESS: \_\_\_\_\_

MY OCCUPATION: \_\_\_\_\_

MY HOBBIES: \_\_\_\_\_

### YES, I WOULD LIKE TO BE OF HELP. I CAN:

- |   |   |  |
|---|---|--|
| <input type="checkbox"/> Help load in and out for shows | <input type="checkbox"/> Draw and/or paint  | <input type="checkbox"/> Help kids with homework |
| <input type="checkbox"/> Hang lights                    | <input type="checkbox"/> Help with mailings | <input type="checkbox"/> Teach kids a skill      |
| <input type="checkbox"/> Work on a backstage crew       | <input type="checkbox"/> Do office work     | <input type="checkbox"/> Be a chef at an event   |
| <input type="checkbox"/> Do graphic design              | <input type="checkbox"/> Design sound       | <input type="checkbox"/> Design and sew costumes |
| <input type="checkbox"/> Other (please specify) _____   |   |  |

### MY SCHEDULE IS:

- Very flexible. I'm often available during weekdays.  
 Somewhat flexible. I can help on the occasional morning or afternoon during the week.  
 Not very flexible at all, but I've got some free time on evenings and weekends.

If you would like to mail this (and you're always welcome to enclose a tax-deductible contribution), you can send it to: **The 52nd Street Project**, 500 West 52nd St., New York, NY 10019. Or fax it to (212) 333-5598.

**Honorary Chairman Tom Cruise  
invites you to  
SAVE THE DATE & THE LAST DANCE  
MONDAY, MAY 13, 2002**



**STILL STAYIN' ALIVE**

**The 52nd Street Project's 20th Anniversary**

**DISCO BENEFIT**

**For information, call  
John "Dancin' Machine" Sheehy  
at (212) 333-5252**

The 52nd Street Project is a non-profit organization that brings children from the Hell's Kitchen neighborhood together with professional theater artists to create original theater. **HEART OF THE MATTER** is a production of our Playmaking program. Young people participate in an eight-week playwriting course taught by Michael Bernard and adapted for the Project by Daniel Judah Sklar from his book *Playmaking: Children Writing and Performing Their Own Plays*. At the end of the course, each child is given two actors, a theme, and a dramaturg/director who guides him or her through the writing of a play during a weekend retreat in the country (Kent, Connecticut, for this show). Tonight's performance is the end result.

---

**The 52nd Street Project Board of Directors**

Ben Barenholtz	Patricia M. Murphy, Esq.
Lisa Benavides	Carol Ochs
Rachel Chanoff	Willie Reale
Cathy Dantchik	Gus Rogerson
Noël Dawkins	Shirley Rumierk, <i>alumni member</i>
Wendy Ettinger, <i>chair emeritus</i>	José Soto, Jr., <i>alumni member</i>
Louis P. Friedman	Pamala Tyson
Stephen Graham, <i>chair</i>	Laura Valeroso
Larry Jones	Wendy vanden Heuvel
James McDaniel	John A. Vassilaros
Frances McDormand	Jenny Wiener

---

**Special Thanks**

We're grateful to Stephen and Cathy Graham for graciously allowing us to bring the chaos of a Playmaking weekend to their lovely home in Kent, Connecticut. Their staff, including Chef Eric and Jeannie, get a round of applause, too. Thanks also go to Sam and Lynn Waterston, and Liz and Paul Giamatti for providing overnight accommodations.

---

**In-Kind Contributions**

Ensemble Studio Theatre; Neil A. Mazzella and Hudson Scenic Studios; the Murphy Law Office; Iris A. Brown; Ron Kastner and Capital Printing; Big Apple Lights; Coleman; Noggin; The Printing Store; Scholastic, Inc.; Seagram's Chateau & Estate Wines; Shapiro & Lobel; Sesame Workshop; Watkins, Inc.; Mayor's Office of Film & Television; Boylan's Bottling Co.; David Sneddon & Fairway Market; Andy Millon; Steve Olsen & The Westbank Cafe; Lorraine Tobias & Imaginary Studios; Robert Goldberg and Yorke Construction; Jive Records, part of Zomba Music Group; Prime Films; and Cubic B's.

## HEART OF THE MATTER - ACT I

All original music composed by Rusty Magee

### Emotions

By Tiffany Paget, age 9. Dramaturg/Director: Megan Sandberg-Zakian  
Angel .....Angel Desai  
Jenny .....Rebecca White  
Other kids .....The Crew  
Bus Driver .....Osage Lewis-Ashley  
Miss Wonder .....Diana Rojas

*“Be Friends Forever”* lyrics by Tiffany Paget.

### Reddy’s Evil Plan

by Joshua Omana, age 10. Dramaturg/Director: Joe White

Reddy .....Dale Ho  
Jumpy .....Jonathan Goldblatt  
Bossy .....Kevin Geer

### On and Off

by Jazzlyn Hernandez, age 10. Dramaturg/Director: Peter Herdrich

Jessica Rodriguez .....Kaitlyn Kenney  
Julissa Cordero .....Karen Trott  
Partygoers .....The Crew

*“New Girl”* lyrics by Jazzlyn Hernandez

### A Football Player’s Dream

by John Cuevas, age 11. Dramaturg/Director: Marcella André

Tara Kwan .....Anna Li  
Jayson .....Jay Patterson  
Casper .....Joel Lind  
Bullies & Cheerleaders .....The Crew

*“A Song for an Angel”* lyrics by John Cuevas

### Cloudman and Sun vs. Meltman

by Chassity Damiani, age 10. Dramaturg/Director: Connie Grappo

Meltman .....Alex Draper  
Sun .....Femi Plimpton  
Cloudman .....John Sheehy  
Reporter/Dark Cat .....Catherine Glenn

*“Livin’ in Light”* lyrics by Chassity Damiani

👉 **Intermission!** 👈

## HEART OF THE MATTER - ACT II

### The Child Who Found His Mom

by Paul Dixon, age 11. Dramaturg/Director: Gus Rogerson

Tommy .....Kenajuan Bentley  
Carl .....Danyon Davis  
Tia .....Lenore Pemberton  
Security Guard .....Britta Jensen

### Chains of Love

By Megan Cruz, age 11. Dramaturg/Director: Liliana Amador

Dr. Pink .....Jennifer Ostrega  
Waitress .....Julia Walk Miller  
White Dove .....Stephanie Bast  
Robbers .....Joel Lind, Osage Lewis-Ashley, Steven Vasquez  
Love .....Catherine Glenn

*“Evil Pink”* and *“Girl Heroes”* lyrics by Megan Cruz

### The Fight Between Friends

by Caroline Rodriguez, age 11. Dramaturg/Director: Elizabeth Giamatti

Mac .....Kevin Geer  
Maranda .....Shirley Rumierk  
Team Captain .....Osage Lewis-Ashley

*“In My Tap Shoes”* lyrics by Caroline Rodriguez

### Let Me Stay

by Eddie Cuevas, age 12. Dramaturg/Director: Danny Goldstein

Greg .....David Grillo  
Barry .....Duane Boutté  
Claude .....Gus Rogerson  
Crowd .....The Crew  
Nurse .....Julie Gold

*“I Like Your House”* lyrics by Eddie Cuevas

### The Parrot and the Old House

by Christian Alvarez, age 11. Dramaturg/Director: Jace Alexander

Patty .....Maddie Corman  
Charles .....P.J. Brown  
T.V. Contest Announcer .....Gus Rogerson  
Danny Hamster .....John Sheehy  
Hollywood Man .....Michael Bernard

*“The Fat Cat”* and *“Charles and Me”* lyrics by Christian Alvarez

Corporate Hosts **Bear Stearns, Mosaic Entertainment, Tobak-Dantchik Events and Promotions** and the **Board of Directors of The 52nd Street Project** present



**BOARD CHAIR**

Stephen Graham

**ARTISTIC DIRECTOR EXECUTIVE DIRECTOR**

Gus Rogerson

Carol Ochs

## HONORARY CHAIR

Tom Cruise

## CO-CHAIRS

Lisa Benavides	Patrice Friedman
Becky Browder	Karin Schall
Cathy Dantchik	Laura Valeroso
Louis P. Friedman	Mary Pat Walsh
Jenny Wiener	

## THE BOARD OF DIRECTORS

Ben Barenholtz	Patricia M. Murphy, Esq.
Lisa Benavides	Carol Ochs
Rachel Chanoff	Willie Reale,
Cathy Dantchik	<i>founder</i>
Noël Dawkins	Gus Rogerson
Wendy Ettinger,	Shirley Rumierk
<i>chair emeritus</i>	José Soto, Jr.,
Louis P. Friedman	Pamala Tyson
Stephen Graham, <i>chair</i>	Laura Valeroso
Larry Jones	Wendy vanden Heuvel
James McDaniel	John Vassilaros
Frances McDormand	Jenny Wiener

### *The 52nd Street Project gratefully acknowledges...*

Giorgio Armani Parfums  
 Peter Contarino and Backstage Productions  
 Big Apple Lights  
 Iris A. Brown  
 Capital Printing/Ronald J. Kastner  
 Kenneth Cole Productions  
 Entertainment Weekly  
 Hudson Scenic Studios  
 Jive Records/A division of Zomba Music Group  
 Noggin  
 Kevin O'Shea and Jack Morton Williams, Inc.  
 The Post Factory  
 The Printing Store  
 Scholastic, Inc.  
 Diageo Chateau & Estate Wines Co.  
 Sesame Workshop  
 Wendy Stulberg  
 Ultimate Impressions  
 John A. Vassilaros & Sons  
 Watkins Incorporated  
*Healthier Living Since 1868*

## STILL STAYIN' ALIVE: THE SHOW THE ADULTS

Lewis Black, Kate Burton, Billy Crudup,  
 Peter Jay Fernandez, Peter Herdrich,  
 Michael Potts, Diana Rojas, Shirley Rumierk,  
 José Soto, Anne Torsiglieri and Karen Trott

### THE KIDS

Paul Dixon, Stephen Galimidi  
 and Suzette Santana

### LYRICS BY

Willie Reale

### MUSIC BY

Robert Reale

### DIRECTED BY

Jonathan Bernstein

### MUSIC DIRECTOR

Irwin Fisch

### WRITTEN BY

Willie Reale and John Sheehy

### DANCE CHOREOGRAPHER

Jeanne Simpson

### SET AND RIGGING CHOREOGRAPHER

Kevin Joseph Roach

### LIGHTING DESIGN

Greg MacPherson

### COSTUME DESIGN

Crystal Thompson

### SOUND DESIGN

Scott Lehrer

### STAGE MANAGER

Hank Meiman

### STILL STAYIN' ALIVE: THE FILM

Directed by Noël Dawkins and Wendy Ettinger

Edited by Tricia Cooke

Mixed by Dog Bark Sound

### FOAMCORE DESIGNS

George Babiak

### DISCO D.J.

Max Salpetrier



## THE HUSTLE TABLES

Bear Stearns  
 Arthur Dantchik  
 Cathy Dantchik  
 Patrice & Louis Friedman  
 Jenny Wiener & Jon Steingart,  
 Mosaic Entertainment  
 Jeffrey Yass

## THE ELECTRIC SLIDE TABLES

Wendy Ettinger & Derek McLane  
 Angelina Fiordellisi & Matt Williams  
 Cathy & Stephen Graham  
 Joanne Woodward & Paul Newman

## THE ROLLER BOOGIE TABLES

Vanessa Boeye & Ronald J. Kastner  
 Bob Boyett  
 Rachel Chanoff  
 Davis Polk & Wardwell  
 The Dawkins Family Foundation  
 Alexandra Gersten-Vassilaros &  
 Johnny Coffeeshopolis  
 Tricia & Mark Jacobs, Watkins Products  
 Fred Nelson, Entertainment Weekly  
 The New World Foundation  
 Ana Rosa & Peter Phillips  
 Jeremy M. Posner  
 Maury Schott  
 Laura Valeroso & David Seidman  
 Wendy vanden Heuvel  
 John & Ed Vassallo

## THE BUS STOP SEATS

Ben Barenholtz	Andrea L. Johnson
Tanya & Andrew Blackman, Shapiro & Lobel LLP	Traci Paige Johnson & Bob Mowen
Alfred C. Cerullo III Comedy Central	Elizabeth LeCompte & Willem Dafoe
Hyla & Rick Crane	John S. Lyons
Jennifer Crittendon & Bill Wrubel	Kay Matschullat & Allan Arffa
Rebecca & Richard Dresser	Fran McDormand & Pedro Coen
David Eigenberg Endeavor	Jane Musky & Tony Goldwyn
Nora Ephron	Sara & Don Nelson
Tom Feeney & Paul Parzuchowski	Jane Perlmutter & Greg MacPherson
Frank Frattaroli	Leslie & Dean Potashner
Janeane Garofalo	Linda & Hal Ritch
Jenny Gersten & Willie Reale	Anita A. & David S. Rogerson
Elizabeth & Paul Giamatti	Steve Sabba
Michael Greif & Jonathan Fried	Leslie Schine & Nils Nilsen
Lisa J. Gugenheim	Daniel Swee
Nyree Hartman & Mark Saad	Karen Trott & Peter Herdrich
Dana Ivey	Wendy Wasserstein
	Mary Lin & Jim Yoshimura



## THE BUMP SEATS

Joanne Akalaitis Alexis Alexanian Amazon Pixels Alice A. Arana	Judy Goldman & Michael Pillinger Robyn Goodman
Cecilia Arana-Grant & Kevin Grant Lucie Arnaz & Larry Luckinbill	Lizzie Gottlieb & Michael Young Flavia Grimm
June Ballinger & Michael Goldstein Talia Balsam & John Slattery	Jane & Jonathan Heine Kathy Hiler & Daniel Jenkins
Arija Bareikis Benny Bartley Terry Belanger Stephen Bernstein	Katheryn Holt & Kirk Citron Katy Homans & Patterson Sims
Vicky Bijur & Ed Levine Jane Bolster & Steve Wertimer	Matt Houston Amanda Johns Marcy & Max Kahn
Kathy Borowitz & John Turturro Buzz Bovshow Julie Boyd	Eric Karpeles & Mike Sell Evelyn Kenvin & Arthur Rosenbloom
Becky Browder & Ted Neustadt Susan Bruce & Peter Hedges	Woodie King, Jr. Judy Kuhn & David Schwab
Denise Burse & Peter Jay Fernandez	Jill Larson Nanette & Allan Larson
Alison Fraser & Rusty Magee & Nat Magee	Kate Lear & Jonathan LaPook Warren Leight Mickey Lemle Liza Lerner
Cora Cahan & Bernard Gersten Camilla Campbell & Oliver Platt	Aimee Levine Josh Lewis Anna Antonia Li Linda Li
Colleen Carroll & Mitchell Semel Phoebe Cates & Kevin Kline	Vince Liebhart Jessica Lissy Adrienne Lobel & Mark Linn-Baker
Sharon Chantiles Glenda Chesshir Darrah Cloud & Dave Owens	Barry Lee Mackall Wendy Makkena & Bob Krakower
Ruth Cohen David Copeland Maddie Corman & Jace Alexander	Sonya Martin John Matoian George Mayer Brigid McCarthy
Catherine Corpeny & Max D. Mayer Margaret Crimmins Peter Cross	Sandra McClain Barbara McCrane & Paul Reale
Anna E. Crouse Emily Crow	Jerry McGill Rick Meese Danny Meisner
Catherine Curtin & Randy Myler Georgia & Billy Delano	Josie Merck & James Stevenson Bob Morris Meg Mortimer
Stephen V. DeRosa Dramatists Play Service	Suzen Murakoshi & Mark Temme
Moira Driscoll & David Pence Christine Dunn & Steve Callahan	Patricia Murphy & Adam Spilka Dr. Mark Nesselson & Elliot Rosenblum
Patricia Dunnock & Ned Eisenberg	Ricarda O'Connor Lori O'Connor
Karen & Christopher Eddowes Mario Egozi	Carol Ochs & Bruce MacVittie Jacki Ochs & Jan Kroeze
Josephine Eke & Jason Valk Beth Emelson Martin Ross Fetner	Susan Ochs Phillips Lu Ann S. & William M. Polk
Anita Flanagan Alexa L. Fogel	Christopher Randolph Theresa Rebeck & Jess Lynn
Deborah Freedman & Bill Woods Katherine Freedman & Brian Beirne	Alysia Reiner & David Alan Basche
Rose Gasner & Larry Chertoff Jilian Cahan Gersten	LaTanya R. Richardson & Samuel L. Jackson
Ileen Getz & Mark Grinnell Toni Giamatti	Daryl Roth Martha Roth & Bill Irwin
Nancy Giles Kilty & Lloyd Gilmour	Esther & Stan Royce



PHOTOS BY WENDY STULBERG

Caroline Ryan Laura Sametz Zeborah Schachtel Karin & Thomas Schall Mary Anne & Ken Schuster Richard Schwartz	Paola Styron Susanna Styron & Darrell Larson Mariko Tada Crystal Thompson & Chris Ryan Edith Thurber & Kevin O'Rourke Suzanne Tobak
Whitney Scott & Peter Jacobson Dana Segal & Andrew Hurwitz Stefan M. Selig Sylvia Shepard & Willy Holtzman	Lorraine Tobias & Alex Draper Liz Tuccillo Susan J. Vitucci Mary Pat Walsh Mildred & Borah Walton
Kim D. Sherman Abby Sigal Meg Simon Landon Slane Lois Smith	Maja Wampuszyc Anita Waxman Anne Weiss Carol Whitesides Elizabeth Williams & Joseph Forte
Abigail Rose Solomon Frank Sposato Erena Stennett Sara & David Stone	Ellis Williams Hannah & Andy Wolk Yildiz Yuksek & Richard Blackstone
Abbott Stranahan & David Ward Lynn Street & Donald Margulies	Ginger Zakian & Bob Sandberg

List current as of 5/8/02

## THE 52ND STREET PROJECT STAFF

Gus Rogerson, Artistic Director  
 Carol Ochs, Executive Director  
 Michael Bernard, Associate Artistic Director  
 John Sheehy, Director of Development and Marketing  
 George Babiak, Production Manager  
 Julie Feldman-Abe, Director of Education  
 Megan Sandberg-Zakian, Volunteer Coordinator  
 Chris Ceraso, Teen Dean  
 Liz Bell, Education Assistant  
 Diana Rojas, Executive Assistant  
 Iris A. Brown, Graphic Designer  
 Catherine Glenn, Britta Jensen,  
 Julia Walk Miller; Interns

## BENEFIT VOLUNTEERS

Heather Carnduff-Gobbée, Tim Gallagher,  
 Martin Gobbée, Dale Ho,  
 Doug Lockwood, Perry McBain Daniel,  
 Susan McGinnis, Chris Ryan,  
 Vanessa Valdes

## SPECIAL THANKS

Willem Dafoe, Beth Emelson,  
 Jenny Gersten, Joe Mihalow,  
 Hank Rogerson, Karin Schall,  
 Jilann Spitzmiller, Mary Pat Walsh

LAYOUT BY GEORGE BABIAK

The 52nd Street Project gratefully acknowledges the support of the following foundations and corporations: Barker Welfare Foundation, The Barnsley Foundation, Capital Research Company, Carnegie Corporation of New York, Comedy Central, Consolidated Edison, The Dammann Fund, Davis Polk & Wardwell, The Dramatists Guild Fund, Dramatists Play Service, Eleanor, Adam & Mel Dubin Foundation, The Educational Foundation Of America, Entertainment Weekly, Ford Foundation, The J. Paul Getty Trust, The Horace W. Goldsmith Foundation, The Hennessy Foundation, Holland Lodge Foundation, Hudson Scenic Studio, Betty E. & George B. Kaiser Foundation, Rita J. and Stanley H. Kaplan Foundation, Lloyds TSB Bank, Lucille Lortel Foundation, Lucent Technologies, Mellon Bank, Helen Merrill, The Cynthia & George Mitchell Foundation, J.P. Morgan Charitable Trust, The National Board of Review, Newman's Own, The New World Foundation, The New York Times, Paramount Pictures, Laura Pels Foundation, Roulette Entertainment, The Fan Fox & Leslie R. Samuels Foundation, Staging and Design, The Surdna Foundation, Susquehanna Partners, Theatre Communications Group, The Vervane Foundation, West Bank Cafe, Yorke Construction Corp., Felix Zaremba & Co. Inc. (List current as of 7/24/02)

Robert Abrams & Cynthia Vance  
 Jace Alexander & Maddie Corman  
 Cecilia Arana-Grant & Kevin Grant  
 Lucie Amaz & Laurence Luckinbill  
 Debbon Ayer  
 Mary Bacon & Andrew Leynse  
 June Ballinger & Michael Goldstein  
 Ben Barenholtz  
 Benny Bartley  
 Jessica Bauman  
 Laurie Becker & Rick Sweren  
 Meredith Beeuwkes  
 Gregory Bello  
 Lisa Benavides & Tim Nelson  
 Barry & Myrna Bernard  
 Alexander & Elizabeth Bernstein  
 Stephen Bernstein  
 Vicky Bijur & Ed Levine  
 Reed Birney & Connie Shulman  
 Lewis Black  
 Jeanette & Samuel Black  
 Richard Blackstone & Yldeez Yuksek  
 Tessa Blake  
 Buzz Boyshov  
 Bob Boyett  
 Alan Braverman  
 Kathy Briggs  
 Becky Browder & Ted Neustadt  
 Susan Bruce & Peter Hedges  
 Kate Burton & Michael Ritchie  
 Linda & Arthur Carter  
 Alfred C. Cerullo III  
 Rachel Chanoff  
 Sharon Chantile  
 Ellen Chenoweth  
 Glenda Chesshir  
 Marissa & Travis Chibas  
 Kirk & Katherine Holt Citron  
 Darah Cloud & Dave Owens  
 Ethan Coen & Trish Cooke  
 Ruth Cohen  
 Jerome Cohen Congress  
 Lieta Hesen-Cohen & Richard Cohn  
 David Copeland  
 Hyla & Richard Crane  
 Margaret Cimmins  
 George & Cathy Crow  
 Cameron Crowe  
 Stephen & Sandra Crudgington  
 Tom Cruise  
 Catherine Curtin  
 Willem Dafoe & Liz Lecompte  
 Arthur Dantchik  
 Cathy Dantchik  
 Peter & Judith Dawkins  
 Georgia & William Delano  
 Jonathan Demme  
 Buddy Dikman & Chuck Davis  
 Edward & Joanne DiRugieris  
 Jon Divis & Gene Reilly  
 Richard & Rebecca Dresser  
 Moira & David Driscoll  
 Christopher & Karen Eddowes  
 Mario Egozi  
 David Eigenberg  
 Ned Eisenberg & Patricia Dunnock  
 Nora Ephron  
 Barbara Ettinger & Sven Huseby  
 Barbara Ettinger  
 Heidi Ettinger  
 Wendy Ettinger & Derek McLane  
 Tom Feeney & Paul Parzuchowski  
 Adam Felber & Jeanne Simpson  
 Peter Jay Fernandez & Denise Burse  
 Martin Ross Fetner  
 Hannah Finn & John Wiltshire  
 Billy Finnegan  
 Angelina Fiordellisi  
 Terry Fitzpatrick & Stephen Perpeluk  
 Anita Flanagan & Jeff Potter

Alexa Fogel  
 David Frankel  
 Eric & Juli Frankel  
 Richard Frankel & Kathleen Clark  
 Frank Frattaroli  
 Katherine Freedman  
 Naomi Freundlich & Charles Miles  
 Louis & Patrice Friedman  
 Victor Garber  
 Janeane Garofalo  
 Rose Gasner & Larry Chertoff  
 Joseph & Margaret Gazdak  
 Cora Cahlan & Bernard Gersten  
 Jillian Cahlan Gersten  
 Ileen Getz & Mark Grinnell  
 Paul & Elizabeth Giamatti  
 Nancy Giles  
 Lloyd & Kilty Gilmour  
 Bob Glennon  
 Bryan Gmitter  
 Judy Goldman & Michael Pillingner  
 Wendy Goldman  
 Tony Goldwyn & Jane Musky  
 Fred & Nancy Goodman  
 Stephen & Cathy Graham  
 Connie Grappo & Lee Wilkof  
 Michael Greif & Jonathan Fried  
 Mary Grieco  
 Emily Grishman & Susan Sampliner  
 Lisa Lugenheim  
 Mark & Valerie Hadjipateras  
 James A. Macdonald Foundation  
 Evan Handler  
 Lynn E. Harris  
 Jane & Jonathan Heine  
 Amy Henkels  
 David Herdrich & Elizabeth Palmer  
 Herdrich  
 Peter Herdrich & Karen Trott  
 William Holtzman & S. Sylvia Shepard  
 Katy Homans & Patterson Sims  
 Barbara Howard  
 Kate Hudson & Chris Robinson  
 Michelle Hurst  
 Dana Ivey  
 Mark Evan Jacobs  
 Sy Jacobs  
 Whitney Scott & Peter Jacobson  
 Linda LeRoy Janklow  
 Macon R. & Michael B. Jessop  
 Amanda Johns  
 Julia A. Johns  
 Andrea Johnson  
 Traci Paige Johnson & Robert Mowen  
 Cherry Jones & Mary O'Connor  
 Larry & Mary Jones  
 Marcy & Max Kahn  
 Maurice Kanbar  
 Eric Karpeles & Mike Sell  
 Ronald Kastner & Vanessa Boeys  
 Lisa A. Kauffman  
 Stephen & Sharon Kepniss  
 Seth & Beth Klarman  
 Alan & Kathryn Klingenstein  
 Joana & Jason Klot  
 Mary Kong  
 Judy Kuhn & David Schwab  
 Roger & Belle Kuhn  
 Lynn Landis  
 Mark Lanow & Joanne Astrow  
 Allan & Nanette Larson  
 Jill Larson  
 Michael P. Lawrence  
 Kate Lear & Jonathan LaPook  
 Mary Ann Lefort  
 Howard Leifman  
 Warren Leight  
 Mitchell Lemsky & Jane Bodle  
 Liza Lerner  
 Becky & Steven Lewis

Joshua Lewis  
 Anna Li  
 Linda Li  
 Mark Linn-Baker & Adrienne Lobel  
 Margo Lion  
 Jessica Lissy  
 Adrienne Lobel & Mark Linn Baker  
 Richard & Susan Lobel  
 John Lyons  
 Grace Lyu-Volkhausen  
 Barry Mackall & Bill Schwinghammer  
 Marsue & Peter MacNicol  
 Greg MacPherson & Jane Perlmutter  
 Rusty Magee & Alison Fraser  
 Wendy Makkena & Bob Krakower  
 Paul & Lauren Mandell  
 Elizabeth Manne  
 Peter Manning & André Bishop  
 Donald Margulies & Lynn Street  
 Richard Marin  
 Ali Marsh  
 Jesse L. Martin  
 Kay Matschullat & Allan Arfa  
 Dave & Alicia Matthews  
 Stephen & Cathy Graham  
 Brigid McCarthy  
 Michael Greif & Jonathan Fried  
 Paul McCrane & Dana Kellin  
 Fran McDormand & Joel Coen  
 William Michael McMahon & Meg  
 McMahon  
 Rick Meese & Dan Lori  
 Richard & Denise Menelly  
 Lynn E. Harris  
 Jane & Jonathan Heine  
 Amy Henkels  
 David Herdrich & Elizabeth Palmer  
 Herdrich  
 Peter Herdrich & Karen Trott  
 William Holtzman & S. Sylvia Shepard  
 Katy Homans & Patterson Sims  
 Barbara Howard  
 Kate Hudson & Chris Robinson  
 Michelle Hurst  
 Dana Ivey  
 Mark Evan Jacobs  
 Sy Jacobs  
 Whitney Scott & Peter Jacobson  
 Linda LeRoy Janklow  
 Macon R. & Michael B. Jessop  
 Amanda Johns  
 Julia A. Johns  
 Andrea Johnson  
 Traci Paige Johnson & Robert Mowen  
 Cherry Jones & Mary O'Connor  
 Larry & Mary Jones  
 Marcy & Max Kahn  
 Maurice Kanbar  
 Eric Karpeles & Mike Sell  
 Ronald Kastner & Vanessa Boeys  
 Lisa A. Kauffman  
 Stephen & Sharon Kepniss  
 Seth & Beth Klarman  
 Alan & Kathryn Klingenstein  
 Joana & Jason Klot  
 Mary Kong  
 Judy Kuhn & David Schwab  
 Roger & Belle Kuhn  
 Lynn Landis  
 Mark Lanow & Joanne Astrow  
 Allan & Nanette Larson  
 Jill Larson  
 Michael P. Lawrence  
 Kate Lear & Jonathan LaPook  
 Mary Ann Lefort  
 Howard Leifman  
 Warren Leight  
 Mitchell Lemsky & Jane Bodle  
 Liza Lerner  
 Becky & Steven Lewis

Herald & Linda Ritch  
 Loree Rodkin  
 David & Anita Rogerson  
 Robin Morse & Gus Rogerson  
 Clifford & Betsy Ross  
 Gaylen Ross  
 Daryl Roth  
 Alexander Roy  
 Mark Saad  
 Steve Sabba  
 Laura Sametz  
 Tim & Lisa Sanford  
 Zeborah Schachtel  
 Stacey Schaffer & Eric Schwartz  
 Karin & Tom Schall  
 Leslie Schine & Nils Nilsen  
 Beth Schneider  
 Maury Schott  
 Ken & Mary Ann Schuster  
 Stefan Selig  
 Jeffrey Seller & Joshua Lehrer  
 Mitchell Semel & Colleen Carroll  
 Alyson Shapero  
 Aaron & Elaine Shapiro  
 Jonathan Sheffer  
 Abby Jo Sigal & Matt Turner  
 Meg Simon  
 Landon Slane  
 Talia Balsam & John Slattery  
 Lois Smith  
 Phillip K. & Gloria W. Smith  
 Abigail Rose Solomon  
 Dr. David Solowiejczyk  
 John Steber & Robert Shaffron  
 Jean Stein  
 Ben & Christine Stiller  
 David & Sara Stone  
 Abby Stranahan & Dave Ward  
 Susanna Styron & Darrell Larson  
 Brian Swardstrom  
 & Bonnie Bernstein  
 John Morning  
 Bob Morris  
 Meg Mortimer  
 Suzen Murakoshi  
 Patricia M. Murphy, Esq. & Adam Spilka  
 Timothy Murtha & Elizabeth McDermott  
 Heather & Eileen Nash  
 Don & Sara Nelson  
 Pamela & Peter Nelson  
 Randy & Rona Nelson  
 Ruth Nelson  
 Mark Nesselson, M.D. & Elliott  
 Rosenblum  
 James Neuberger & Helen Stambler  
 Ricarda O'Connor & Michael Ottavi  
 Lori O'Connor  
 Steven O'Neill  
 Kevin O'Rourke & Edith Thurber  
 Carol Ochs & Bruce MacVittie  
 Jacki Ochs & Jan Kroeze  
 Paul & Maria Onderdonk  
 Steven & Margot Peter  
 Elizabeth Peters  
 Bat-Sheva & Thomas Peters  
 Peter & Ana Rosa Phillips  
 Susan Ochs Phillips  
 Oliver Platt & Camilla Campbell Platt  
 Richard Potatchek  
 Jeremy Posner  
 Dean & Leslie Potashner  
 Michael Potts  
 Gigi Pritzker Pucker & Michael Pucker  
 Christopher Randolph  
 Peter & Helen Randolph  
 Paul Reale & Barbara McCrane  
 Willie Reale & Jenny Gersten  
 Theresa Rebeck & Jess Lynn  
 Alysia Reiner & David Basche  
 Lucy E. Retan

The 52nd Street Project presents  
 The 2002 Harold and Mimi Steinberg Charitable Trust One-on-Ones

# TEN FOR THE ROAD: THE TRAVELING PLAYS

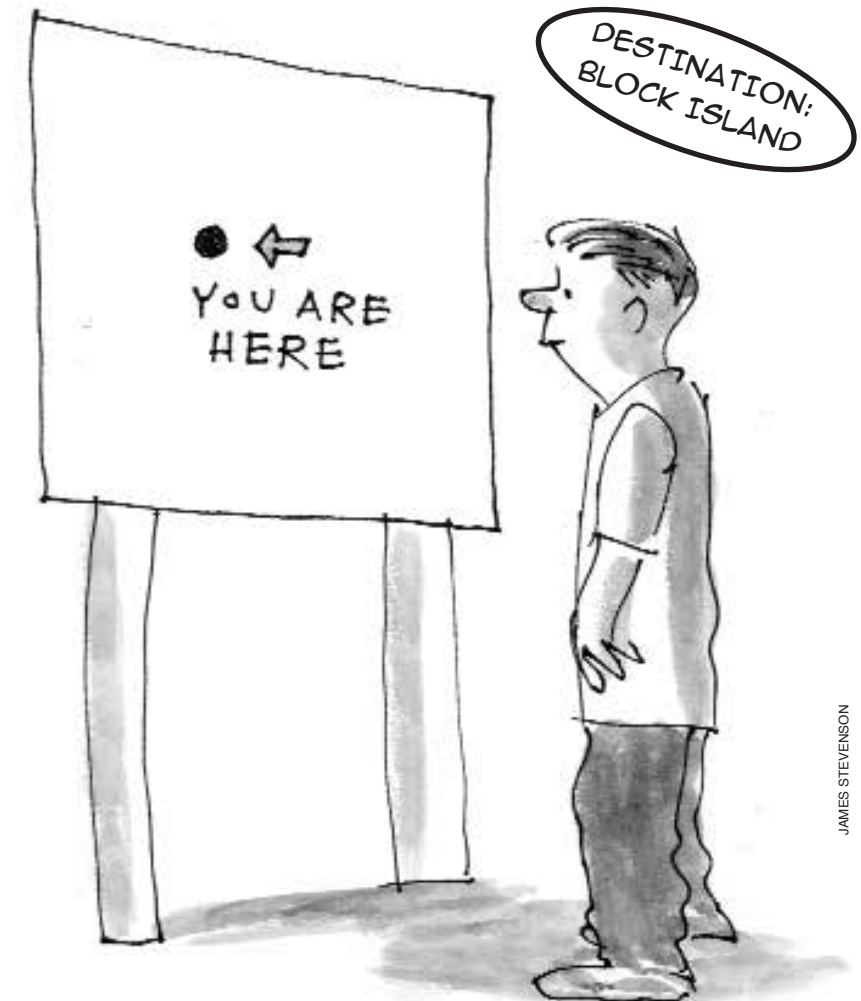

JAMES STEVENSON

JULY 25-28, 2002  
 THE ENSEMBLE STUDIO THEATRE  
 549 WEST 52ND ST., NEW YORK CITY

# TEN FOR THE ROAD: THE TRAVELING PLAYS

The 2002 Block Island  
One-on-Ones  
July 25-28  
The Ensemble Studio Theatre

## The 52nd Street Project Staff:

Gus Rogerson, Artistic Director  
Carol Ochs, Executive Director  
John Sheehy, Director of Development and Marketing  
Megan Sandberg-Zakian, Associate Artistic Director  
George "X-Acto" Babiak, Production Manager  
Liz Bell, Director of Education  
Diana Rojas, Executive Assistant  
Chris Ceraso, Teen Dean  
Iris A. Brown, Graphic Designer  
Mayleen Cancel and Zsuzsa Mysak, Receptionists  
Interns: Conor Fetting-Smith, Charlotte Howard, Beth McMahon

## Production Staff

**Composer:** Kim D. Sherman  
**Set Designer:** Kevin Joseph Roach  
**Lighting Designer:** Abigail Felder  
**Asst. Lighting Designer:**  
Kelly Blackwell  
**Costume Designer:** Janet Edwards  
**Costume Assistant:** Lee Harper  
**Sound Designer:** Vanessa Valdes  
**Stage Manager:** Perry McBain-Daniel  
**Slide Design Team:**  
Katherine Lumb, Monty Nicol, Kim  
Snow, John Steward, Iwona Waluk  
**Prop Design Team:**  
George Babiak, Stephanie Bast,  
Heather Carnduff, Monique Curnen,  
Conor Fetting-Smith, Charlotte  
Howard, Beth McMahon, Rick  
Meese, Niambi Nataki, Rachel  
Schroeder, John Sheehy

## Flyer/Program Illustrations:

James Stevenson

## Furniture Crew:

Conor Fetting-Smith, Adalberto  
Rodriguez, Johnathan "Big J" Roldan

## Prop Crew:

Charlotte Howard, Jennifer Jimenez,  
Beth McMahon

## Load-in and Light-hang Crew:

Conor Fetting-Smith, Charlotte  
Howard, Beth McMahon, Tim  
Gallagher, Noel Polanco, Tom Schall

## House Managers:

Liz Bell, Karin Schall, Mary Pat Walsh

## Chefs:

Pat McQuade and Martha Velie-Gass

## Teen Counselor:

Jennifer Jimenez



NATIONAL  
ENDOWMENT  
FOR THE ARTS

The One-on-Ones Program is made possible with public funds from the National Endowment for the Arts; The New York State Council on the Arts, a state agency; the Department of Youth and Community Development; and the New York City Department of Cultural Affairs. The 52nd Street Project is a member of Art/NY and a participant in the New Generations Program, funded by Doris Duke Charitable Foundation/The Andrew W. Mellon Foundation and administered by Theatre Communications Group, the national organization for the American Theater.

State of the Arts



NYSCA

# COOL STUFF ON SALE IN THE LOBBY!

The Fabulous Flyer Bar . . . . . \$2.00 & \$1.50  
and featuring Shel Silverstein's "Fivey and Twoey" logo:  
Project T-shirts . . . . . \$12.00  
Project Tank Tops . . . . . \$12.00  
Project Caps (NEW design) . . . . . \$15.00  
Project Mugs (now in BLUE!) . . . . . \$5.00  
Project Pencil 3-pack (now in RED!) . . . . . \$1.00

Thank you for coming to **TEN FOR THE ROAD!** If you are not on our mailing list (or if your address has changed), please fill out this form and give it to us on your way out or mail it to the address below. We would also like to know if you are interested in becoming a volunteer. We need help in **all areas**, so be sure to fill out the entire form.

## PLEASE ADD ME TO YOUR MAILING LIST:

7/02

NAME: \_\_\_\_\_

ADDRESS: \_\_\_\_\_

ZIP \_\_\_\_\_

HOME PHONE: \_\_\_\_\_

DAYTIME PHONE: \_\_\_\_\_

E-MAIL ADDRESS: \_\_\_\_\_

MY OCCUPATION: \_\_\_\_\_

MY HOBBIES: \_\_\_\_\_

## YES, I WOULD LIKE TO BE OF HELP. I CAN:

- |   |   |  |
|---|---|--|
| <input type="checkbox"/> Help load in and out for shows | <input type="checkbox"/> Draw and/or paint  | <input type="checkbox"/> Help kids with homework |
| <input type="checkbox"/> Hang lights                    | <input type="checkbox"/> Help with mailings | <input type="checkbox"/> Teach kids a skill      |
| <input type="checkbox"/> Work on a backstage crew       | <input type="checkbox"/> Do office work     | <input type="checkbox"/> Be a chef at an event   |
| <input type="checkbox"/> Do graphic design              | <input type="checkbox"/> Design sound       | <input type="checkbox"/> Design and sew costumes |
| <input type="checkbox"/> Other (please specify) _____   |   |  |

## MY SCHEDULE IS:

- Very flexible. I'm often available during weekdays.  
 Somewhat flexible. I can help on the occasional morning or afternoon during the week.  
 Not very flexible at all, but I've got some free time on evenings and weekends.

If you would like to mail this (and you're always welcome to enclose a tax-deductible contribution), you can send it to: **The 52nd Street Project**, 500 West 52nd St., New York, NY 10019. Or fax it to (212) 333-5598.

## Don't Miss Our Upcoming Shows!

### TEN MORE FOR THE ROAD



THE SECOND OUTING OF THE 2002 ONE-ON-ONES  
AUGUST 22-25 RIGHT HERE AT E.S.T.  
SAME GREAT THEME, BUT WITH NEW KIDS,  
NEW ADULTS, AND ALL-NEW PLAYS.

## **PLAYBACK**

November, 2002

First a kid writes a short play. Then, an adult writes an "answer" play. Then, the two of them perform both plays. Multiply this equation by seven and you've got an entire show.



December, 2002

In September, 10 kids brand-new to the Project will begin a Playmaking class taught by Project Playmaking Director Megan Sandberg-Zakian. Come and see their final plays performed by adult professional actors.

The 52nd Street Project is a non-profit organization that brings children from the Hell's Kitchen neighborhood together with professional theater artists to create original theater. **TEN FOR THE ROAD** is a production of our One-on-One program, which is designed to give children the opportunity to go away for one-week stays in the country and enjoy the undivided attention of a professional theater artist who serves as friend, mentor, and collaborator. The Project is delighted to return to the Ensemble Studio Theatre, where we have been performing since our inception in 1981. We gratefully acknowledge the fact that if E.S.T. wasn't here, we'd be nowhere.

### The 52nd Street Project Board of Directors

Ben Barenholtz  
Lisa Benavides  
Rachel Chanoff  
Cathy Dantchik  
Noël Dawkins

Wendy Ettinger, *chair emeritus*  
Louis P. Friedman  
Stephen Graham, *chair*  
Larry Jones  
James McDaniel  
Frances McDormand

Patricia M. Murphy, Esq.  
Carol Ochs  
Willie Reale, *founder*  
Gus Rogerson  
Shirley Rumierk, *alumni member*  
José Soto, Jr., *alumni member*  
Pamala Tyson  
Laura Valeroso  
Wendy vanden Heuvel  
John A. Vassilaros  
Jenny Wiener

### Special Thanks

Our Host Families – Pat McQuade & Martha Velie-Gass; Josie Merck & Jim Stevenson; Eliot & Amy Nerenberg; Jennifer & Elliot Taubman; Diane Trippler & Don Frageau; Ron, Judy & Kevin Tierney; Joya Verde & Anthony & Nicole Frye & Virginia Dare; Thomas Frye and our headquarters host Dr. Christina Biaggi. Sincere thanks also go to Lynn Reale, Kate & Harold at Block Island Realty; Prudy & The Ice Cream Place; Rita & Steve Draper; Jane Muskey & Tony Goldwyn ; Glenn & Annie Hall; McQuade's Market; Interstate Navigation; Sophia Ochs MacVittie; Jenny Ritter; Amanda Gass; Kirk Littlefield; Joe and Pat at Smuggler's Cove Sailing School; Finns, Block Island Grocery.

### In-Kind Contributions

Curt, Jamie, Suzanne, Carl, Tim, and everyone at the Ensemble Studio Theatre; Neil A. Mazzella and Hudson Scenic Studios; the Murphy Law Office; Iris A. Brown; Ron Kastner and Capital Printing; Big Apple Lights; Coleman; Noggin; The Printing Store; Scholastic, Inc.; Diageo Chateau & Estate Wines; Sesame Workshop; Watkins, Inc.; Mayor's Office of Film & Television; Boylan's Bottling Co.; David Sneddon & Fairway Market; Andy Millon; Steve Olsen & The Westbank Cafe; Lorraine Tobias & Imaginary Studios; Robert Goldberg and Yorke Construction; Jive Records, part of Zomba Music Group; and Prime Films.

## TEN FOR THE ROAD – ACT I

All original music composed by Kim D. Sherman  
“Ten for the Road Theme Song” lyrics by John Sheehy

### SHERMIE THE WORMIE

Written by Michael Bernard & Directed by Jessalyn Gilsig  
for Jazzy Hernandez, age 11

Shermie .....Jazzy Hernandez  
Purdy .....Jessalyn Gilsig

*“The Song of Shermie” & “Birds & Worms”* by Michael Bernard

### A THING FOR ISLANDS

Written by Julie McKee & Directed by Susan McGinnis  
for Leah Galimidi, age 14

Sharon .....Susan McGinnis  
Leilani .....Leah Galimidi  
Pilot’s Voice .....Jennifer Jimenez  
Radio Announcer .....John Sheehy

*“State Song”* by Julie McKee & Susan Vitucci; *“Real Hawaii”* by Julie McKee

### J’AI PEUR ... MOI AUSSI

Written by David Schwab & Directed by Carlo Alban  
for Anthony Mejia, age 12

Bellhop .....Anthony Mejia  
George .....Carlo Alban  
Iguana .....Beth McMahon

*“I’m Afraid So” & “Feel Your Fear”* by John Sheehy

### HAPPY TRAILS

Written by Jim Stevenson & Directed by Niambi Nataki  
for Suzette Santana, age 11

Marilyn .....Suzette Santana  
Angelica’s Mom .....Diana Rojas  
Angelica .....Jennifer Jimenez  
Sundown .....Niambi Nataki

*“Teddy Bear Blues” & “Friend Around the Bend”* by Jim Stevenson

### HAVING SEEN THE LIGHT

Written by Willie Reale & Directed by Kenajuan Bentley  
for Kimani Lewis-Ashley, age 12

Heathcliff .....Kimani Lewis-Ashley  
Norbert .....Kenajuan Bentley

*“Shooting the Breeze in Limbo”* by Willie Reale

 **Intermission!** 

## TEN FOR THE ROAD – ACT II

### BIRTH OF A SALESMAN

Written By Susan Kim & Directed by Stephanie Bast  
for Solangee Acosta, age 13

Jessica .....Solangee Acosta  
Apartment voices .....Crew  
Rozonda .....Stephanie Bast  
Betty Faye .....Diana Rojas

*“The Sell Spiel”* by John Sheehy

### DEEP TROUBLE

Written & Directed by George Babiak  
for Alex Tomas, age 11

Sandy Shortz .....Beth McMahon  
Fin Harper .....George Babiak  
Johnny Ramos .....Alex Tomas  
The Visitor .....Charlotte Howard

*“The Deep, Deep Blues”* by George Babiak

### BAGGAGE

Written & Directed by Doug Lockwood  
for Megan Cruz, age 11

Jana, Rocket LaVoom,  
Toots McKenzie, and Connie Caboose .....Megan Cruz  
Swiftly LaVoom .....Doug Lockwood  
Announcer .....John Sheehy  
Two Bad Kids .....Jennifer Jimenez, Diana Rojas  
Lita .....Jennifer Jimenez

*“Unpack”* by Doug Lockwood & John Sheehy

### COFFEE, TEA OR MY LEFT FOOT

Written by John Sheehy & Directed by Monique Curnen  
for Tiffany Paget, age 10

Krissy .....Tiffany Paget  
Helga .....Monique Curnen

*“Having a Friend”* by John Sheehy

### STILL WAITING FOR ...

Written by Bruce MacVittie & Directed by David Costabile  
for Stephen Galimidi, age 12

Didi .....Stephen Galimidi  
Gogo .....David Costabile

*“Next to You”* by Bruce MacVittie

These shows are performed in celebration of the lives of our dear friends  
Pat Walsh and Bob Reale.

The 52nd Street Project gratefully acknowledges the support of the following foundations and corporations: Barker Welfare Foundation, The Barnsley Foundation, Capital Research Company, Carnegie Corporation of New York, Comedy Central, Consolidated Edison, The Dammann Fund, Davis Polk & Wardwell, The Dramatists Guild Fund, Dramatists Play Service, Eleanor, Adam & Mel Dubin Foundation, The Educational Foundation Of America, Entertainment Weekly, Ford Foundation, The J. Paul Getty Trust, The Horace W. Goldsmith Foundation, The Hennessy Foundation, Holland Lodge Foundation, Hudson Scenic Studio, Betty E. & George B. Kaiser Foundation, Rita J. and Stanley H. Kaplan Foundation, Lloyds TSB Bank, Lucille Lortel Foundation, Lucent Technologies, Mellon Bank, Helen Merrill Ltd., The Cynthia & George Mitchell Foundation, J.P. Morgan Charitable Trust, The National Board of Review, Newman's Own, The New World Foundation, The New York Times, Paramount Pictures, Laura Pels Foundation, Roulette Entertainment, The Fan Fox & Leslie R. Samuels Entertainment, Staging and Design, The Surdna Foundation, Susquehanna Partners, Theatre Communications Group, The Vervane Foundation, West Bank Cafe, Yorke Construction Corp., Felix Zaremba & Co. Inc. (List current as of 7/24/02)

Robert Abrams & Cynthia Vance  
 Jace Alexander & Maddie Corman  
 Cecilia Arana-Grant & Kevin Grant  
 Lucie Amaz & Laurence Luckinbill  
 Debbon Ayer  
 Mary Bacon & Andrew Leynse  
 June Ballinger & Michael Goldstein  
 Ben Barenholtz  
 Benny Bartley  
 Jessica Bauman  
 Laurie Becker & Rick Sweren  
 Meredith Beeuwkes  
 Gregory Bello  
 Lisa Benavides & Tim Nelson  
 Barry & Myrna Bernard  
 Alexander & Elizabeth Bernstein  
 Stephen Bernstein  
 Vicky Bijur & Ed Levine  
 Reed Birney & Connie Shulman  
 Lewis Black  
 Jeanette & Samuel Black  
 Richard Blackstone & Yldeez Yuksek  
 Tessa Blake  
 Buzz Boyshov  
 Bob Boyett  
 Alan Braverman  
 Kathy Briggs  
 Becky Browder & Ted Neustadt  
 Susan Bruce & Peter Hedges  
 Kate Burton & Michael Ritchie  
 Linda & Arthur Carter  
 Alfred C. Cerullo III  
 Rachel Chanoff  
 Sharon Chantile  
 Ellen Chenoweth  
 Glenda Chesshir  
 Marissa & Travis Chibas  
 Kirk & Katherine Holt Citron  
 Darah Cloud & Dave Owens  
 Ethan Coen & Trish Cooke  
 Ruth Cohen  
 Jerome Cohen Congress  
 Lieta Hesen-Cohen & Richard Cohn  
 David Copeland  
 Hyla & Richard Crane  
 Margaret Cimmins  
 George & Cathy Crow  
 Cameron Crowe  
 Stephen & Sandra Crudgington  
 Tom Cruise  
 Catherine Curtin  
 Willem Dafoe & Liz Lecompte  
 Arthur Dantchik  
 Cathy Dantchik  
 Peter & Judith Dawkins  
 Georgia & William Delano  
 Jonathan Demme  
 Buddy Dikman & Chuck Davis  
 Edward & Joanne DiRugieris  
 Jon Davis & Gene Reilly  
 Richard & Rebecca Dresser  
 Moira Driscoll & David Pence  
 Christopher & Karen Eddowes  
 Mario Egozi  
 David Eigenberg  
 Ned Eisenberg & Patricia Dunnock  
 Nora Ephron  
 Barbara Ettinger & Sven Huseby  
 Barbara Ettinger  
 Heidi Ettinger  
 Wendy Ettinger & Derek McLane  
 Tom Feeney & Paul Parzuchowski  
 Adam Felber & Jeanne Simpson  
 Peter Jay Fernandez & Denise Burse  
 Martin Ross Fetner  
 Hannah Finn & John Wiltshire  
 Billy Finnegan  
 Angelina Fiordellisi & Matt Williams  
 Terry Fitzpatrick & Stephen Persepeluk  
 Anita Flanagan & Jeff Potter

Alexa Fogel  
 David Frankel  
 Eric & Juli Frankel  
 Richard Frankel & Kathleen Clark  
 Frank Frattaroli  
 Katherine Freedman  
 Naomi Freundlich & Charles Miles  
 Louis & Patrice Friedman  
 Victor Garber  
 Janeane Garofalo  
 Rose Gasner & Larry Chertoff  
 Joseph & Margaret Gazdak  
 Cora Cahlan & Bernard Gersten  
 Jillian Cahlan Gersten  
 Ileen Getz & Mark Grinnell  
 Paul & Elizabeth Giamatti  
 Nancy Giles  
 Lloyd & Kilty Gilmour  
 Bob Glennon  
 Bryan Gmitter  
 Judy Goldman & Michael Pillingner  
 Wendy Goldman  
 Tony Goldwyn & Jane Musky  
 Fred & Nancy Goodman  
 Stephen & Cathy Graham  
 Connie Grappo & Lee Wilkof  
 Michael Greif & Jonathan Fried  
 Mary Grieco  
 Emily Grishman & Susan Sampliner  
 Lisa Gugenheim  
 Mark & Valerie Hadjipateras  
 James A. Macdonald Foundation  
 Evan Handler  
 Lynn E. Harris  
 Jane & Jonathan Heine  
 Amy Henkels  
 David Herdrich & Elizabeth Palmer  
 Herdrich  
 Peter Herdrich & Karen Trott  
 William Holtzman & S. Sylvia Shepard  
 Katy Homans & Patterson Sims  
 Barbara Howard  
 Kate Hudson & Chris Robinson  
 Michelle Hurst  
 Dana Ivey  
 Mark Evan Jacobs  
 Sy Jacobs  
 Whitney Scott & Peter Jacobson  
 Linda LeRoy Janklow  
 Macon R. & Michael B. Jessop  
 Amanda Johns  
 Julia A. Johns  
 Andrea Johnson  
 Traci Paige Johnson & Robert Mowen  
 Cherry Jones & Mary O'Connor  
 Larry & Mary Jones  
 Marcy & Max Kahn  
 Maurice Kanbar  
 Eric Karpeles & Mike Sell  
 Ronald Kastner & Vanessa Boeys  
 Lisa A. Kauffman  
 Stephen & Sharon Kepniss  
 Seth & Beth Klarman  
 Alan & Kathryn Klingenstein  
 Joana & Jason Klot  
 Mary Kong  
 Judy Kuhn & David Schwab  
 Roger & Belle Kuhn  
 Lynn Landis  
 Mark Lanow & Joanne Astrow  
 Allan & Nanette Larson  
 Jill Larson  
 Michael P. Lawrence  
 Kate Lear & Jonathan LaPook  
 Mary Ann Lefort  
 Howard Leifman  
 Warren Leight  
 Mitchell Lemsky & Jane Bodle  
 Liza Lerner  
 Becky & Steven Lewis

Joshua Lewis  
 Anna Li  
 Linda Li  
 Mark Linn-Baker & Adrienne Lobel  
 Margo Lion  
 Jessica Lissy  
 Adrienne Lobel & Mark Linn Baker  
 Richard & Susan Lobel  
 John Lyons  
 Grace Lyu-Volkhausen  
 Barry Mackall & Bill Schwinghammer  
 Marsue & Peter MacNicol  
 Greg MacPherson & Jane Perlmutter  
 Rusty Magee & Alison Fraser  
 Wendy Makkena & Bob Krakower  
 Paul & Lauren Mandell  
 Elizabeth Manne  
 Peter Manning & André Bishop  
 Donald Margulies & Lynn Street  
 Richard Marin  
 Ali Marsh  
 Jesse L. Martin  
 Kay Matschullat & Allan Arfa  
 Dave & Alicia Matthews  
 Stephen & Cathy Graham  
 Brigid McCarthy  
 Michael Greif & Jonathan Fried  
 Paul McCrane & Dana Kellin  
 Fran McDormand & Joel Coen  
 William Michael McMahon & Meg  
 McMahon  
 Rick Meese & Dan Lori  
 Richard & Denise Menelly  
 Lynn E. Harris  
 Jane & Jonathan Heine  
 Amy Henkels  
 David Herdrich & Elizabeth Palmer  
 Herdrich  
 Peter Herdrich & Karen Trott  
 William Holtzman & S. Sylvia Shepard  
 Katy Homans & Patterson Sims  
 Barbara Howard  
 Kate Hudson & Chris Robinson  
 Michelle Hurst  
 Dana Ivey  
 Mark Evan Jacobs  
 Sy Jacobs  
 Whitney Scott & Peter Jacobson  
 Linda LeRoy Janklow  
 Macon R. & Michael B. Jessop  
 Amanda Johns  
 Julia A. Johns  
 Andrea Johnson  
 Traci Paige Johnson & Robert Mowen  
 Cherry Jones & Mary O'Connor  
 Larry & Mary Jones  
 Marcy & Max Kahn  
 Maurice Kanbar  
 Eric Karpeles & Mike Sell  
 Ronald Kastner & Vanessa Boeys  
 Lisa A. Kauffman  
 Stephen & Sharon Kepniss  
 Seth & Beth Klarman  
 Alan & Kathryn Klingenstein  
 Joana & Jason Klot  
 Mary Kong  
 Judy Kuhn & David Schwab  
 Roger & Belle Kuhn  
 Lynn Landis  
 Mark Lanow & Joanne Astrow  
 Allan & Nanette Larson  
 Jill Larson  
 Michael P. Lawrence  
 Kate Lear & Jonathan LaPook  
 Mary Ann Lefort  
 Howard Leifman  
 Warren Leight  
 Mitchell Lemsky & Jane Bodle  
 Liza Lerner  
 Becky & Steven Lewis

Herald & Linda Ritch  
 Loree Rodkin  
 David & Anita Rogerson  
 Robin Morse & Gus Rogerson  
 Clifford & Betsy Ross  
 Gaylen Ross  
 Daryl Roth  
 Alexander Roy  
 Mark Saad  
 Steve Sabba  
 Laura Sametz  
 Tim & Lisa Sanford  
 Zeborah Schachtel  
 Stacey Schaffer & Eric Schwartz  
 Karin & Tom Schall  
 Leslie Schine & Nils Nilsen  
 Beth Schneider  
 Maury Schott  
 Ken & Mary Ann Schuster  
 Stefan Selig  
 Jeffrey Seller & Joshua Lehrner  
 Mitchell Semel & Colleen Carroll  
 Alyson Shapero  
 Aaron & Elaine Shapiro  
 Jonathan Sheffer  
 Abby Jo Sigal & Matt Turner  
 Meg Simon  
 Landon Slane  
 Talia Balsam & John Slattery  
 Lois Smith  
 Phillip K. & Gloria W. Smith  
 Abigail Rose Solomon  
 Dr. David Solowjczyk  
 John Steber & Robert Shaffron  
 Jean Stein  
 Ben & Christine Stiller  
 David & Sara Stone  
 Abby Stranahan & Dave Ward  
 Susanna Styron & Darrell Larson  
 Brian Swardstrom  
 & Bonnie Bernstein  
 Daniel Swee  
 Mariko Tada  
 Jay & Rachel Tarses  
 Mary Lou Teel & Peter Freundlich  
 Joan Vail & John Thorne  
 Tracy Thorne & Edmund Lewis  
 Gina Torres  
 Anne Torsiglieri & Michael Bernard  
 Liz Tuocillo  
 Laura Valeroso & David Seidman  
 Josephine Eke & Jason Valk  
 Wendy vanden Heuvel & Brad Coley  
 Ed Vassallo  
 John A. Vassallo  
 John A. Vassilaros & Son, Inc  
 Mary Pat Walsh  
 Borah & Mildred Walton  
 Wendy Wasserstein  
 James Waterston & Line Lillevik  
 Anita Waxman  
 Sally & Lenny Weiss  
 Jane Bolster & Steve Wertimer  
 Carol Whitesides  
 Daniel Wiener  
 Jenny Wiener  
 Michael & Zena Wiener  
 Elizabeth Williams & Joseph Forte  
 Matt Williams & Angelina Fiordellisi  
 Jan Wilson & Saula Cutler  
 Donald Windham  
 Sarah Winkler & Simon Leopold  
 John Woo  
 Joanne Woodward & Paul Newman  
 Bill Wrubel & Jennifer Crittenden  
 Jeffrey & Janine Yass  
 James & Mary Lin Yoshimura  
 Virginia Zakian &  
 Robert Sandberg  
 Stuart Zicherman

The 52nd Street Project presents  
 The 2002 Wiener Family Foundation One-on-Ones

# TEN (MORE) FOR THE ROAD: THE TRAVELING PLAYS



JAMES STEVENSON

AUGUST 22-25, 2002  
 THE ENSEMBLE STUDIO THEATRE  
 549 WEST 52ND ST., NEW YORK CITY

**TEN (MORE)  
FOR THE ROAD:  
THE TRAVELING PLAYS**

*The 2002 Wareham, MA  
One-on-Ones  
August 22-25  
The Ensemble Studio Theatre*

**The 52nd Street Project Staff:**

Gus Rogerson, Artistic Director  
 Carol Ochs, Executive Director  
 John Sheehy, Director of Development and Marketing  
 Megan Sandberg-Zakian, Associate Artistic Director  
 George "X-Acto" Babiak, Production Manager  
 Liz Bell, Director of Education  
 Diana Rojas, Executive Assistant  
 Chris Ceraso, Teen Dean  
 Iris A. Brown, Graphic Designer  
 Mayleen Cancel and Zsuzsa Mysak, Receptionists  
 Interns: Conor Fetting-Smith, Charlotte Howard, Beth McMahon

**Production Staff**

**Composer:** Amy Kohn  
**Set Designer:** Kevin Joseph Roach  
**Lighting Designer:** Kelly Blackwell  
**Costume Designer:**  
 Crystal Thompson  
**Costume Assistant:**  
 Jennifer Tatum Jimenez  
**Sound Designer:** Chris Ryan  
**Sound Operator:** Ray Harold  
**Stage Manager:** Karen Munkel  
**Slide Design Team:**  
 Katherine Lumb, Monty Nicol, Kim  
 Snow, John Steward, Iwona Waluk  
**Prop Design Team:**  
 George Babiak, Liz Bell,  
 Conor Fetting-Smith,  
 Charlotte Howard, Ani Kehr,  
 Cara Marcous, Beth McMahon,  
 Karen Munkel, John Sheehy

**Flyer/Program Illustrations:**

James Stevenson

**Furniture Crew:**

Conor Fetting-Smith, Noel Polanco,  
 Stephen Galimidi

**Prop Crew:**

Charlotte Howard, Beth McMahon,  
 Leah Galimidi, Anthony Mejia

**Load-in and Light-hang Crew:**

Conor Fetting-Smith, Charlotte  
 Howard, Beth McMahon, Tim  
 Gallagher

**House Managers:**

Liz Bell, Karin Schall

**Chefs:**

Christopher Randolph, Bruce  
 MacVittie, Carol Ochs, John Sheehy

**Teen Counselor:**

Noel Polanco

**COOL STUFF ON SALE IN THE LOBBY!**

The Fabulous Flyer Bar . . . \$2.00, \$1.50 & \$1.00  
*and featuring Shel Silverstein's "Fivey and Twoey" logo:*  
 Project T-shirts . . . . . \$12.00  
 Project Tank Tops . . . . . \$12.00  
 Project Caps (NEW design) . . . . . \$15.00  
 Project Mugs (now in BLUE!) . . . . . \$5.00  
 Project Pencil 3-pack (now in RED!) . . . . . \$1.00

Thank you for coming to **TEN FOR THE ROAD!** If you are not on our mailing list (or if your address has changed), please fill out this form and give it to us on your way out or mail it to the address below. We would also like to know if you are interested in becoming a volunteer. We need help in **all areas**, so be sure to fill out the entire form.

**PLEASE ADD ME TO YOUR MAILING LIST:**

8/02

NAME: \_\_\_\_\_

ADDRESS: \_\_\_\_\_

ZIP \_\_\_\_\_

HOME PHONE: \_\_\_\_\_

DAYTIME PHONE: \_\_\_\_\_

E-MAIL ADDRESS: \_\_\_\_\_

MY OCCUPATION: \_\_\_\_\_

MY HOBBIES: \_\_\_\_\_

**YES, I WOULD LIKE TO BE OF HELP. I CAN:**

- |   |   |  |
|---|---|--|
| <input type="checkbox"/> Help load in and out for shows | <input type="checkbox"/> Draw and/or paint  | <input type="checkbox"/> Help kids with homework |
| <input type="checkbox"/> Hang lights                    | <input type="checkbox"/> Help with mailings | <input type="checkbox"/> Teach kids a skill      |
| <input type="checkbox"/> Work on a backstage crew       | <input type="checkbox"/> Do office work     | <input type="checkbox"/> Be a chef at an event   |
| <input type="checkbox"/> Do graphic design              | <input type="checkbox"/> Design sound       | <input type="checkbox"/> Design and sew costumes |
| <input type="checkbox"/> Other (please specify) _____   |   |  |

**MY SCHEDULE IS:**

- Very flexible. I'm often available during weekdays.  
 Somewhat flexible. I can help on the occasional morning or afternoon during the week.  
 Not very flexible at all, but I've got some free time on evenings and weekends.

If you would like to mail this (and you're always welcome to enclose a tax-deductible contribution), you can send it to: **The 52nd Street Project**, 500 West 52nd St., New York, NY 10019. Or fax it to (212) 333-5598.



The One-on-Ones Program is made possible with public funds from the National Endowment for the Arts; The New York State Council on the Arts, a state agency; the Department of Youth and Community Development; and the New York City Department of Cultural Affairs. The 52nd Street Project is a member of Art/NY and a participant in the New Generations Program, funded by Doris Duke Charitable Foundation/The Andrew W. Mellon Foundation and administered by Theatre Communications Group, the national organization for the American Theater.



## Don't Miss Our Upcoming Shows!

November 1-3, 2002:  
The Annual Playback Show

*If Only...*

*The Second Chance Plays*

First a kid writes a short play. Then, an adult writes an "answer" play. Then, the two of them perform both plays. Multiply this equation by seven and you've got an entire show.

December 13-15, 2002:  
The Fall  
Playmaking Series



In September, 10 kids brand-new to the Project will begin a Playmaking class taught by Project Playmaking Director Megan Sandberg-Zakian. Come and see their final plays performed by adult professional actors.

The 52nd Street Project is a non-profit organization that brings children from the Hell's Kitchen neighborhood together with professional theater artists to create original theater. **TEN FOR THE ROAD** is a production of our One-on-One program, which is designed to give children the opportunity to go away for one-week stays in the country and enjoy the undivided attention of a professional theater artist who serves as friend, mentor, and collaborator. The Project is delighted to return to the Ensemble Studio Theatre, where we have been performing since our inception in 1981. We gratefully acknowledge the fact that if E.S.T. wasn't here, we'd be nowhere.

### The 52nd Street Project Board of Directors

Ben Barenholtz

Lisa Benavides

Rachel Chanoff

Cathy Dantchik

Noël Dawkins

Wendy Ettinger,

*chair emeritus*

Louis P. Friedman

Stephen Graham, *chair*

Larry Jones

James McDaniel

Frances McDormand

Patricia M. Murphy, Esq.

Carol Ochs

Willie Reale,

*founder*

Gus Rogerson

Shirley Rumierk,

*alumni member*

José Soto, Jr.,

*alumni member*

Pamala Tyson

Laura Valeroso

Wendy vanden Heuvel

John A. Vassilaros

Jenny Wiener

### Special Thanks

Our Host Families – **Gerry & Sam Gray; Anne & Colin McNay; Emily & John Morgan; Susanne & John Potts; Sidney Worthen & David Pearce; Joe & Beth McNay;** and an extra large helping of gratitude for our headquarters hosts **Peter, Helen & Christopher Randolph.**

### In-Kind Contributions

Sincere thanks to our chef **Christopher Randolph** for slaving away over a hot stove; to **David Sneddon, Steve Jenkins & Fairway** for contributing a vanload of great food; **Nesserella's Fruit and Vegetable Stand; Kim D. Sherman** for her musical contributions; **Karin Schall; Stephen Graham;** and the **Marion General Store.**



## TEN (MORE) FOR THE ROAD – ACT I

*“Ten (More) for the Road Theme Song”* lyrics by John Sheehy

### BIG JOHN

Written By Michael Bernard & Directed by Shirley Rumierk  
for **Wonkezeh Newenle**, age 14

Big John .....Wonkezeh Newenle  
Sheriff Luwanda/Grandma .....Shirley Rumierk

*“Drift & Roll”* music by Amy Kohn & lyrics by Michael Bernard

### OZ AGAIN

Written by Suzen Murakoshi & Willie Reale & Directed by Suzen Murakoshi  
for **Evelyn Nicole Rosario**, age 11

Dorothy .....Suzen Murakoshi  
Myrna, The Wicked Witch of the South .....Evelyn Nicole Rosario

*“Newark, Newark”* music by Amy Kohn & lyrics by Willie Reale

### JUST THE CASH

Written by Joe Mihalow & Directed by Tom Schall  
for **Ariana Casablanca**, age 13

Newsman/Headquarters .....John Sheehy  
Customer .....Diana Rojas  
Bank Teller .....Noel Polanco  
Fifi .....Ariana Casablanca  
Francois .....Tom Schall  
Bakery Employee .....Conor Fetting-Smith  
The Boot .....George Babiak

*“Do What You Do”* music by Amy Kohn & lyrics by John Sheehy

### ON THE ROAD, THE PREQUEL

Written & Directed by Bruce MacVittie for **Alex Kehr**, age 11

Dean .....Alex Kehr  
Sal .....Bruce MacVittie  
Hep Cat Chorus .....The “Beat-elles”

*“The Dean Moriarty Riff”* music by Amy Kohn & lyrics by Bruce MacVittie

*“Let’s Step Out”* music by Kim D. Sherman & lyrics by Bruce MacVittie

### THE MAD EXPERIMENT

Written & Directed by Zabryna Guevara for **Anastasia Kehr**, age 12

Mad Scientist .....Anastasia Kehr  
Monster .....Zabryna Guevara

*“Mad Scientist Blues”* music & lyrics by Zabryna Guevara *“Friendship, Life & Truth”* music by Kim D. Sherman & lyrics by Zabryna Guevara

## ACT II

### GROUND CREW GARY TAKES OFF

Written & Directed by Josh Lewis for **Michael Velez**, age 12

Ground Crew Gary .....Michael Velez  
Sparky/Ulcer .....Josh Lewis  
Devon .....Noel Polanco

*“Ground Crew Gary”* music & lyrics by Josh Lewis

### CLOWN TIME IS OVER

Written by Cynthia Kaplan & Directed by Angel Desai  
for **Katie Grullon**, age 12

Petaluna .....Katie Grullon  
Chickie .....Angel Desai  
Circus Announcer .....John Sheehy

*“Out There In The World”* music by Angel Desai & lyrics by Cynthia Kaplan

*“Not An Easy Life”* music by Amy Kohn & lyrics by Cynthia Kaplan

### UP IN ARMS

Written & Directed by Jerry McGill for **Johanna Vidal**, age 11

Lucia Cappuccini .....Johanna Vidal  
Antonio Cappuccini .....Jerry McGill  
Rosaria .....Diana Rojas  
The Couple .....Conor Fetting-Smith, Charlotte Howard  
Sergio .....Noel Polanco

*“I Gotta Have You, You Gotta Have Me”* music by Jerry McGill & Amy Kohn & lyrics by Jerry McGill

### MACK AND MAY

Written & Directed by Keira Naughton for **Zebulun Santiago**, age 11

Mack .....Zebulun Santiago  
May .....Keira Naughton  
Doc .....John Sheehy  
Lady .....Leah Galimidi

*“Mack’s Song”* & *“Mack & May’s Song”* music & lyrics by Keira Naughton

### THE PAINTER

Written & Directed by Robert Sean Leonard for **Mike Grullon**, age 13

Giuseppe .....Mike Grullon  
Paolo .....Robert Sean Leonard  
The Chicken Lady .....Charlotte Howard

*“Giuseppe’s Song”* music & lyrics by Robert Sean Leonard

👉 **Intermission!** 👈

Barker Welfare Foundation, Blythmour Corporation, Capital Research Company, Carnegie Corporation of New York, Comedy Central, Davis Polk & Wardwell, Deutsche Bank of Americas Foundation, The Dramatists Guild Fund, Dramatists Play Service, Eleanor, Adam & Mel Dubin Foundation, Entertainment Weekly, The Fan Fox & Leslie R. Samuels Fdn., The J. Paul Getty Trust, Office of Assembly Member Richard Gottfried, The Horace W. Goldsmith Foundation, Holland Lodge Foundation, Inc., Betty E. & George B. Kaiser Foundation, Lemle Pictures, Inc., Lloyds TSB Bank plc, Lucille Lortel Foundation, Lucent Technologies, James A. Macdonald Foundation, Major League Baseball, Mellon Bank, N.A., The Cynthia & George Mitchell Foundation, The National Board of Review, Newman's Own, The New World Foundation, The New York Times Co. Foundation, Paramount Pictures, Pfizer Foundation, Philip Morris Companies, Roulette Entertainment, Rytech Inc., St. James' Church, Susquehanna Partners, G.P., Theatre Communications Group, Inc., John A. Vassilaros & Son, Inc., The Vervane Foundation, West Bank Café, Felix Zarembo & Co. Inc. (List current as of 10/31/02)

Jace Alexander & Maddie Corman  
 Cecilia Arana-Grant & Kevin Grant  
 Lucie Amaz & Laurence Luckinbill  
 Debbon Ayer  
 June Ballinger & Michael Goldstein  
 Arija Bareikis  
 Ben Barenholtz  
 Benny Bartley  
 Jessica Bauman  
 Laurie Becker & Rick Sweren  
 Gregory Bello  
 Lisa Benavides & Tim Nelson  
 Vicky Bijur & Ed Levine  
 Lewis Black  
 Richard Blackstone & Yldeez Yuksek  
 Tessa Blake  
 Buzz Bovshov  
 Julie Boyd  
 Bob Boyett  
 Becky Browder & Ted Neustadt  
 Susan Bruce & Peter Hedges  
 Michael Buchanan  
 Phoebe Cates & Kevin Kline  
 Alfred C. Cerullo III  
 Rachel Chanoff  
 Sharon Chantile  
 Glenda Chesshir  
 Kirk & Katherine Holt Citron  
 Darah Cloud & Dave Owens  
 Ethan Coen & Trish Cooke  
 Ruth Cohen  
 Lieta Hesen-Cohen & Richard Cohn  
 Elizabeth Cooper Davis  
 & Gordon J. Davis  
 David Copeland  
 Hyla & Richard Crane  
 Margaret Crimmins  
 Peter & Barbara Cross  
 Emily Crow  
 Catherine Curtin  
 Willem Dafoe & Liz Lecompte  
 Nadia Dajani  
 Arthur Dantchik  
 Cathy Dantchik  
 Peter & Judith Dawkins  
 Noël Dawkins & Joe Mihalow  
 Georgia & William Delano  
 Jonathan Demme  
 Stephen DeRosa  
 Cameron Diaz  
 Buddy Dikman & Chuck Davis  
 Alex Draper & Lorraine Tobias  
 Richard & Rebecca Dresser  
 Moira Driscoll & David Pence  
 Christopher & Karen Eddowes  
 Mario Egozi  
 David Eigenberg  
 Ned Eisenberg & Patricia Dunnock  
 Beth Emelson  
 Nora Ephron  
 Barbara Ettinger & Sven Huseby  
 Heidi Ettinger  
 Wendy Ettinger & Derek McLane

Tom Feeney & Paul Parzuchowski  
 Peter Jay Fernandez & Denise Burse  
 Martin Ross Fetner  
 Angelina Fiordellisi & Matt Williams  
 Anita Flanagan & Jeff Potter  
 Alexa Fogel  
 Frank Frattaroli  
 Katherine Freedman  
 Naomi Freundlich & Charles Miles  
 Louis & Patrice Friedman  
 Michael & Sonya Gaffney  
 Janeanne Garofalo  
 Rose Gasner & Larry Chertoff  
 Jonathan Gazdak  
 Cora Cahan & Bernard Gersten  
 Jilian Cahan Gersten  
 Ileen Getz & Mark Grinnell  
 Paul & Elizabeth Giamatti  
 Toni Giamatti  
 Nancy Giles  
 Lloyd & Kity Gilmour  
 Bryan Gmitter  
 Judy Goldman & Michael Pillingier  
 Tony Goldwyn & Jane Musky  
 Fred & Nancy Goodman  
 Lizzie Gottlieb  
 Stephen & Cathy Graham  
 Michael Greif & Jonathan Fried  
 Emily Grishman & Susan Sampliner  
 Lisa Gugenheim  
 Mark & Valerie Hadjipateras  
 Lynn E. Harris  
 Jane & Jonathan Heine  
 Peter Herdrich & Karen Trott  
 Colleen Hindsley  
 William Holtzman & S. Sylvia  
 Shepard  
 Katy Homans & Patterson Sims  
 Matthew Houston  
 Barbara Howard  
 Philip & Alexandra Howard  
 Kate Hudson & Chris Robinson  
 Dana Ivey  
 Mark Evan Jacobs  
 Whitney Scott & Peter Jacobson  
 Amanda Johns  
 Andrea Johnson  
 Traci Paige Johnson  
 & Robert Mowen  
 Larry & Mary Jones  
 Maurice Kanbar  
 Eric Karpeles & Mike Sell  
 Ronald Kastner & Vanessa Boeyle  
 Stephen & Sharon Kepniss  
 Judy Kuhn & David Schwab  
 Roger & Belle Kuhn  
 Allan & Nanette Larson  
 Michael P. Lawrence  
 Kate Lear & Jonathan LaPook  
 Mary Ann Lefort  
 Warren Leight  
 Robert Sean Leonard  
 Liza Lerner

Aimee Levine  
 Joshua Lewis  
 Anna Li  
 Linda Li  
 Adrienne Lobel & Mark Linn Baker  
 John Lyons  
 Grace Lyu-Volkhausen  
 Barry Mackall  
 & Bill Schwinghammer  
 Marsue & Peter MacNicol  
 Greg MacPherson  
 & Jane Perlmutter  
 Roma Maffia  
 Rusty Magee & Alison Fraser  
 Wendy Makkena & Bob Krakower  
 Elizabeth Manne  
 Donald Margulies & Lynn Street  
 Richard Marin  
 Sonya Martin  
 John Matoian  
 Kay Matschullat & Allan Arffa  
 Brigid Mccarthy  
 Fran McDormand & Joel Coen  
 Jerry McGill  
 William Michael McMahon  
 & Meg McMahon  
 Rick Meese & Dan Lori  
 Richard & Denise Menelly  
 Josie Merck & Jim Stevenson  
 Audrey & Danny Meyer  
 Nancy Meyer & Marc Weiss  
 Emily & John Morgan  
 Alfred H. Morris  
 Bob Morris  
 Meg Mortimer  
 Suzen Murakoshi  
 Patricia M. Murphy, Esq.  
 & Adam Spilka  
 Geoffrey Naultfs  
 Eric Nedelander  
 Don & Sara Nelson  
 Pamela & Peter Nelson  
 Randy & Rona Nelson  
 Ruth Nelson  
 Mark Nesselson, M.D.  
 & Elliott Rosenblum  
 Lori O'Connor  
 Kevin O'Rourke & Edith Thurber  
 Carol Ochs & Bruce MacVittie  
 Jacki Ochs & Jan Kroezee  
 Lenore Pemberton  
 Elizabeth Peters  
 Peter & Ana Rosa Phillips  
 Oliver Platt & Camilla Campbell Platt  
 Jeremy Posner  
 Dean & Leslie Potashner  
 Michael Potts  
 Christopher Randolph  
 Peter & Helen Randolph  
 Richard Rauchenberger  
 Willie Reale & Jenny Gersten  
 Theresa Rebeck & Jess Lynn  
 Herald & Linda Ritch

David & Anita Rogerson  
 Robin Morse & Gus Rogerson  
 Arthur H. Rosenbloom  
 Daryl Roth  
 Alexander Roy  
 Shirley Rumiark  
 Mark Saad  
 Steve Sabba  
 Arnold & Agnes Sametz  
 Laura Sametz  
 Elizabeth Santeix  
 Zeborah Schachtel  
 Karin & Tom Schall  
 Leslie Schine & Nils Nilsen  
 Maury Schott  
 Ken & Mary Ann Schuster  
 Richard Schwartz  
 Dana Segal  
 Stefan Selig  
 Mitchell Semel & Colleen Carroll  
 Richard Shaffer & Nataalka Bukalo  
 Aaron & Elaine Shapiro  
 Bernice Baruch Shawl  
 Abby Jo Sigal & Matt Turner  
 Meg Simon  
 Landon Slane  
 Talia Balsam & John Slattery  
 Abigail Rose Solomon  
 Jean Stein  
 Ben & Christine Stiller  
 David & Sara Stone  
 Abby Stranahan & Dave Ward  
 Paola Styron  
 Susanna Styron & Darrell Larson  
 Brian Swardstrom  
 & Bonnie Bernstein  
 Daniel Swee  
 Mariko Tada  
 Crystal Thompson  
 Gina Torres  
 Anne Torsiglieri & Michael Bernard  
 Carl & Edna Torsiglieri  
 Liz Tuccillo  
 John & Katherine Turturro  
 Laura Valeroso & David Seidman  
 Josephine Eke & Jason Valk  
 Wendy vanden Heuvel & Brad Coley  
 Ed Vassallo  
 John A. Vassallo  
 Susan Vitucci  
 Mary Pat Walsh  
 Borah & Mildred Walton  
 Maja Wampuszyc  
 Wendy Wasserstein  
 Anita Waxman  
 Ann & Paul Weiss  
 Sally & Lenny Weiss  
 Jane Bolster & Steve Wertimer  
 Carol Whitesides  
 Jenny Wiener & Jon Steingart  
 Michael & Zena Wiener  
 Donald Windham

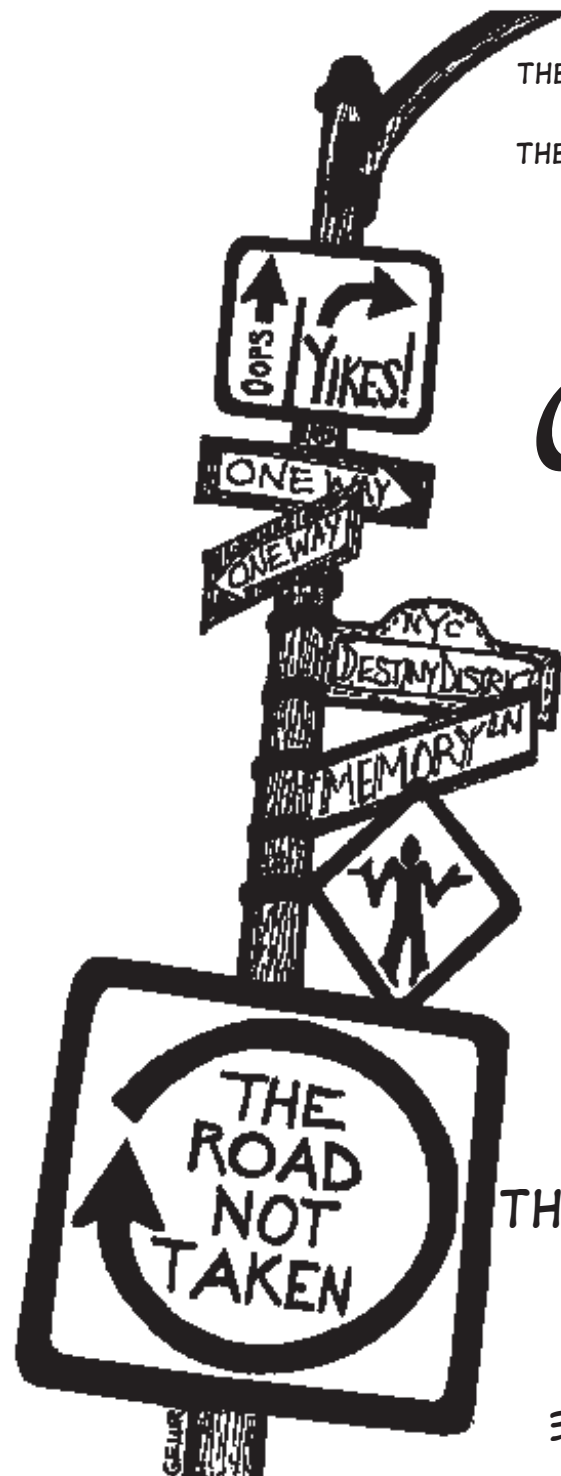

THE 52ND STREET PROJECT  
 PRESENTS  
 THE 2002 PLAYBACK SERIES

# IF ONLY...

## THE SECOND CHANCE PLAYS

FRI., NOV. 1  
 AT 7:30 P.M.

SAT., NOV. 2  
 AT 3:00 P.M.  
 & 7:30 P.M.

SUN., NOV. 3  
 AT 3:00 P.M.

THE CHERNUCHIN  
 THEATER AT  
 A.T.A.  
 314 W. 54TH ST.,  
 NEW YORK CITY

# IF ONLY...

THE SECOND CHANCE PLAYS

THE 2002  
PLAYBACK SERIES  
NOVEMBER 1-3  
AT A.T.A.

**The 52nd Street Project Staff:**

Gus Rogerson, Artistic Director  
 Carol Ochs, Executive Director  
 John Sheehy, Director of Development and Marketing  
 Megan Sandberg-Zakian, Associate Artistic Director  
 George "X-Acto" Babiak, Production Manager  
 Liz Bell, Director of Education  
 Diana Rojas, Executive Assistant  
 Chris Ceraso, Teen Dean  
 Iris A. Brown, Graphic Designer  
 Mayleen Cancel and Jaymaree Rosado, Receptionists  
 Interns: Jolie Tong and Padma Sundaram

**Production Staff:**

**Composer:** Joel Derfner  
**Music Director:** Kari Riely  
**Set Designer:** Kevin Joseph Roach  
**Lighting Designer:**  
 Greg MacPherson  
**Assistant Lighting Designer:**  
 Jason Wells  
**Costume Designer:** Sheila Kehoe  
**Sound Designer:** Betsy Rhodes  
**Stage Manager:** Noël Dawkins  
**Slide Designers:**  
 George Babiak, Christopher  
 Bonanos, Katherine Lumb, Monty  
 Nicol, John Steward, Iwona Waluk  
**"If Only" Illustration:**  
 Esther Geller  
**Prop Design Team:**  
 George Babiak, Roi Babiak,

Danny Goldstein, Amanda Keropian,  
 Cara Marcous, Karen Munkel,  
 Padma Sundaram, Jolie Tong  
**Furniture Crew:**  
 Lee Rosen, Zebulon Santiago,  
 Adrian Zambrano and Alex Tomas  
**Prop Crew:**  
 Jolie Tong, Padma Sundaram,  
 Johanna Vidal  
**Load-in and Light Hang Crew:**  
 Jack Gwaltney, Karen Munkel, Moira  
 MacDonald, Anne O'Sullivan,  
 Christopher Randolph, Chris Ryan,  
 John Salzman, Tom Schall, Maury  
 Schott, Charlie Tolkentines  
**House Managers:** Liz Bell,  
 Karin Schall, and Mary Pat Walsh  
**Chefs:** John Sheehy, Liz Bell



The Playback Program is made possible with public funds from the National Endowment for the Arts; The New York State Council on the Arts, a state agency. The 52nd Street Project is a member of Art/NY and a participant in the New Generations Program, funded by Doris Duke Charitable Foundation/The Andrew W. Mellon Foundation and administered by Theatre Communications Group, the national organization for the American Theater.



# COOL STUFF ON SALE!

FLYER BARS . . . \$2.00, \$1.50 & \$1.00  
 SHEL SILVERSTEIN'S "FIVEY AND TWOEY" LOGO

**GEAR:**

PROJECT T-SHIRTS . . . . . \$12.00  
 PROJECT LONG SLEEVE T-SHIRTS \$15.00  
 PROJECT CAPS . . . . . \$15.00  
 PROJECT MUGS . . . . . \$5.00  
 PROJECT PENCIL 3-PACK . . . . . \$1.00

Thank you for coming to **IF ONLY...** If you are not on our mailing list (or if your address has changed), please fill out this form and give it to us on your way out or mail it to the address below. We would also like to know if you are interested in becoming a volunteer. We need help in **all areas**, so be sure to fill out the entire form.

**PLEASE ADD ME TO YOUR MAILING LIST:**

11/02

NAME: \_\_\_\_\_

ADDRESS: \_\_\_\_\_

\_\_\_\_\_ ZIP \_\_\_\_\_

HOME PHONE: \_\_\_\_\_

DAYTIME PHONE: \_\_\_\_\_

E-MAIL ADDRESS: \_\_\_\_\_

MY OCCUPATION: \_\_\_\_\_

MY HOBBIES: \_\_\_\_\_

**YES, I WOULD LIKE TO BE OF HELP. I CAN:**

- |   |   |  |
|---|---|--|
| <input type="checkbox"/> Help load in and out for shows | <input type="checkbox"/> Draw and/or paint  | <input type="checkbox"/> Help kids with homework |
| <input type="checkbox"/> Hang lights                    | <input type="checkbox"/> Help with mailings | <input type="checkbox"/> Teach kids a skill      |
| <input type="checkbox"/> Work on a backstage crew       | <input type="checkbox"/> Do office work     | <input type="checkbox"/> Be a chef at an event   |
| <input type="checkbox"/> Do graphic design              | <input type="checkbox"/> Design sound       | <input type="checkbox"/> Design and sew costumes |
| <input type="checkbox"/> Other (please specify) _____   |   |  |

**MY SCHEDULE IS:**

- Very flexible. I'm often available during weekdays.  
 Somewhat flexible. I can help on the occasional morning or afternoon during the week.  
 Not very flexible at all, but I've got some free time on evenings and weekends.



If you would like to mail this (and you're always welcome to enclose a tax-deductible contribution), you can send it to: **The 52nd Street Project**, 500 West 52nd St., New York, NY 10019. Or fax it to (212) 333-5598.

**Don't Miss Our Upcoming Shows!**

# STOP THE PRESSES!



**December 13-15**  
**HB Playwright's**  
**Foundation**  
**124 Bank St.**

In September, 10 kids brand-new to the Project began a Playmaking class taught by Playmaking Director Megan Sandberg-Zakian. Come and see their final plays performed by adult professional actors.

## ***THE SENSATIONAL PLAYS***

**"IF AT FIRST  
YOU DON'T  
SUCCEED..."**

**PLAYS THAT TRY AGAIN**

*PLAYBACK, ROUND II*  
*JANUARY, 2003*

We're doing it again, but with new kids, new adults, new plays, and a new theater...not to mention a new theme. Come see it!

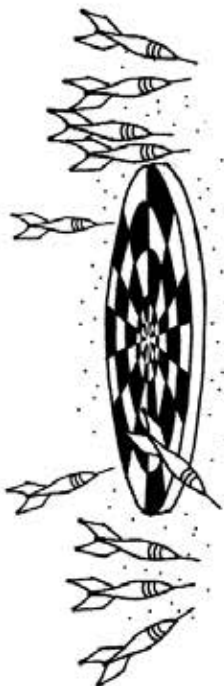

The 52nd Street Project is a non-profit organization that brings children from the Hell's Kitchen neighborhood together with professional theater artists to create original theater. **IF ONLY...** is a production of our Playback program, in which kid actor/playwrights are taken away for a weekend in Pawling, New York, where they write a play. Their adult actor/playwright partners then write "answer plays" in response. In the final production, which you see here tonight, the partners perform both plays back-to-back. All of the kids involved are veterans of the Playmaking classes which were adapted for the Project by Daniel Judah Sklar from his book *Playmaking: Children Writing and Performing Their Own Plays*.

### **The 52nd Street Project Board of Directors**

Ben Barenholtz  
Lisa Benavides  
Rachel Chanoff  
Cathy Dantchik  
Noël Dawkins  
Wendy Ettinger,  
*chair emeritus*  
Louis P. Friedman  
Stephen Graham, *chair*  
Larry Jones  
James McDaniel  
Frances McDormand  
Patricia M. Murphy, Esq.

Carol Ochs  
Willie Reale,  
*founder*  
Gus Rogerson  
Shirley Rumierk,  
*alumni member*  
José Soto, Jr.,  
*alumni member*  
Pamala Tyson  
Laura Valeroso  
Wendy vanden Heuvel  
John A. Vassilaros  
Jenny Wiener

### **Special Thanks**

We're extremely grateful to **Sharon Washington, Charles Ward, Craig the caretaker**, and the **Hudson Valley Artist's Foundation** for housing us over the Playback writing weekend. Thanks also to **Anita Flanagan** for her help with costumes.

### **In-Kind Contributions**

We are also indebted to **Neil A. Mazzella and Hudson Scenic Studios**; the **Murphy Law Office**; **Iris A. Brown**; **Ron Kastner and Capital Printing**; **Big Apple Lights**; **Coleman**; **Noggin**; **The Printing Store**; **Scholastic, Inc.**; **Diageo Chateau & Estate Wines**; **Sesame Workshop**; **Watkins, Inc.**; **Mayor's Office of Film & Television**; **Boylan's Bottling Co.**; **David Sneddon & Fairway Market**; **Andy Millon**; **Steve Olsen & The Westbank Cafe**; **Lorraine Tobias & Imaginary Studios**; **Robert Goldberg and Yorke Construction**; **Jive Records**, part of **Zomba Music Group**; and **Prime Films**.

## IF ONLY... ACT I

All original music composed by Joel Derfner

### Stealing Dreams

By Steven Vasquez age 15. Dramaturg/Director: Ed Vassallo

### The Playuh-Hatuh

 Written and directed by Ed Vassallo

Benchy .....Steven Vasquez  
The Shaker .....Ed Vassallo  
Coach .....John Sheehy  
B.B. Players .....The Crew  
Announcers/Reporters .....Gus Rogerson, John Sheehy, George Babiak  
“*Benchy’s Rap*” lyrics by Ed Vassallo

---

### Beginning is Winning, Losing’s the End

By Lizette Natera, age 14. Dramaturg/Director: Megan Sandberg-Zakian

### I’m Okay, You’re Serving Coffee

Written by Susan Kim, directed by Megan Sandberg-Zakian

D.J. Smith .....Lizette Natera  
Brittany Santiago .....Cecilia Arana  
Teacher .....Padma Sundaram  
Adoring Fan .....Johanna Vidal  
“*All for You*” and “*I Got to Go*” lyrics by Lizette Natera. “*I Got to Go 2*” lyrics by Susan Kim.

---

### The Line Between Friends

By Robert Tomas, age 14. Dramaturg/Director: Michael Potts

### A Few Good Years Left

 Written and directed by Michael Potts

Jose/Coach Hector Lopez .....Robert Tomas  
Bryan/Principal Joe Johnson .....Michael Potts  
Girls at Party .....Liz Bell, Padma Sundaram  
Partygoers .....The Crew  
“*You Can Count on a Friend*” lyrics by Robert Tomas

---

### Through Thick and Thin

By Jaymaree Rosado, age 15. Dramaturg/Director: Liz Flahive

### The Real News

 Written and directed by Liz Flahive

Julia/Janice .....Jaymaree Rosado  
Jobe/Ed Edwards .....Duane Boutté  
Lady/Ed’s Mother .....Kari Riely  
The Judges .....Gus Rogerson, John Sheehy, George Babiak

👉 **Intermission!** 👈

## IF ONLY... ACT II

### Friends are Better than Fame

By Oscar Padilla, age 15. Dramaturg/Director: Danny Goldstein

### Tennis, Gilly-Style

Written and Directed by Danny Goldstein

Gilly Thom-Son/Jack .....Oscar Padilla  
Tina White/Diane .....Roz Coleman  
Director .....John Sheehy  
Cameraman .....Alex Tomas  
Writer .....Zebulon Santiago  
Clapper Girl .....Johanna Vidal  
Guy in street .....Adrian Zambrano  
“*Smelly Slob*” and “*Give Some Gratitude*” lyrics by Oscar Padilla

---

### Liz and Iz

By Nadya Jabour, age 14. Dramaturg/Director: Nancy Giles

### Love and Biz

Written and Directed by Nancy Giles

Elizabeth .....Nadya Jabour  
Isabella/Dr. Van Pelt .....Nancy Giles  
“*Remember the Days*” lyrics by Nancy Giles

---

### Two Different Ways

By Justin Aponte, age 15. Dramaturg/Director: Gus Rogerson

### Rien de Rien

Written and directed by Gus Rogerson

Tom .....Justin Aponte  
Ray .....Gus Rogerson  
French Painter .....George Babiak  
“*Nowhere to Go*” lyrics by Gus Rogerson

## Teen Glossary

**a’ight** or **lght**- A contraction of “all right.”

**buggin’** or **trippin’**- Crazy, irrational

**chill**- Take it easy, stop.

**dum** or **mad**- Extremely, very

**fashizzle**- For sure, definitely.

**frontin’**- Putting on a false image.

“**G**” or “**son**”- Terms of affection

**hater**- A person who is very critical

**heated**- Angry, upset

**I’m out** or “**one**”- Goodbye

**keep it global, keep it gator**- Stay calm, take it easy.

**off the hook**- Superlative, beyond measurable limits

**PJ’s**- The projects (housing developments)

**wack**- Nerdy, uncool

**what’s good? what’s poppin’**- How is everything with you?

**word** or **ya heard?**- Yes, absolutely

Barker Welfare Foundation, Blythmour Corporation, Capital Research Company, Carnegie Corporation of New York, Comedy Central, Davis Polk & Wardwell, Deutsche Bank of Americas Foundation, The Dramatists Guild Fund, Dramatists Play Service, Eleanor, Adam & Mel Dubin Foundation, Entertainment Weekly, The Fan Fox & Leslie R. Samuels Fdn., The J. Paul Getty Trust, Office of Assembly Member Richard Gottfried, The Horace W. Goldsmith Foundation, Holland Lodge Foundation, Inc., Betty E. & George B. Kaiser Foundation, Lemle Pictures, Inc., Lloyds TSB Bank plc, Lucille Lortel Foundation, Lucent Technologies, James A. Macdonald Foundation, Major League Baseball, Mellon Bank, N.A., The Cynthia & George Mitchell Foundation, The National Board of Review, Newman's Own, The New World Foundation, The New York Times Co. Foundation, Paramount Pictures, Pfizer Foundation, Philip Morris Companies, Roulette Entertainment, Rytech Inc., St. James' Church, Susquehanna Partners, G.P., Theatre Communications Group, Inc., John A. Vassilaros & Son, Inc., The Vervane Foundation, West Bank Café, Felix Zarembo & Co. Inc. (List current as of 10/31/02)

Jace Alexander & Maddie Corman  
 Cecilia Arana-Grant & Kevin Grant  
 Lucie Amaz & Laurence Luckinbill  
 Debbon Ayer  
 June Ballinger & Michael Goldstein  
 Arija Bareikis  
 Ben Barenholtz  
 Benny Bartley  
 Jessica Bauman  
 Laurie Becker & Rick Sweren  
 Gregory Bello  
 Lisa Benavides & Tim Nelson  
 Vicky Bijur & Ed Levine  
 Lewis Black  
 Richard Blackstone & Yldeez Yuksek  
 Tessa Blake  
 Buzz Boydshow  
 Julie Boyf  
 Bob Boyett  
 Becky Browder & Ted Neustadt  
 Susan Bruce & Peter Hedges  
 Michael Buchanan  
 Phoebe Cates & Kevin Kline  
 Alfred C. Cerullo III  
 Rachel Chanoff  
 Sharon Chantile  
 Glenda Chesshir  
 Kirk & Katherine Holt Citron  
 Darah Cloud & Dave Owens  
 Ethan Coen & Trish Cooke  
 Ruth Cohen  
 Lieta Hesen-Cohen & Richard Cohn  
 Elizabeth Cooper Davis  
 & Gordon J. Davis  
 David Copeland  
 Hyla & Richard Crane  
 Margaret Crimmins  
 Peter & Barbara Cross  
 Emily Crow  
 Catherine Curtin  
 Willem Dafoe & Liz Lecompte  
 Nadia Dajani  
 Arthur Dantchik  
 Cathy Dantchik  
 Peter & Judith Dawkins  
 Noël Dawkins & Joe Mihalow  
 Georgia & William Delano  
 Jonathan Demme  
 Stephen DeRosa  
 Cameron Diaz  
 Buddy Dikman & Chuck Davis  
 Alex Draper & Lorraine Tobias  
 Richard & Rebecca Dresser  
 Moira Driscoll & David Pence  
 Christopher & Karen Eddowes  
 Mario Egozi  
 David Eigenberg  
 Ned Eisenberg & Patricia Dunnock  
 Beth Emelson  
 Nora Ephron  
 Barbara Ettinger & Sven Huseby  
 Heidi Ettinger  
 Wendy Ettinger & Derek McLane

Tom Feeney & Paul Parzuchowski  
 Peter Jay Fernandez & Denise Burse  
 Martin Ross Felner  
 Angelina Fiordellisi & Matt Williams  
 Anita Flanagan & Jeff Potter  
 Alexa Fogel  
 Frank Frattaroli  
 Katherine Freedman  
 Naomi Freundlich & Charles Miles  
 Louis & Patrice Friedman  
 Michael & Sonya Gaffney  
 Janeanne Garfalo  
 Rose Gasner & Larry Chertoff  
 Jonathan Gazdak  
 Cora Cahan & Bernard Gersten  
 Jilian Cahan Gersten  
 Ileen Getz & Mark Grinnell  
 Paul & Elizabeth Giamatti  
 Toni Giamatti  
 Nancy Giles  
 Lloyd & Kity Gilmour  
 Bryan Gmitter  
 Judy Goldman & Michael Pillingier  
 Tony Goldwyn & Jane Musky  
 Fred & Nancy Goodman  
 Lizzie Gottlieb  
 Stephen & Cathy Graham  
 Michael Greif & Jonathan Fried  
 Emily Grishman & Susan Sampliner  
 Lisa Gugenheim  
 Mark & Valerie Hadjipateras  
 Lynn E. Harris  
 Jane & Jonathan Heine  
 Peter Herdrich & Karen Trott  
 Colleen Hindstley  
 William Holtzman & S. Sylvia  
 Shepard  
 Katy Homans & Patterson Sims  
 Matthew Houston  
 Barbara Howard  
 Philip & Alexandra Howard  
 Kate Hudson & Chris Robinson  
 Dana Ivey  
 Mark Evan Jacobs  
 Whitney Scott & Peter Jacobson  
 Amanda Johns  
 Andrea Johnson  
 Traci Paige Johnson  
 & Robert Mowen  
 Larry & Mary Jones  
 Maurice Kanbar  
 Eric Karpeles & Mike Sell  
 Ronald Kastner & Vanessa Boeyle  
 Stephen & Sharon Kepniss  
 Judy Kuhn & David Schwab  
 Roger & Belle Kuhn  
 Allan & Nanette Larson  
 Michael P. Lawrence  
 Kate Lear & Jonathan LaPook  
 Mary Ann Lefort  
 Warren Leight  
 Robert Sean Leonard  
 Liza Lerner

Aimee Levine  
 Joshua Lewis  
 Anna Li  
 Linda Li  
 Adrienne Lobel & Mark Linn Baker  
 John Lyons  
 Grace Lyu-Volkhausen  
 Barry Mackall  
 & Bill Schwinghammer  
 Marsue & Peter MacNicol  
 Greg MacPherson  
 & Jane Perlmutter  
 Roma Maffia  
 Rusty Magee & Alison Fraser  
 Wendy Makkena & Bob Krakower  
 Elizabeth Manne  
 Donald Margulies & Lynn Street  
 Richard Marin  
 Sonya Martin  
 John Matoian  
 Kay Matschullat & Allan Arffa  
 Brigid Mccarthy  
 Fran McDormand & Joel Coen  
 Jerry McGill  
 William Michael McMahon  
 & Meg McMahon  
 Rick Meese & Dan Lori  
 Richard & Denise Menelly  
 Josie Merck & Jim Stevenson  
 Audrey & Danny Meyer  
 Nancy Meyer & Marc Weiss  
 Emily & John Morgan  
 Alfred H. Morris  
 Bob Morris  
 Meg Mortimer  
 Suzen Murakoshi  
 Patricia M. Murphy, Esq.  
 & Adam Spilka  
 Geoffrey Naultifs  
 Eric Nedelander  
 Don & Sara Nelson  
 Pamela & Peter Nelson  
 Randy & Rona Nelson  
 Ruth Nelson  
 Mark Nesselson, M.D.  
 & Elliott Rosenblum  
 Lori O'Connor  
 Kevin O'Rourke & Edith Thurber  
 Carol Ochs & Bruce MacVittie  
 Jacki Ochs & Jan Kroeze  
 Lenore Pemberton  
 Elizabeth Peters  
 Peter & Ana Rosa Phillips  
 Oliver Platt & Camilla Campbell Platt  
 Jeremy Posner  
 Dean & Leslie Potashner  
 Michael Potts  
 Christopher Randolph  
 Peter & Helen Randolph  
 Richard Rauchenberger  
 Willie Reale & Jenny Gersten  
 Theresa Rebeck & Jess Lynn  
 Herald & Linda Ritch

David & Anita Rogerson  
 Robin Morse & Gus Rogerson  
 Arthur H. Rosenbloom  
 Daryl Roth  
 Alexander Roy  
 Shirley Rumiark  
 Mark Saad  
 Steve Sabba  
 Arnold & Agnes Sametz  
 Laura Sametz  
 Elizabeth Santeix  
 Zeborah Schachtel  
 Karin & Tom Schall  
 Leslie Schine & Nils Nilsen  
 Maury Schott  
 Ken & Mary Ann Schuster  
 Richard Schwartz  
 Dana Segal  
 Stefan Selig  
 Mitchell Semel & Colleen Carroll  
 Richard Shaffer & Nataalka Bukalo  
 Aaron & Elaine Shapiro  
 Bernice Baruch Shawl  
 Abby Jo Sigal & Matt Turner  
 Meg Simon  
 Landon Slane  
 Talia Balsam & John Slattery  
 Abigail Rose Solomon  
 Jean Stein  
 Ben & Christine Stiller  
 David & Sara Stone  
 Abby Stranahan & Dave Ward  
 Paola Styron  
 Susanna Styron & Darrell Larson  
 Brian Swardstrom  
 & Bonnie Bernstein  
 Daniel Swee  
 Mariko Tada  
 Crystal Thompson  
 Gina Torres  
 Anne Torsiglieri & Michael Bernard  
 Carl & Edna Torsiglieri  
 Liz Tuccillo  
 John & Katherine Turturro  
 Laura Valeroso & David Seidman  
 Josephine Eke & Jason Valk  
 Wendy vanden Heuvel & Brad Coley  
 Ed Vassallo  
 John A. Vassallo  
 John Vassilaros & Alexandra Gersten  
 Susan Vitucci  
 Mary Pat Walsh  
 Borah & Mildred Walton  
 Maja Wampuszyc  
 Wendy Wassestein  
 Anita Waxman  
 Ann & Paul Weiss  
 Sally & Lenny Weiss  
 Jane Bolster & Steve Wertimer  
 Carol Whitesides  
 Jenny Wiener & Jon Steingart  
 Michael & Zena Wiener  
 Donald Windham

## THE 52ND STREET PROJECT

presents the Fall 2002 Playmaking Series

# STOP THE PRESSES!



## THE SENSATIONAL PLAYS

Fri., Dec. 13 at 7:30 p.m., Sat., Dec. 14 at 3:00 p.m. and 7:30 p.m.  
 and Sun., Dec. 15 at 3:00 p.m.

**HB Playwright's Foundation**

124 Bank St. in the West Village

# STOP THE PRESSES!

The Fall 2002 Playmaking Plays - Dec. 13-15, HB Playwright's Foundation

## The 52nd Street Project Staff:

Gus Rogerson, Artistic Director  
Carol Ochs, Executive Director  
John Sheehy, Director of Development and Marketing  
Megan Sandberg-Zakian, Associate Artistic Director  
George "X-Acto" Babiak, Production Manager  
Liz Bell, Director of Education  
Diana Rojas, Executive Assistant  
Chris Ceraso, Teen Dean  
Iris A. Brown, Graphic Designer  
Mayleen Cancel and Jaymaree Rosado, Receptionists  
Interns: Jolie Tong and Padma Sundaram

## Production Staff

**Composer:** Joel Derfner  
**Set Designer:** Kevin Joseph Roach  
**Lighting Designer:**  
Greg MacPherson  
**Costume Designer:**  
Crystal Thompson  
**Costume Ass't:** Jennifer Jimenez  
**Sound Designer:** Maury Schott  
**Stage Manager:** Karen Munkel  
**Slide Designers:**  
George Babiak, Mike Sell, et al  
**"STP" Illustration:** Mike Sell  
**Prop Design Team:**  
George Babiak, Roi Babiak,  
Heather Carnduff, Cara Marcous,  
Rick Meese, Leigh Pennebaker,  
Jonathan Philips, Adam Robinson,  
John Sheehy, Jolie Tong

**Furniture Crew:**  
Charlie Tocantins, Anthony Mejia  
**Prop Crew:**  
Adam Robinson, Ariana Casablanca  
**Wall Art Crew:**  
Padma Sundaram,  
Solangee Acosta  
**Load-in and Light Hang Crew:**  
Kelly Blackwell, Perry McBain  
Daniel, Doug Nervik, Rudy Katzke,  
Jonathan Philips, Chris Ryan, Mike  
Stone  
**House Managers:** Susan McGinnis,  
Karin Schall, Mary Pat Walsh,  
Liz Bell  
**Hosts:** Eric Karpeles and Mike Sell  
**Chef:** Eric Karpeles  
**Pals:** Eric Karpeles and Mike Sell



NATIONAL  
ENDOWMENT  
FOR THE ARTS

The Playmaking Program is made possible with public funds from the National Endowment for the Arts; The New York State Council on the Arts, a state agency; the Department of Youth and Community Development; and the New York City Department of Cultural Affairs Cultural Challenge Program. The 52nd Street Project is a member of Art/NY and a participant in the New Generations Program, funded by Doris Duke Charitable Foundation/The Andrew W. Mellon Foundation and administered by Theatre Communications Group, the national organization for the American Theater.

State of the Arts



NYSCA

# COOL STUFF ON SALE!

Flyer Bars .....\$2.00, \$1.50 & \$1.00

*Shel Silverstein's "Fivey and Twoey" logo gear:*

Project sweatshirts .....\$20.00

Project long sleeve t-Shirts .....\$15.00

Project Caps .....\$15.00

Project Mugs .....\$5.00

Project Pencil 3-pack .....\$1.00

"Sweet Appreciation" CD .....\$25.00

Thank you for coming to **STOP THE PRESSES**. If you are not on our mailing list (or if your address has changed), please fill out this form and give it to us on your way out or mail it to the address below. We would also like to know if you are interested in becoming a volunteer. We need help in **all areas**, so be sure to fill out the entire form.

## PLEASE ADD ME TO YOUR MAILING LIST:

12/02

NAME: \_\_\_\_\_

ADDRESS: \_\_\_\_\_

\_\_\_\_\_ ZIP \_\_\_\_\_

HOME PHONE: \_\_\_\_\_

DAYTIME PHONE: \_\_\_\_\_

E-MAIL ADDRESS: \_\_\_\_\_

MY OCCUPATION: \_\_\_\_\_

MY HOBBIES: \_\_\_\_\_

## YES, I WOULD LIKE TO BE OF HELP. I CAN:

- |   |   |  |
|---|---|--|
| <input type="checkbox"/> Help load in and out for shows | <input type="checkbox"/> Draw and/or paint  | <input type="checkbox"/> Help kids with homework |
| <input type="checkbox"/> Hang lights                    | <input type="checkbox"/> Help with mailings | <input type="checkbox"/> Teach kids a skill      |
| <input type="checkbox"/> Work on a backstage crew       | <input type="checkbox"/> Do office work     | <input type="checkbox"/> Be a chef at an event   |
| <input type="checkbox"/> Do graphic design              | <input type="checkbox"/> Design sound       | <input type="checkbox"/> Design and sew costumes |
| <input type="checkbox"/> Other (please specify) _____   |   |  |

## MY SCHEDULE IS:

- Very flexible. I'm often available during weekdays.  
 Somewhat flexible. I can help on the occasional morning or afternoon during the week.  
 Not very flexible at all, but I've got some free time on evenings and weekends.

If you would like to mail this (and you're always welcome to enclose a tax-deductible contribution), you can send it to: **The 52nd Street Project**, 500 West 52nd St., New York, NY 10019. Or fax it to (212) 333-5598.

**Don't Miss Our Upcoming Shows!**

# *All Aboard!*

## THE DEPARTURE PLAYS

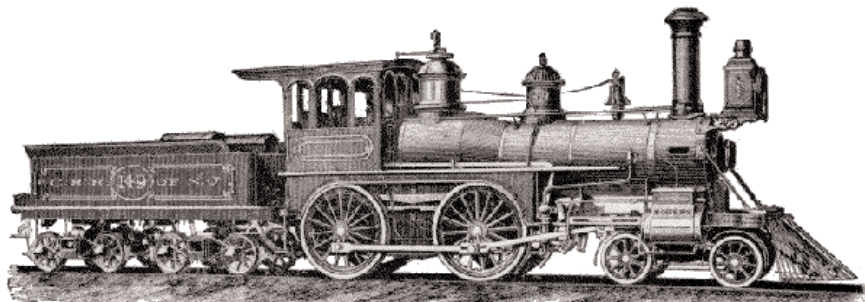

### THE 2003 TWO-ON-TWOS

Feb. 1-3, 2003 at *The Women's Interart Annex*

500 W. 52nd St., #2A (Just across the hall from the Clubhouse)

In the One-on-One's, a single kid is paired with a single adult. Now you can see *two* kids perform a play written by an adult and directed by *another* adult. Call (212) 642-5052 for reservations

# The 2003 Teen Ensemble Sonnet Scenes

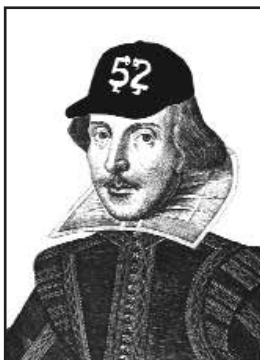

Co-written by William Shakespeare  
and the teens of the 52nd Street Project

Saturday, March 1 at 7:30 p.m. and Sunday, March 2 at 3:00 p.m. at

**The Women's Interart Annex**

Call (212) 333-5252 for reservations.

The 52nd Street Project is a non-profit organization that brings children from the Hell's Kitchen neighborhood together with professional theater artists to create original theater. **STOP THE PRESSES** is a production of our Playmaking program. Young people participate in a nine-week playwriting course taught by Megan Sandberg-Zakian and adapted for the Project by Daniel Judah Sklar from his book *Playmaking: Children Writing and Performing Their Own Plays*. At the end of the course, each child is given two actors, a theme, and a dramaturg/director who guides him or her through the writing of a play during a weekend retreat in the country (Tyler Hill, Pennsylvania, for this show). Tonight's performance is the end result.

### The 52nd Street Project Board of Directors

Ben Barenholtz  
Lisa Benavides  
Rachel Chanoff  
Cathy Dantchik  
Noël Dawkins  
Wendy Ettinger,  
*chair emeritus*  
Louis P. Friedman  
Stephen Graham, *chair*  
Larry Jones  
James McDaniel  
Frances McDormand  
Patricia M. Murphy, Esq.

Carol Ochs  
Willie Reale,  
*founder*  
Gus Rogerson  
Shirley Rumierk,  
*alumni member*  
José Soto, Jr.,  
*alumni member*  
Pamala Tyson  
Laura Valeroso  
Wendy vanden Heuvel  
John A. Vassilaros  
Jenny Wiener

### Special Thanks

We're extremely grateful to **Eric Karpeles** and **Mike Sell**, who graciously allowed us to use their beautiful home in Pennsylvania as our base of operations for the writer's retreat. Thanks also to our terrific host families, the **Cobbs**, the **Pursches**, the **Rutledges**, **Sohail Raikhy**, the **Stoekles**, the **Heyns**, **Katy Homans** and **Patterson Sims**, and the **Spoerris**. We must also express our gratitude to **Billy Carden**, **David Apichell**, **Matt**, and the rest of the staff of **HB Playwright's Foundation**.

### In-Kind Contributions

Thanks must be doled out to **Neil A. Mazzella** and **Hudson Scenic Studios**; the **Murphy Law Office**; **Iris A. Brown**; **Ron Kastner** and **Capital Printing**; **Big Apple Lights**; **Coleman**; **Noggin**; **The Printing Store**; **Scholastic, Inc.**; **Diageo Chateau & Estate Wines**; **Sesame Workshop**; **Watkins, Inc.**; **Mayor's Office of Film & Television**; **Boylan's Bottling Co.**; **David Sneddon & Fairway Market**; **Andy Millon**; **Steve Olsen & The Westbank Cafe**; **Lorraine Tobias & Imaginary Studios**; **Jive Records**, part of **Zomba Music Group**; and **Prime Films**.



## STOP THE PRESSES: THE SENSATIONAL PLAYS - ACT I

All original music composed by Joel Derfner

### Spending Christmas Together for the First Time

by Mande Santiago, age 12. Dramaturg/Director: Rick Meese

Ashley .....Toya Lillard  
Skye .....Caroline Clay

"We're Spending Christmas Together for the First Time" lyrics by Mande Santiago

### The Gymnasium Place

By Mordecai Santiago, age 9. Dramaturg/Director: Joe White

Jogo .....Felix Solis  
Ogoj .....Maria Tucci  
Kids .....Anthony Mejia and the crew  
Priest .....George Babiak

### Reggie and Carlos' Adventure

by Christopher Ramirez, age 11 (He will be 12 on Saturday).  
Dramaturg/Director: Jonas Oppenheim

Reggie .....Robert Colston  
Carlos .....Christopher Randolph  
Little Girl and Dad .....Crew

"My Family" and "We're Free" lyrics by Christopher Ramirez.

### At the Park

by Johnathan Rosario, age 9. Dramaturg/Director: Erica Schmidt

Licker .....Eris Migliorini  
Player .....Michael Stuhlbarg

### Two Everlasting

by Crystal Toro, age 10. Dramaturg/Director: Danny Johnson

Falisha .....Lizzy Davis  
Jennifer .....Cara Marcous  
Principal .....Danny Johnson

"We are Teachers Too For Life" lyrics by Crystal Toro

 **Intermission!** 

## STOP THE PRESSES: THE SENSATIONAL PLAYS - ACT II

### Differences

by Bryant Acosta, age 9. Dramaturg/Director: Sascha Paladino

Joey .....Nate Corddy  
Mike .....John Conlee  
Billy Evans .....Adam Robinson  
Jasmine Lopez .....Solangee Acosta

"We Both Wanted to Win" lyrics by Bryant Acosta.

### A Stupid Cheetah

by Merlaine Mendez, age 10.

Dramaturg: Robert Sean Leonard, Director: Lizzie Gottlieb

Spotty .....Armando Riesco  
Antlers .....Saidah Arrika Ekulona

### The Way You Meet a Friend on Manhattan Streets

by Kayelani Silva, age 11. Dramaturg/Director: Kia Corthron

Ashely .....Erin Quinn Purcell  
Lovebird Rodriguez .....Abigail Lopez  
Offstage voices .....Charlie Tocantins

### Betrayed

by Isayah Muller, age 10. Dramaturg/Director: John L. Sheehy

Tazz the Dancing Freak .....Victor Rojas  
Diesel Batista .....Reg Flowers  
The Cop .....Charlie Tocantins

### The Lovers and The Fighters

By Yaiana Vasquez Tineo, age 10. Dramaturg/Director: Mary Pat Walsh

Yesinl .....Lizbeth Mackay  
Mareo .....David Eigenberg  
The Doctor .....Ariana Casablanca

"I Still Love You" lyrics by Yaiana Vasquez Tineo

*Happy*  *Holidays!*

Barker Welfare Foundation, Blythmour Corporation, Capital Research Company, Carnegie Corporation of New York, Comedy Central, Davis Polk & Wardwell, Deutsche Bank of Americas Foundation, The Dramatists Guild Fund, Dramatists Play Service, Eleanor, Adam & Mel Dubin Foundation, Entertainment Weekly, The Fan Fox & Leslie R. Samuels Fdn., The J. Paul Getty Trust, Office of Assembly Member Richard Gottfried, The Horace W. Goldsmith Foundation, Holland Lodge Foundation, Inc., Betty E. & George B. Kaiser Foundation, Lemle Pictures, Inc., Lloyds TSB Bank plc, Lucille Lortel Foundation, Lucent Technologies, James A. Macdonald Foundation, Major League Baseball, Mellon Bank, N.A., The Cynthia & George Mitchell Foundation, The National Board of Review, Newman's Own, The New World Foundation, The New York Times Co. Foundation, Paramount Pictures, Pfizer Foundation, Philip Morris Companies, Roulette Entertainment, Rytech Inc., St. James' Church, Susquehanna Partners, G.P., Theatre Communications Group, Inc., John A. Vassilaros & Son, Inc., The Vervane Foundation, West Bank Café, Felix Zarembo & Co. Inc. (List current as of 10/31/02)

Jace Alexander & Maddie Corman  
 Cecilia Arana-Grant & Kevin Grant  
 Lucie Amaz & Laurence Luckinbill  
 Debbon Ayer  
 June Ballinger & Michael Goldstein  
 Arija Bareikis  
 Ben Barenholtz  
 Benny Bartley  
 Jessica Bauman  
 Laurie Becker & Rick Sweren  
 Gregory Bello  
 Lisa Benavides & Tim Nelson  
 Vicky Bijur & Ed Levine  
 Lewis Black  
 Richard Blackstone & Yldeez Yuksek  
 Tessa Blake  
 Buzz Bovshov  
 Julie Boyd  
 Bob Boyett  
 Becky Browder & Ted Neustadt  
 Susan Bruce & Peter Hedges  
 Michael Buchanan  
 Phoebe Cates & Kevin Kline  
 Alfred C. Cerullo III  
 Rachel Chanoff  
 Sharon Chantile  
 Glenda Chesshir  
 Kirk & Katherine Holt Citron  
 Darah Cloud & Dave Owens  
 Ethan Coen & Trish Cooke  
 Ruth Cohen  
 Lieta Hesen-Cohen & Richard Cohn  
 Elizabeth Cooper Davis  
 & Gordon J. Davis  
 David Copeland  
 Hyla & Richard Crane  
 Margaret Crimmins  
 Peter & Barbara Cross  
 Emily Crow  
 Catherine Curtin  
 Willem Dafoe & Liz Lecompte  
 Nadia Dajani  
 Arthur Dantchik  
 Cathy Dantchik  
 Peter & Judith Dawkins  
 Noël Dawkins & Joe Mihalow  
 Georgia & William Delano  
 Jonathan Demme  
 Stephen DeRosa  
 Cameron Diaz  
 Buddy Dikman & Chuck Davis  
 Alex Draper & Lorraine Tobias  
 Richard & Rebecca Dresser  
 Moira Driscoll & David Pence  
 Christopher & Karen Eddowes  
 Mario Egozi  
 David Eigenberg  
 Ned Eisenberg & Patricia Dunnock  
 Beth Emelson  
 Nora Ephron  
 Barbara Ettinger & Sven Huseby  
 Heidi Ettinger  
 Wendy Ettinger & Derek McLane

Tom Feeney & Paul Parzuchowski  
 Peter Jay Fernandez & Denise Burse  
 Martin Ross Felner  
 Angelina Fiordellisi & Matt Williams  
 Anita Flanagan & Jeff Potter  
 Alexa Fogel  
 Frank Frattaroli  
 Katherine Freedman  
 Naomi Freundlich & Charles Miles  
 Louis & Patrice Friedman  
 Michael & Sonya Gaffney  
 Janeanne Garofalo  
 Rose Gasner & Larry Chertoff  
 Jonathan Gazdak  
 Cora Cahan & Bernard Gersten  
 Jilian Cahan Gersten  
 Ileen Getz & Mark Grinnell  
 Paul & Elizabeth Giamatti  
 Toni Giamatti  
 Nancy Giles  
 Lloyd & Kitty Gilmour  
 Bryan Gmitter  
 Judy Goldman & Michael Pillingier  
 Tony Goldwyn & Jane Musky  
 Fred & Nancy Goodman  
 Lizzie Gottlieb  
 Stephen & Cathy Graham  
 Michael Greif & Jonathan Fried  
 Emily Grishman & Susan Sampliner  
 Lisa Gugenheim  
 Mark & Valerie Hadjipateras  
 Lynn E. Harris  
 Jane & Jonathan Heine  
 Peter Herdrich & Karen Trott  
 Colleen Hindsley  
 William Holtzman & S. Sylvia  
 Shepard  
 Katy Homans & Patterson Sims  
 Matthew Houston  
 Barbara Howard  
 Philip & Alexandra Howard  
 Kate Hudson & Chris Robinson  
 Dana Ivey  
 Mark Evan Jacobs  
 Whitney Scott & Peter Jacobson  
 Amanda Johns  
 Andrea Johnson  
 Traci Paige Johnson  
 & Robert Mowen  
 Larry & Mary Jones  
 Maurice Kanbar  
 Eric Karpeles & Mike Sell  
 Ronald Kastner & Vanessa Boeys  
 Stephen & Sharon Kepniss  
 Judy Kuhn & David Schwab  
 Roger & Belle Kuhn  
 Allan & Nanette Larson  
 Michael P. Lawrence  
 Kate Lear & Jonathan LaPook  
 Mary Ann Lefort  
 Warren Leight  
 Robert Sean Leonard  
 Liza Lerner

Aimee Levine  
 Joshua Lewis  
 Anna Li  
 Linda Li  
 Adrienne Lobel & Mark Linn Baker  
 John Lyons  
 Grace Lyu-Volkhausen  
 Barry Mackall  
 & Bill Schwinghammer  
 Marsue & Peter MacNicol  
 Greg MacPherson  
 & Jane Perlmutter  
 Roma Maffia  
 Rusty Magee & Alison Fraser  
 Cora Cahan & Bernard Gersten  
 Elizabeth Manne  
 Donald Margulies & Lynn Street  
 Richard Marin  
 Sonya Martin  
 John Matoian  
 Kay Matschullat & Allan Arffa  
 Brigid Mccarthy  
 Fran McDormand & Joel Coen  
 Jerry McGill  
 William Michael McMahon  
 & Meg McMahon  
 Rick Meese & Dan Lori  
 Richard & Denise Menelly  
 Josie Merck & Jim Stevenson  
 Audrey & Danny Meyer  
 Nancy Meyer & Marc Weiss  
 Emily & John Morgan  
 Alfred H. Morris  
 Bob Morris  
 Meg Mortimer  
 Suzen Murakoshi  
 Patricia M. Murphy, Esq.  
 & Adam Spilka  
 Geoffrey Nauftis  
 Eric Nedelander  
 Don & Sara Nelson  
 Pamela & Peter Nelson  
 Randy & Rona Nelson  
 Ruth Nelson  
 Mark Nesselson, M.D.  
 & Elliott Rosenblum  
 Lori O'Connor  
 Kevin O'Rourke & Edith Thurber  
 Carol Ochs & Bruce MacVittie  
 Jacki Ochs & Jan Kroezee  
 Lenore Pemberton  
 Elizabeth Peters  
 Peter & Ana Rosa Phillips  
 Oliver Platt & Camilla Campbell Platt  
 Jeremy Posner  
 Dean & Leslie Potashner  
 Michael Potts  
 Christopher Randolph  
 Peter & Helen Randolph  
 Richard Rauchenberger  
 Willie Reale & Jenny Gersten  
 Theresa Rebeck & Jess Lynn  
 Herald & Linda Ritch

David & Anita Rogerson  
 Robin Morse & Gus Rogerson  
 Arthur H. Rosenbloom  
 Daryl Roth  
 Alexander Roy  
 Shirley Rumiak  
 Mark Saad  
 Steve Sabba  
 Arnold & Agnes Sametz  
 Laura Sametz  
 Elizabeth Santeix  
 Zeborah Schachtel  
 Karin & Tom Schall  
 Leslie Schine & Nils Nilsen  
 Maury Schott  
 Ken & Mary Ann Schuster  
 Richard Schwartz  
 Dana Segal  
 Stefan Selig  
 Mitchell Semel & Colleen Carroll  
 Richard Shaffer & Nataalka Bukalo  
 Aaron & Elaine Shapiro  
 Bernice Baruch Shawl  
 Abby Jo Sigal & Matt Turner  
 Meg Simon  
 Landon Slane  
 Talia Balsam & John Slattery  
 Abigail Rose Solomon  
 Jean Stein  
 Ben & Christine Stiller  
 David & Sara Stone  
 Abby Stranahan & Dave Ward  
 Paola Styron  
 Susanna Styron & Darrell Larson  
 Brian Swardstrom  
 & Bonnie Bernstein  
 Daniel Swee  
 Mariko Tada  
 Crystal Thompson  
 Gina Torres  
 Anne Torsiglieri & Michael Bernard  
 Carl & Edna Torsiglieri  
 Liz Tuccillo  
 John & Katherine Turturro  
 Laura Valeroso & David Seidman  
 Josephine Eke & Jason Valk  
 Wendy vanden Heuvel & Brad Coley  
 Ed Vassallo  
 John A. Vassallo  
 John Vassilaros & Alexandra Gersten  
 Susan Vitucci  
 Mary Pat Walsh  
 Borah & Mildred Walton  
 Maja Wampuszyc  
 Wendy Wasserstein  
 Anita Waxman  
 Ann & Paul Weiss  
 Sally & Lenny Weiss  
 Jane Bolster & Steve Wertimer  
 Carol Whitesides  
 Jenny Wiener & Jon Steingart  
 Michael & Zena Wiener  
 Donald Windham

*The 52nd Street Project Presents*



# ALL ABOOOOARD!

## THE DEPARTURE PLAYS

### THE 2003 TWO-ON-TWOS

FRIDAY, JANUARY 31 AT 7:30 P.M.

SATURDAY, FEBRUARY 1 AT 3:00 & 7:30 P.M.

SUNDAY, FEBRUARY 2 AT 3:00 P.M.

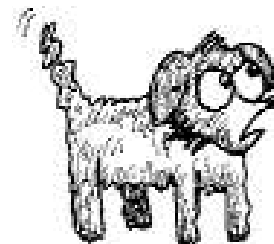

## THE WOMEN'S INTERART ANNEX

500 W. 52ND ST., #2A

THE 2003 TWO-ON-TWOS  
**ALL ABOOOOARD! THE DEPARTURE PLAYS**  
 THE WOMEN'S INTERART ANNEX - JAN. 31-FEB. 2, 2003

**The 52nd Street Project Staff:**

Gus Rogerson, Artistic Director  
 Carol Ochs, Executive Director  
 John Sheehy, Director of Development and Marketing  
 Megan Sandberg-Zakian, Associate Artistic Director  
 George "X-Acto" Babiak, Production Manager  
 Liz Bell, Director of Education  
 Diana Rojas, Executive Assistant  
 Chris Ceraso, Teen Dean  
 Iris A. Brown, Graphic Designer  
 Mayleen Cancel and Jaymaree Rosado, Receptionists  
 Interns: Alex Kranz and Jolie Tong

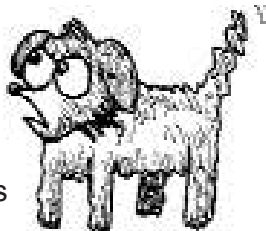

**Composer/Musical Director:**

Patrick Barnes

**Set Designer:**

Kevin Joseph Roach

**Lighting Designer:**

Greg MacPherson

**Costume Designer:**

Moe Schell

**Sound Designer:** Jeremy Posner

**Choreographer:** John Caraffa

**Stage Manager:**

Karen "K1" Parlato

**Slide Designers:**

Katherine Lumb, Richard Hicks,  
 Monty Nicol, Lee Rosen,  
 Kim Snow, Iwona Waluk,  
 and George Babiak

**"All Aboooard" Illustration:**

Leigh Pennebaker

**Prop Design Team:**

George Babiak, Chris Bonanos,  
 Rudi Katzke, Ani Kehr, Katherine  
 Lumb, Cara Marcous, Karen "K2"  
 Munkel, Samantha Padilla, Lee  
 Rosen, Jolie Tong

**Furniture Crew:**

George Babiak

**Prop Crew:** Katherine Acosta,

Alex Kranz, Johanna Vidal

**Load-in and Light Hang Crew:**

Alex Kranz, Karen "K2" Munkel,  
 Karen "K1" Parlato, Doug Nervik,  
 Nicole Watson

**House Manager:** Liz Bell,

Karin Schall, Mary Pat Walsh,

**Host and Guest Chef:** Maria Tucci

**Master Chefs:**

Carol Ochs & John Sheehy



NATIONAL  
 ENDOWMENT  
 FOR THE ARTS

The Two-on-Two Program is made possible with public funds from the National Endowment for the Arts; The New York State Council on the Arts, a state agency; and the New York City Department of Cultural Affairs. The 52nd Street Project is a member of Art/NY.

State of the Arts



NYS CA

**COOL STUFF ON SALE!**

Flyer Bars .....\$2.00, \$1.50 & \$1.00

*Shel Silverstein's "Fivey and Twoey" logo gear:*

Project Sweatshirts .....\$20.00

Project Long Sleeve T-Shirts .....\$15.00

Project Caps .....\$15.00

Project Mugs .....\$5.00

Project Pencil 3-pack .....\$1.00

"Sweet Appreciation" CD .....\$25.00

Thank you for coming to **ALL ABOOOOARD!** If you are not on our mailing list (or if your address has changed), please fill out this form and give it to us on your way out or mail it to the address below. We would also like to know if you are interested in becoming a volunteer. We need help in **all areas**, so be sure to fill out the entire form.

**PLEASE ADD ME TO YOUR MAILING LIST:**

1/03

NAME: \_\_\_\_\_

ADDRESS: \_\_\_\_\_

ZIP \_\_\_\_\_

HOME PHONE: \_\_\_\_\_

DAYTIME PHONE: \_\_\_\_\_

E-MAIL ADDRESS: \_\_\_\_\_

MY OCCUPATION: \_\_\_\_\_

MY HOBBIES: \_\_\_\_\_

**YES, I WOULD LIKE TO BE OF HELP. I CAN:**

- |   |   |  |
|---|---|--|
| <input type="checkbox"/> Help load in and out for shows | <input type="checkbox"/> Draw and/or paint  | <input type="checkbox"/> Help kids with homework |
| <input type="checkbox"/> Hang lights                    | <input type="checkbox"/> Help with mailings | <input type="checkbox"/> Teach kids a skill      |
| <input type="checkbox"/> Work on a backstage crew       | <input type="checkbox"/> Do office work     | <input type="checkbox"/> Be a chef at an event   |
| <input type="checkbox"/> Do graphic design              | <input type="checkbox"/> Design sound       | <input type="checkbox"/> Design and sew costumes |
| <input type="checkbox"/> Other (please specify) _____   |   |  |

**MY SCHEDULE IS:**

- Very flexible. I'm often available during weekdays.  
 Somewhat flexible. I can help on the occasional morning or afternoon during the week.  
 Not very flexible at all, but I've got some free time on evenings and weekends.

If you would like to mail this (and you're always welcome to enclose a tax-deductible contribution), you can send it to: **The 52nd Street Project**, 500 West 52nd St., New York, NY 10019. Or fax it to (212) 333-5598.

## Don't Miss Our Upcoming Shows!

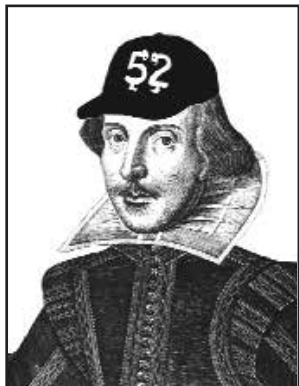

### The 2003 Teen Ensemble Sonnet Scenes

Co-written by William Shakespeare  
and the teens of the 52nd Street Project

Saturday, March 1 at 7:30 p.m. and  
Sunday, March 2 at 3:00 p.m. right here at

The Women's Interart Annex

Call (212) 642-5052 for reservations.

## KNOCK WOOD!

### THE SUPERSTITIOUS PLAYS

MARCH 28-30 AT THE  
BECKETT THEATER IN THE NEW  
THEATRE ROW COMPLEX ON 42ND ST.

THE SPRING  
PLAYMAKING  
SERIES



## HEART SOCIETY

THE 52nd Street Project

BANK JOB BENEFIT

Monday,  
May 12 at

## CAPITALE

For more  
information or  
reservations call

John

"Mr. Big"

Sheehy

at 212/333-5252.

The 52nd Street Project is a non-profit organization that brings children from the Hell's Kitchen neighborhood together with professional theater artists to create original theater. **All Aboooooard** is a production of our Two-on-Two program, in which an adult playwright crafts a piece for a pair of Project kids to perform. Another adult directs the kids for a month that includes an intensive three-day weekend in Dutchess County, New York. Tonight's performance is the final result.

### The 52nd Street Project Board of Directors

Ben Barenholtz

Lisa Benavides

Rachel Chanoff

Cathy Dantchik

Noël Dawkins

Wendy Ettinger,

*chair emeritus*

Louis P. Friedman

Stephen Graham, *chair*

Larry Jones

James McDaniel

Frances McDormand

Patricia M. Murphy, Esq.

Carol Ochs

Willie Reale,

*founder*

Gus Rogerson

Shirley Rumierk,

*alumni member*

José Soto, Jr.,

*alumni member*

Pamala Tyson

Laura Valeroso

Wendy vanden Heuvel

John A. Vassilaros

Jenny Wiener

### Special Thanks

We're grateful to **Margot, Ronnie, Paul**, and the rest of the staff at **Women's Interart Annex** for making their extremely convenient space available to us. We also owe big-time thanks to **Maria Tucci** and **Robert Gottlieb, Lili Taylor and Gerard**, and **Derek McLane** and **Wendy Ettinger**, all of whom graciously allowed us to use their upstate homes for three tumultuous and fun-filled days. Our gratitude also goes to Super Project Pal **Ron Fiorina** of **Boylan Bottling Co.**, **Mary Moore** and **D'Agostino's Supermarkets**, and board member **John A. Vassilaros** (a.k.a. Johnny Coffeeshopolis) for contributing our intermission refreshments. We are also grateful for the extraordinary amount of snow this year.

# ALL ABOOOOARD! – ACT ONE

All original music composed by Patrick Barnes,  
except where noted

## Raining Cats and Dogs

By Jonathan Bernstein. Directed by Lee Rosen

Pigeonhole ..... Kimani Lewis-Ashley  
Fillibuster ..... Anthony Mejia  
Voice of Smidge ..... Lee Rosen

“Scared” and “Just Jump” lyrics by Jonathan Bernstein

## Samson and Calliope

by Zabryna Guevara. Directed by Glynis Rigby.

Samson Daleworth ..... Wonkezeh Newenle  
Calliope ..... Samantha Padilla



“Amuse a Muse” lyrics by John Sheehy

## Amor Es Un Tren

By R.N Sandberg. Directed by Megan Sandberg-Zakian.

Anita/Andrea ..... Ivana Granados  
Rosalia/Rufina ..... Ariana Casablanca  
Carlos/Announcer ..... Gus Rogerson

“Amor Es Un Tren” lyrics by R.N. Sandberg.

 **Intermission!**   
Root Beer Floats, Coffee,  
and Flyer Bars in the lobby!

# ALL ABOOOOARD! – ACT TWO

## A Little Less Conversation

By Anne Torsiglieri. Directed by Kim Sykes.

Ralph ..... Mike Grullon  
Loretta ..... Solangee Acosta  
Announcer ..... Gus Rogerson  
Foreign competitors ..... George Babiak and Alex Kranz

“What Would Elvis Do?” music and lyrics by Josh Lewis.

## Discovering America

by Cynthia Kaplan. Directed by Becky White.

Cassie ..... Anastasia Kehr  
Shelly ..... Suzette Santana

“Shelly’s Lament” and “It’s Lonely Being a Genius” lyrics by  
Cynthia Kaplan.

## All We Gotta Do

By Michael Bernard. Directed by Joe Mihalow.

Jonathan ..... Jonathan Hagemeyer  
Stephen ..... Stephen Galimidi

“Less” lyrics by Michael Bernard.

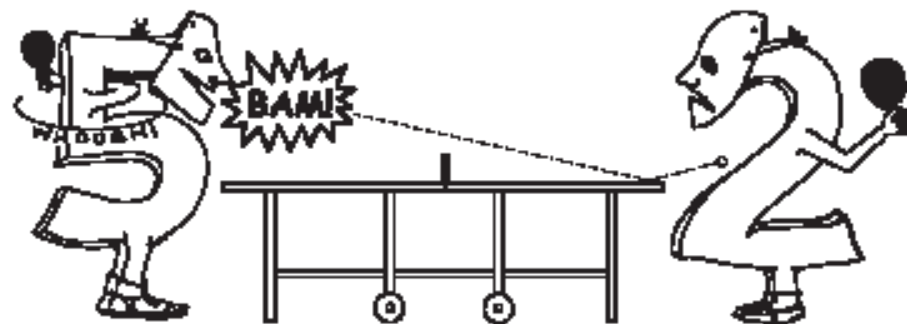

The 52nd Street Project gratefully acknowledges the following foundations and corporations: Barker Welfare Foundation, The Barnsley Foundation, Bloomberg L.P., California Comedy, Capital Research Company, Carnegie Corporation of New York, Comedy Central, Davis Polk & Wardwell, Deutsche Bank of Americas Foundation, The Dramatists Guild Fund, Dramatists Play Service, Eleanor, Adam & Mel Dubin Foundation, Entertainment Weekly, The Fan Fox & Leslie R. Samuels Foundation, The Horace W. Goldsmith Foundation, The William and Mary Greve Foundation, The Hennessy Foundation, Holland Lodge Foundation, Inc., Lloyds TSB Bank plc, Lucille Lortel Foundation, James A. Macdonald Foundation, Major League Baseball, Mellon Bank, N.A., The New World Foundation, The New York Times Company Foundation, Newman's Own, Philip Morris Companies, Rytech Inc., St. James' Church, Stranahan Foundation, Susquehanna Partners, G.P., John A. Vassilaros & Son, Inc, The Vervane Foundation, Felix Zarembo & Co. Inc. In addition the following individuals made gifts of over \$200 this year (list is current as of 3/27/03)

Jace Alexander & Maddie Corman  
Lucie Arnaz and Laurence  
Luckinbill  
Dylan & Becky Baker  
Ben Barenholtz  
Jessica Bauman  
Laurie Becker & Rick Sweren  
Lisa Benavides & Tim Nelson  
Vicky Bijur & Ed Levine  
Lewis Black  
Richard Blackstone & Yldeez  
Yuksek  
Tessa Blake  
Buzz Bovshow  
Bob Boyett  
Becky Browder & Ted Neustadt  
Susan Bruce & Peter Hedges  
Alfred C. Cerullo III  
Rachel Chanoff  
Glenda Chesshir  
Kirk & Katherine Holt Citron  
Darah Cloud & Dave Owens  
Ruth Cohen  
Lieta Hesen-Cohen & Richard  
Cohn  
Tricia Cooke & Ethan Coen  
Hyla & Richard Crane  
Margaret Crimmins  
Billy Crudup  
& Mary Louise Parker  
Catherine Curtin  
Willem Dafoe & Liz Lecompte  
Arthur Dantchik  
Cathy Dantchik  
Leslie Dantchik  
Peter and Judith Dawkins  
Georgia and William Delano  
Jonathan Demme  
Richard and Rebecca Dresser  
Christopher and Karen Eddowes  
Mario Egozi  
David Eigenberg  
Ned Eisenberg & Patricia Dunnock  
Nora Ephron

Wendy Ettinger and Derek McLane  
Tom Feeney & Paul Parzuchowski  
Peter Jay Fernandez & Denise  
Burse  
Martin Ross Fetner  
Angelina Fiordellisi  
Alexa Fogel  
Frank Frattaroli  
Katherine Freedman  
Naomi Freundlich & Charles Miles  
Louis and Patrice Friedman  
Janeanne Garofalo  
Rose Gasner & Larry Chertoff  
Ileen Getz & Mark Grinnell  
Paul & Liz Giamatti  
Lloyd and Kilty Gilmour  
Judy Goldman & Michael Pillingier  
Tony Goldwyn & Jane Musky  
Stephen and Cathy Graham  
Michael Greif & Jonathan Fried  
Lisa Gugenheim  
Mark and Valerie Hadjipateras  
Jane and Jonathan Heine  
Peter Herdrich and Karen Trott  
William Holtzman & S. Sylvia  
Shepard  
Katy Homans & Patterson Sims  
Barbara Howard  
Phillip & Alexandra Howard  
Dana Ivey  
Mark Evan Jacobs  
Sy Jacobs  
Whitney Scott & Peter Jacobson  
Andrea Johnson  
Traci Paige Johnson and Robert  
Mowen  
Larry & Mary Jones  
Maurice Kanbar  
Ronald Kastner & Vanessa Boeys  
Seth and Beth Klarman  
Judy Kuhn & David Schwab  
Allan and Nanette Larson  
Michael P. Lawrence  
Mary Ann Lefort

Joshua Lewis  
Anna Li  
Linda Li  
Adrienne Lobel and Mark Linn  
Baker  
John Lyons  
Grace Lyu-Volckhausen  
Greg MacPherson & Jane  
Perlmutter  
Nat Magee & Alison Fraser  
Wendy Makkena  
& Bob Krakoway  
Kay Matschullat & Allan Arffa  
Paul McCrane and Dana Kellin  
Frances McDormand & Joel Coen  
William Michael McMahon & Meg  
Mcmahon  
Rick Meese & Dan Lori  
Richard & Denise Menelly  
Josie Merck & Jim Stevenson  
Brian Mertes  
Audrey and Danny Meyer  
Suzen Murakoshi  
Patricia M. Murphy, Esq. & Adam  
Spilka  
Don & Sara Nelson  
Ruth Nelson  
Mark Nesselson, M.D. & Elliott  
Rosenblum  
Lori O'Connor  
Kevin O'Rourke  
& Edith Thurber  
Carol Ochs & Bruce MacVittie  
Jacki Ochs & Jan Kroeze  
Elizabeth Peters  
Peter and Ana Rosa Phillips  
Oliver Platt and Camilla Campbell  
Platt  
Jeremy Posner  
Dean and Leslie Potashner  
Peter and Helen Randolph  
Richard Rauchenberger  
Willie Reale & Jenny Gersten  
Theresa Rebeck & Jess Lynn

Herald & Linda Ritch  
David & Anita Rogerson  
Robin Morse & Gus Rogerson  
Mark Saad  
Steve Sabba  
Laura Sametz  
Karin and Tom Schall  
Leslie Schine & Nils Nilsen  
Maury Schott  
Ken & Mary Ann Schuster  
Mitchell Semel & Colleen Carroll  
Tom Shadyac  
Richard Shaffer & Nataalka Bukalo  
Aaron & Elaine Shapiro  
Bernice Baruch Shawl  
Abby Jo Sigal & Matt Turner  
Meg Simon  
Talia Balsam & John Slattery  
Abigail Rose Solomon  
Jean Stein  
David and Sara Stone  
Abby Stranahan & Dave Ward  
Susanna Styron & Darrell Larson  
Brian Swardstrom & Bonnie  
Bernstein  
Daniel Swee  
Mariko Tada  
Laura Valeroso & David Seidman  
Wendy vanden Heuvel  
& Brad Coley  
Ed Vassallo  
John A. Vassallo  
Mary Pat Walsh  
Wendy Wasserstein  
Sally & Lenny Weiss  
Jane Bolster and Steve Wertimer  
Carol Whitesides  
Michael and Zena Wiener  
Donald Windham  
Joanne Woodward & Paul  
Newman  
Bill Wrubel & Jennifer Crittenden  
Jeffrey and Janine Yass  
James & Mary Lin Yoshimura

THE 52ND STREET PROJECT PRESENTS



### And from the good folks at Theatre Row...

In the event of Fire, please proceed quietly to the nearest exit. Exits are located where you entered the Theater Complex and at the back of the Stage, which you can reach by walking through any opening in the scenery or drapes on stage.

This Theater is operated by Theatre Row Studios and 42nd Street Development Corporation as a service to individuals and companies who do not have their own performance spaces. This presentation is not a Theatre Row Studios or 42nd Street Development Corporation production, nor does its presentation in this Theater imply approval or sanction by either Theatre Row Studios or 42nd Street Development Corporation.

For information on rental of this Theater, please contact Peter Bloch, General Manager - Theatre Row Studios at (212) 714 - 2442.

The use of cameras and other recording devices in this Theater is prohibited by law.

There is no smoking anywhere in this Theater or in the Theater Complex, including, lobby, stairways and restrooms.

## The Superstitious Plays

THE WINTER 2003 PLAYMAKING SERIES  
**THE SAMUEL BECKETT THEATER**  
IN THE NEW THEATRE ROW, 410 W. 42ND ST.

FRI., MAR. 28 AT 7:30 P.M.,  
SAT., MAR. 29 AT 3:00 AND 7:30 P.M.,  
AND SUN., MAR. 30 AT 3:00 P.M.

**THE WINTER 2003 PLAYMAKING SERIES  
KNOCK WOOD: THE SUPERSTITIOUS PLAYS  
THE SAMUEL BECKETT THEATER - MAR. 28-30**

**The 52nd Street Project Staff:**

Gus Rogerson, Artistic Director  
 Carol Ochs, Executive Director  
 John Sheehy, Director of Development and Marketing  
 Megan Sandberg-Zakian, Associate Artistic Director  
 George "X-Acto" Babiak, Production Manager  
 Liz Bell, Director of Education  
 Diana Rojas, Executive Assistant  
 Chris Ceraso, Teen Dean  
 Iris A. Brown, Graphic Designer  
 Mayleen Cancel and Jaymaree Rosado, Receptionists  
 Interns: Josh Buchman, Alex Kranz, Aaron Sandfield



**Composer/Musical Director:**

Loren Toolajian

**Set Designer:**

Kevin Joseph Roach

**Lighting Designer:**

Greg MacPherson

**Costume Designer:**

Crystal Thompson

**Costume Assistant:**

Jennifer Jimenez

**Goddess of Sound:**

Vanessa Valdes

**Stage Manager:**

Katherine Lumb

**Slide Designers:**

Katherine Lumb, Richard Hicks,  
 Monty Nicol, Lee Rosen,  
 Kim Snow, Iwona Waluk,  
 and George Babiak

**"Knock Wood" Illustration:**

Heather Carnduff

**Prop Design Team:**

George Babiak, Paul Boyd, Josh  
 Buchman, Heather Carnduff, Hakim  
 Latimore, Jeff LeGreca,  
 Cara Marcous, Karen Munkel,  
 Abigail Ransmeier, Aaron Sandfield,  
 John Sheehy

**Furniture Crew:**

Erik Bowie, Alex Kranz, Alex Tomas

**Prop Crew:** Aaron Sandfield,

Josh Buchman, Ariana Casablanca

**Load-in and Light Hang Crew:**

Kelly Blackwell, Alex Kranz,  
 Karen Munkel, Doug Nervik,  
 Christopher Randolph, Chris Ryan,  
 Aaron Sandfield, Jolie Tong,  
 Jason Wells

**House Managers:** Liz Bell,

Karin Schall, Mary Pat Walsh

**Weekend Hosts:**

Stephen and Cathy Graham



NATIONAL  
 ENDOWMENT  
 FOR THE ARTS

The Playmaking Program is made possible with public funds from the National Endowment for the Arts; The New York State Council on the Arts, a state agency; and the New York City Department of Cultural Affairs. The 52nd Street Project is a member of Art/NY.

State of the Arts



**COOL STUFF ON SALE!**

Flyer Bars .....\$2.00, \$1.50 & \$1.00

*Shel Silverstein's "Fivey and Twoey" logo gear:*

Project T-Shirts .....\$12.00  
 Project Caps .....\$15.00  
 Project Mugs .....\$5.00  
 Project Pencil 3-pack .....\$1.00  
 "Sweet Appreciation" CD .....\$25.00

Thank you for coming to **KNOCK WOOD!** If you are not on our mailing list (or if your address has changed), please fill out this form and give it to us on your way out or mail it to the address below. We would also like to know if you are interested in becoming a volunteer. We need help in **all areas**, so be sure to fill out the entire form.

**PLEASE ADD ME TO YOUR MAILING LIST:**

3/03

NAME: \_\_\_\_\_

ADDRESS: \_\_\_\_\_

ZIP \_\_\_\_\_

HOME PHONE: \_\_\_\_\_

DAYTIME PHONE: \_\_\_\_\_

E-MAIL ADDRESS: \_\_\_\_\_

MY OCCUPATION: \_\_\_\_\_

MY HOBBIES: \_\_\_\_\_

**YES, I WOULD LIKE TO BE OF HELP. I CAN:**

- |   |   |  |
|---|---|--|
| <input type="checkbox"/> Help load in and out for shows | <input type="checkbox"/> Draw and/or paint  | <input type="checkbox"/> Help kids with homework |
| <input type="checkbox"/> Hang lights                    | <input type="checkbox"/> Help with mailings | <input type="checkbox"/> Teach kids a skill      |
| <input type="checkbox"/> Work on a backstage crew       | <input type="checkbox"/> Do office work     | <input type="checkbox"/> Be a chef at an event   |
| <input type="checkbox"/> Do graphic design              | <input type="checkbox"/> Design sound       | <input type="checkbox"/> Design and sew costumes |
| <input type="checkbox"/> Other (please specify) _____   |   |  |

**MY SCHEDULE IS:**

- Very flexible. I'm often available during weekdays.  
 Somewhat flexible. I can help on the occasional morning or afternoon during the week.  
 Not very flexible at all, but I've got some free time on evenings and weekends.

If you would like to mail this (and you're always welcome to enclose a tax-deductible contribution), you can send it to: **The 52nd Street Project**, 500 West 52nd St., New York, NY 10019. Or fax it to (212) 333-5598.

## Don't Miss Our Upcoming Shows!

# Heart SOCIETY

THE 52nd Street Project

BANK JOB BENEFIT

Monday, May 12 at "Capitale"

For more information or reservations call  
John "Mr. Big" Sheehy at 212/333-5252

WILLIAM SHAKESPEARE'S

# as you live it



ADAPTED BY CHRIS CERASO AND  
THE TEENS OF THE 52ND STREET PROJECT

DIRECTED BY MICHAEL BERNARD

## WORLD TOUR!

JUNE 27 - NEW YORK CITY - LOCATION T.B.A.  
JUNE 30 - LONDON - HARROW SCHOOL  
JULY 4 - LORGUES, FRANCE- CHATEAU DE BERNE

The 52nd Street Project is a non-profit organization that brings children from the Hell's Kitchen neighborhood together with professional theater artists to create original theater. **KNOCK WOOD** is a production of our Playmaking program. Young people participate in a nine-week playwriting course taught by **Megan Sandberg-Zakian** and adapted for the Project by **Daniel Judah Sklar** from his book *Playmaking: Children Writing and Performing Their Own Plays*. At the end of the course, each child is given two actors, a theme, and a dramaturg/director who guides him or her through the writing of a play during a weekend retreat in the country (Kent, Connecticut, for this show). Tonight's performance is the end result.

### The 52nd Street Project Board of Directors

Ben Barenholtz

Lisa Benavides

Rachel Chanoff

Cathy Dantchik

Noël Dawkins

Wendy Ettinger,

*chair emeritus*

Louis P. Friedman

Stephen Graham, *chair*

Larry Jones

James McDaniel

Frances McDormand

Patricia M. Murphy, Esq.

Carol Ochs

Willie Reale,

*founder*

Gus Rogerson

Shirley Rumierk,

*alumni member*

José Soto, Jr.,

*alumni member*

Pamala Tyson

Laura Valeroso

Wendy vanden Heuvel

John A. Vassilaros

Jenny Wiener

### Special Thanks

We're grateful to **Stephen and Cathy Graham** for graciously allowing us to bring the chaos of a Playmaking weekend to their lovely home in Kent, Connecticut. Their staff, including **Jeannie** and **Chef Eric**, get a round of applause, too. Thanks also go to **Sam and Lynn Waterston**, and **Oliver and Camilla Platt** for providing overnight accommodations.

Thanks also to **Charlie Tocantins**, **Blair Slinger** and **Madeleine George** for helping out in Playmaking class.



## KNOCK WOOD: THE SUPERSTITIOUS PLAYS – ACT I

All original music composed by Loren Toolajian

### **The 92 That Changed Everything**

by Nicole Fargardo, age 12. Dramaturg/Director: Maury Schott

Jesse .....Phyllis Somerville  
Joshua .....Alex Draper

*"The Dessert Song"* lyrics by Nicole Fargardo

### **Coney Island Wedding Deal**

By Steven Castellanos, age 9. Dramaturg: Kurt Wootton

Director: John Steber

Alligator .....Kenajuan Bentley  
Turtle of Life .....Sonia Manzano  
Rope handlers .....Alex Tomas, Ariana Casablanca

### **The Audition**

by Aladino Olivares, age 12. Dramaturg/Director: Greg Allen

Anthony .....Joel de la Fuente  
Ms. Jackson/Mom .....Malinda Walford  
Kid #1 .....Alex Tomas  
Kid #2 .....Ariana Casablanca

### **Raven's Bad Luck**

by Christine Tomas, age 10. Dramaturg/Director: Sandra McClain

Raven .....Mandy Gonzalez  
Madam Venus .....Shirley Rumierk  
Raven's Client .....Alex Kranz  
Cauldron bearer .....Alex Tomas  
Cop .....Ariana Casablanca

### **Reunited**

by Amanda Santos, age 12. Dramaturg/Director: Denise Burse

Alfedi .....Jose Soto  
Glaefideat .....Angel Desai

*"Apple Green Lullaby," "What Have I Done," and "I Feel So Bad"* lyrics

by Amanda Santos



## KNOCK WOOD: THE SUPERSTITIOUS PLAYS – ACT II

### **The Man That Rules Us All**

by Isaac Goodman-Boyd, age 10. Dramaturg/Director: George Babiak

George W. Bush .....Kevin O'Rourke  
Taylor .....Josh Lewis  
Secret Service agents .....Josh Buchman, Aaron Sandfield  
*"No Violence," "Alone," and "Bush's Feeling of War"* lyrics by Isaac  
Goodman-Boyd.

### **The Wish**

by Erica Arce, age 9. Dramaturg/Director: Nicole Watson

Eve .....Sarah Kay  
Spot .....Perry McBain-Daniel

### **The Clown Destroyer**

by Harlo Ulloa, age 9. Dramaturg/Director: Louise Andrews

Killer Kid .....Frank Wood  
Police Hero .....David Chandler  
Partygoers .....The Crew

### **Alone**

by Skye Blu Welsh, age 12. Dramaturg/Director: Sheryl Kaller

Nevaeh .....Elise Hernandez  
Heaven .....Julia Gibson

### **Fighting in the Sewers**

By Jose Martinez, age 10. Dramaturg/Director: Larry Nathanson

Spike Shell Iguana .....Ben Shenkman  
Crabhead Chicken .....Catherine Mueller  
*"Getting Red Hot" and "Let's Just Be Friends"* lyrics by Jose Martinez

### *IN MEMORIAM*

*These shows are being performed in memory of our beloved friend and volunteer, **Rusty Magee** (1955-2003), who composed over 100 songs for the Project. Some of these songs are being played in the house before the first act and during the intermission.*

*The performers on the recording are **David Costabile, Nancy Giles, Judy Kuhn, Michael Potts, Myra Lucretia Taylor, Mary Testa, Anne Torsiglieri, Karen Trott, and Lee Wilkof.** The production was done by Loren Toolajian at Broadway Sound. Many thanks to Alison Fraser and Sheryl Kaller.*

The **52nd Street Project Teen Ensemble** is a two-year program for graduates of The Project's writing and acting programs. The Teen Ensemble focuses on professional level acting technique by using both original and existing texts. The culmination of the program is the production of a play by William Shakespeare as adapted by the ensemble. The most recent teen production, **The Tempest**, was performed in the United Kingdom in the summer of 2001 at **Teatro Technis** in London and in Debenham, Suffolk. The teens you see tonight will journey to England and France this summer to present their own version of a Shakespeare play. The title remains top-secret.

### The Project Staff

Gus Rogerson . . . . .Artistic Director  
 Carol Ochs . . . . .Executive Director  
 John Sheehy . . . . .Director of Development  
 Megan Sandberg-Zakian . . . . .Associate Artistic Director  
 George Roman Babiak . . . . .Production Manager  
 Liz Bell . . . . .Director of Education  
 Chris Ceraso . . . . .Teen Dean  
 Iris A. Brown . . . . .Graphic Designer  
 Mayleen Cancel, Jaymaree Rosado . . . . .Receptionists  
 Alex Kranz . . . . .Intern

### The 52nd Street Project Board of Directors

Ben Barenholtz	Carol Ochs
Lisa Benavides	Willie Reale, <i>founder</i>
Rachel Chanoff	Gus Rogerson
Cathy Dantchik	Shirley Rumierk, <i>alumni member</i>
Noël Dawkins	José Soto, Jr., <i>alumni member</i>
Wendy Ettinger, <i>chair emeritus</i>	Pamala Tyson
Louis P. Friedman	Laura Valeroso
Stephen Graham, <i>chair</i>	Wendy vanden Heuvel
Larry Jones	John A. Vassilaros
James McDaniel	Jenny Wiener
Frances McDormand	
Patricia M. Murphy, Esq.	

The Project would like to thank **Margot Lewitin, Ronnie Geist, Paul Smithyman**, and **Women's Interart** for generously allowing us to use their space.

## The 52nd Street Project Presents



# 2003 Sonnet Scenes

*Co-written by William Shakespeare  
 and the Teens of the 52nd Street Project*

*Saturday, March 1st at 7:30 p.m.  
 Sunday, March 2nd at 3:00 p.m.*

*The Women's Interart Annex  
 500 W. 52nd St.*

# 2003 Teen Sonnet Scenes

## Go Fish

By Noel Polanco from Sonnet #64

Dramaturg/Director: Kate Marks

José .....Noel Polanco  
Addia .....Jaya Rosado

## Subservientus Ignoramus

By Anju Andre-Bergmann from Sonnet #57

Dramaturg/Director: Catherine Mueller

Minnie Mae Fredda Hedda Dubois .....Anju Andre-Bergmann  
Louisa Dubois .....Aisha Lena Jabour

## Creative Will

By Matthew Jellison from Sonnet #35

Dramaturg/Director: Michael Bernard

William Sopheman .....Matthew Jellison  
Richard Arson III .....Osage Lewis-Ashley

## One-Way Trip

By Jaya Rosado from Sonnet #44

Dramaturg/Director: Diana Rojas

Christy .....Jaya Rosado  
Lesley .....Anju Andre-Bergmann

## High Skoo Chronicle

By Osage Lewis-Ashley from Sonnet #34

Dramaturg/Director: Nancy Giles

Malik .....Osage Lewis-Ashley  
Vanessa .....Mayleen Cancél

## Chris and Lisa: The Loved Ones

By Johnathan Roldan from Sonnet #130

Dramaturg/Director: George Babiak

Chris .....Johnathan Roldan  
Lisa .....Natalie Musteata  
The Waiter .....Matthew Jellison

## One Girl Waiting

By Aisha Lena Jabour from Sonnet #109

Dramaturg: Chris Ceraso, Director: Jeanne Simpson

20 .....Aisha Lena Jabour  
10 .....Jennifer Jimenez

## White and Black

By Natalie Musteata from Sonnet #147

Dramaturg/Director: Josh Lewis

Alba .....Natalie Musteata  
Pierce .....Noel Polanco

## Thy Love

By Mayleen Cancel from Sonnet #91

Dramaturg/Director: Ceci Arana

Krissy .....Mayleen Cancél  
Krishna .....Matthew Jellison

## Jumping Giraffes In Monkey Soup or Peeps

By Jennifer Jimenez from Sonnet #23

Dramaturg/Director: Megan Sandberg-Zakian

Stokely .....Jennifer Jimenez  
William .....Noel Polanco

Stage Manager and Light Operator: Erik Bowie  
Sound Operator: Alex Kranz

**Intermission!**

Corporate Hosts

Ars Nova PGM

Louis Friedman, Bear Stearns

Tobak-Dantchik Events

and the Board of Directors of The 52nd Street Project present

# HEIST SOCIETY



**MONDAY, MAY 12, 2003 AT CAPITALE**

**BOARD CHAIR**

Stephen Graham

**ARTISTIC DIRECTOR**

Gus Rogerson

**EXECUTIVE DIRECTOR**

Carol Ochs

## CO-CHAIRS

Lisa Benavides  
Becky Browder  
Cathy Dantchik  
Louis P. Friedman

Patrice Friedman  
Karin Schall  
Laura Valeroso  
Mary Pat Walsh

Jenny Wiener

## THE BOARD OF DIRECTORS

Ben Barenholtz  
Lisa Benavides  
Rachel Chanoff  
Cathy Dantchik  
Noël Dawkins  
Wendy Ettinger, *chair emeritus*  
Louis P. Friedman  
Stephen Graham, *chair*  
Larry Jones  
James McDaniel  
Frances McDormand

Patricia M. Murphy, Esq.  
Carol Ochs  
Willie Reale, *founder*  
Gus Rogerson  
Shirley Rumierk, *alumni member*  
José Soto, Jr., *alumni member*  
Pamala Tyson  
Laura Valeroso  
Wendy vanden Heuvel  
John A. Vassilaros  
Jenny Wiener

## THE 52ND STREET PROJECT GRATEFULLY ACKNOWLEDGES...

Stephanie Berger  
Iris A. Brown  
Bourjois  
Capital Printing/Ronald J. Kastner  
Kenneth Cole Productions  
Diageo Chateau & Estate Wines Co.  
Entertainment Weekly  
Alison Fraser  
Neil Mazzella and Hudson Scenic Studios  
Jive Records/A division of Zomba Music Group  
Newman's Own  
Noggin  
The Printing Store  
Scholastic, Inc.  
Sesame Workshop  
Wendy Stulberg  
Tarte, Inc.  
Terax America  
John A. Vassilaros & Sons  
Watkins Incorporated  
*Healthier Living Since 1868*



## HEIST SOCIETY: THE SHOW

### THE CAST

Lola .....Lili Taylor  
Rocky .....Oliver Platt  
Sweet Talk Santiago .....Mordecai Santiago  
Sister Margarita .....Roma Maffia  
Sister Cosmo .....Solangee Acosta  
Sister Rob Roy .....Mandy Gonzalez  
Officer Clemente .....David Zayas  
Officer Mendoza .....Alex Tomas  
Tommy .....Anthony Mejia  
Ma .....Jazzlyn Rosado

### LYRICS BY

Willie Reale

### MUSIC BY

Henry Krieger

### DIRECTED BY

Jonathan Bernstein

### MUSIC DIRECTOR

Kari Swenson Riely

### WRITTEN BY

Willie Reale and John Sheehy

### SET CHOREOGRAPHER

Kevin Joseph Roach

### LIGHTING DESIGN

Greg MacPherson and Jason Wells

### COSTUME DESIGN

Crystal Thompson

### SOUND DESIGN

Scott Lehrer

### STAGE MANAGER

Hank Meiman

### FOAMCORE DESIGNS

George Babiak

### MUSIC COPYIST

Kim D. Sherman

## CRIMINAL MASTERMINDS

Arthur Dantchik  
Cathy Dantchik  
Patrice & Louis Friedman, Bear Stearns  
Jenny Wiener & Jon Steingart, Ars Nova  
Jeffrey Yass

## GRAND LARCENERS

Wendy Ettinger & Derek McLane  
Angelina Fiordellisi & Matt Williams  
Cathy & Stephen Graham  
Joanne Woodward & Paul Newman

## HIGHWAY ROBBERS

Bloomberg  
Tom Cruise  
The Dawkins Family Foundation  
Heidi Ettinger  
Alexandra Gersten-Vassilaros & Johnny Coffeeshopolis  
Frances & Colin Greer, The New World Foundation  
Maurice Kanbar  
Fred Nelson, Entertainment Weekly  
Ana Rosa & Peter Phillips, Lloyds TSB  
Maury Schott  
Laura Valeroso & David Seidman  
Wendy vanden Heuvel

## HOLD-UP MEN & WOMEN

Alfred C. Cerullo III	Sonia Manzano & Richard Reagan
Comedy Central	Josephine Merck & Jim Stevenson
Leslie Dantchik	Audrey & Danny Meyer
Mario Egozi	Jane Musky & Tony Goldwyn
Chrysti & David Eigenberg	Rona & Randolph Nelson
Sandi & Andrew Farkas	Jane Perlmutter & Greg MacPherson
Alexa L. Fogel	Anita A. & David S. Rogerson
Nancy Giles	Michael Ritchie
Jane & Jonathan Heine	Steve Sabba
Julia Johns	Leslie Schine & Nils Nilsen
Andrea Johnson	Karen Trott & Peter Herdrich
Mary Kong	Mr. & Mrs. William J. vanden Heuvel
John S. Lyons	Wendy Wasserstein
Grace Lyu-Volckhausen, Tiger Baron Foundation	Brenda Wehle & John C. Lynch



## STICKY FINGERS

Cecilia Arana-Grant & Kevin Grant  
Adam Leitman Bailey  
Becky & Dylan Baker  
June Ballinger & Michael Goldstein  
Ben Barenholtz  
Courtney Baron & Blair Singer  
Lisa Benavides & Tim Nelson  
Myra & Barry Bernard  
Jamie Bernstein  
Vicky Bijur & Ed Levine  
Tessa Blake & Ian Williams  
Jane Bolster & Steve Wertimer  
Katherine Borowitz & John Turturro  
Julie Boyd  
Kathryn Briggs, Dramatists Play Service, Inc.  
Becky Browder & Ted Neustadt  
Deborah Brown  
Michael Buchanan & Marcus Astafan  
Denise Burse & Peter Jay Fernandez  
Cori Cahan & Bernard Gersten  
Colleen Carroll & Mitchell Semel  
Rachel Chanoff  
Sharon Chantiles  
Maddie Corman & Jace Alexander  
Catherine Corpeny & Max D. Mayer  
William Coury  
Anna E. Crouse  
Jennifer Crittendon & Bill Wrubel  
Paula Devicq & Joe Taylor  
Rebecca & Richard Dresser  
Julie Dretzin  
Karen & Christopher Eddowes  
Amy & Gary Ehrlich  
Josephine Eke  
Beth Emelson  
Tom Feeney & Paul Parzuchowski  
Liz Flahive  
Andrew Flatt  
Barbara Fleck-Paladino  
Alison Fraser & Nat Magee  
Janeane Garofalo  
Jenny Gersten &  
Willie Reale  
Jilian Cahan Gersten  
Elizabeth & Paul Giamatti  
Kilty & Lloyd Gilmour  
Bryan Gmitter  
Judy Goldman & Michael Pillinger  
Carol & Larry Goldstein

Amy & George Goldstein  
Mark Gorman & Michael Sporn  
Connie Grappo & Lee Wilkof  
Sarah Grate  
Kimberly Grigsby  
Flavia & Ed Grimm  
Emily Grishman & Susan Sampliner  
Evan Handler  
John Benjamin Hickey  
Amy Herzig  
Katy Homans & Patterson Sims  
Sarah Horowitz & David Venarde  
Barbara Howard  
Jean & Ron Jacobs  
Amanda Johns  
Marcy & Max Kahn  
Sheryl Kaller & Scott Zaretsky  
Sarah Kay & Josh Lewis  
Beth & Seth Klarman  
Belle & Roger Kuhn  
David Kuhn  
Judy Kuhn & David Schwab  
Fran Kumin & Richard Tickin  
Warren Leight  
Robert Sean Leonard  
Liza Lerner  
Douglas Lockwood  
Peter Manning  
Lisa Maris  
Sonya Martin  
Kari McCabe & Nate McBride  
Brigid McCarthy  
Frances McDormand & Pedro Coen  
Andrea, Jon & Julia Miller  
Rebecca Miller & Daniel Day-Lewis  
Suzen Murakoshi & Mark Temme  
Patricia Murphy & Adam Spilka  
Margaret Norden & Joseph Gazdak  
Carol Ochs & Bruce MacVittie  
Jacki Ochs & Jan Kroeze  
Elise Pettus & Dan Algrant  
Jeremy M. Posner  
Christopher Randolph  
Joan Reibman  
Nancy & Fred Rosen  
Rosenzweig & Maffia LLP  
Daryl Roth  
Martha Roth & Bill Irwin  
Joyce Rudnick



Shirley Rumierk  
Tatiana Rutkowsky & Andrew Blackman  
Agnes & Arnold Sametz  
Laura Sametz & Anton Fig  
Tim Sanford  
Stephanie Schaich  
Karin & Thomas Schall  
Erica Schmidt  
Sarah Schulman  
Seret Scott  
Whitney Scott & Peter Jacobson  
Stefan M. Selig  
Robert Shaffron & John Steber  
Sloane Shelton  
Sylvia Shepard & Willy Holtzman  
Landon Slane  
Helen Stambler & James Neuberger  
Abbot Stranahan & David Ward  
Alexandra Styron & Ed Beason  
Susanna Styron & Darrell Larson

Edith Thurber & Kevin O'Rourke  
Lorraine Tobias & Alex Draper  
Anne Torsiglieri & Michael Bernard  
Wendy Townsend & Mark Keoppen  
Maria Tucci & Robert Gottlieb  
Cynthia Vance & Robert Abrams  
Susan J. Vitucci  
Mary Pat Walsh  
Maja Wampuszyc  
Anita Waxman  
Amanda Weil  
Dean Wetherell  
Carol J. Whitesides  
Dana Williams & Don Scardino  
Elizabeth Williams & Joseph Forte  
Rita Wilson & Tom Hanks  
Carole Yass, Randy Ginsburg &  
Jerry Yass  
Yildiz Yuksek & Richard Blackstone  
V.A. Zakian & R.N. Sandberg

List current as of 5/7/03

## THE 52ND STREET PROJECT STAFF

Gus Rogerson, Artistic Director  
Carol Ochs, Executive Director  
John Sheehy, Director of Development and Marketing  
George Babiak, Production Manager  
Megan Sandberg-Zakian, Associate Artistic Director  
Liz Bell, Director of Education  
Chris Ceraso, Teen Dean  
Diana Rojas, Executive Assistant  
Iris A. Brown, Graphic Designer  
Alex Kranz, Intern

## BENEFIT VOLUNTEERS

Heather Carmuff-Gobbée, Perry McBain Daniel, Adam Felber,  
Lucas Fleischer, Danny Goldstein, Zabryna Guevara,  
Eris Migliorini, Catherine Mueller, Kim D. Sherman,  
Jeanne Simpson, Walter Trarbach, Vanessa Valdes, Ed Vassallo

## SPECIAL THANKS

Becky Browder, William Curran, Beth Emelson, Liz Flahive,  
Terry Fitzpatrick, Amy Friedman, Jenny Gersten, Nancy Giles,  
Bryan Gmitter, Mark Jacobs, John Laird, Barbara McCrane,  
Suzen Murakoshi, Stephen Pempeluk, Christopher Randolph,  
Karin & Tom Schall, Mary Pat Walsh

**The 52nd Street Project** is a non-profit organization that brings children from the Hell's Kitchen neighborhood together with professional theater artists to create original theater. The Replay program gives children who are graduates of the Project's Playmaking Class a chance to hone their skills in an advanced writing workshop taught by Megan Sandberg-Zakian. Over the nine weeks of Replay class, these nine young playwrights have explored different sources of inspiration, visiting the park, the theater and an art museum. The resulting plays are featured in tonight's reading.

### Special Thanks

We're grateful to **Steve Olson, Hank Meiman, and The West Bank Cafe** for making this evening possible. The plays wouldn't have made it to the page or the stage without the help of the Replay class volunteers: **Alex Kranz, Edward O'Blenis, Lenore Pemberton, Jolie Tong, Joe Zarrow,** and special guest lecturer, Project Founder **Willie Reale**. Thanks also to Willie for hooking us up with tickets to the best show in town, ***A Year With Frog and Toad***. Thanks to **HCC** for the loan of valuable rehearsal space.

### The Project Staff

Gus Rogerson ..... Artistic Director  
Carol Ochs ..... Executive Director  
John Sheehy ..... Director of Development  
Megan Sandberg-Zakian ..... Associate Artistic Director  
George Roman Babiak ..... Production Manager  
Liz Bell ..... Director of Education  
Diana Rojas ..... Executive Assistant  
Chris Ceraso ..... Teen Dean  
Iris A. Brown ..... Graphic Designer  
Mayleen Cancel, Jaymaree Rosado ..... Receptionists  
Alex Kranz ..... Intern

### The 52nd Street Project Board of Directors

Ben Barenholtz	Carol Ochs
Lisa Benavides	Willie Reale, <i>founder</i>
Rachel Chanoff	Gus Rogerson
Cathy Dantchik	Shirley Rumierk, <i>alumni member</i>
Noël Dawkins	José Soto, Jr., <i>alumni member</i>
Wendy Ettinger, <i>chair emeritus</i>	Pamala Tyson
Louis P. Friedman	Laura Valeroso
Stephen Graham, <i>chair</i>	Wendy vanden Heuvel
Larry Jones	John A. Vassilaros
James McDaniel	Jenny Wiener
Frances McDormand	
Patricia M. Murphy, Esq.	

The 52nd Street Project Presents

---

# THE 2003 REPLAY READING

---

Nine plays by  
nine young playwrights

Monday, June 2, 2003

The Laurie Beechman Theater  
at The West Bank Cafe  
407 West 42nd St., NYC

# THE 2003 REPLAY READING

These plays will be performed without an intermission.

## Violet's Revenge

By Chassity Damiani, age 11

Director: John Sheehy

Violet .....Martha Plimpton  
Old Lady/Mom/Child in City .....Nancy Chatty  
Cloudman .....John Sheehy  
Meltman/Doctor .....Alex Draper

## When Bad Things Go Good

By Mordecai Santiago, age 9

Director: George Babiak

Mike .....Ray Thomas  
Billy .....Doc Dougherty  
Mom .....Phyllis Somerville

## Future World

By Megan Cruz, age 12

Director: Megan Sandberg-Zakian

Andrew/Police .....Joe Zarrow  
Mango .....Myra Lucretia Taylor  
Alexis .....Lenore Pemberton  
Miss Charity/Edith .....Diana Rojas

## Woman and Man

By Yaiana Vasquez Tineo, age 10

Director: Mary Pat Walsh

Mama .....Sonia Manzano  
Man .....Peter Maloney

## Free Will

By Eddie Cuevas, age 13

Director: Dion Graham

B-EZ .....Robert Jimenez  
Mr. Rocafella .....Armando Riesco  
FeeZee/Crowd .....Dion Graham

## Just Because We're Related

Doesn't Mean We Have to Get Along

By Jazzlyn Hernandez, age 12

Director: Seret Scott

Lizette .....Marsha Stephanie Blake  
Justin .....Peter Jacobson  
Carleen Ramos .....Florencia Lozano  
Carleen Ramaros .....Jeanne Simpson

## One Chance

By John Cuevas, age 12

Director: Peter Jay Fernandez

Mike .....Kevin Jackson  
Joey .....Paul Butler  
Vince Carter .....Peter Jay Fernandez  
Mom .....Liz Bell

## Death

By Merlaine Mendez, age 11

Director: Tim Blake Nelson

Charlene .....Lisa Benavides  
Death .....Chris Welch  
Amy/Mom .....Catherine Mueller  
Kids/Doctor .....Tim Blake Nelson

## Gossip Womans

By Christopher Ramirez, age 12

Director: Erica Schmidt

Mrs. Poma .....Kathryn Meisle  
Mrs. Luz .....Kate Forbes  
Mrs. Edward .....Shirley Rumierk  
Mr. Edward/Mr. Luz .....Alex Kranz  
Police .....Jonas Oppenheim

Light Operator and Good Pal: Hank Meiman

Gus Rogerson, Artistic Director

Carol Ochs, Executive Director

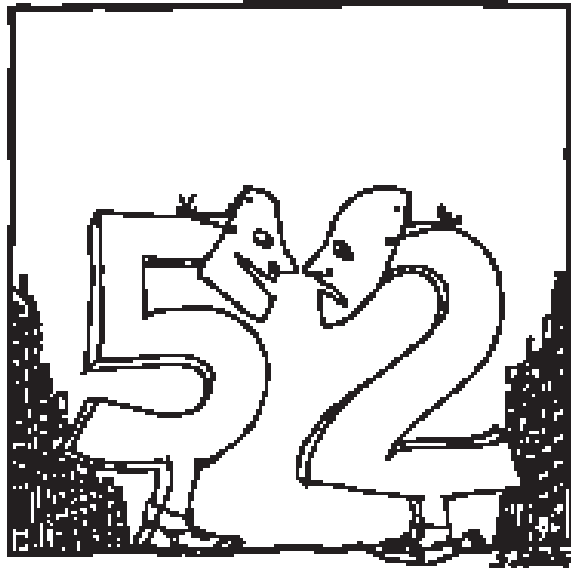

## The 52nd Street Project

*The following foundations and government agencies have generously supported the Teen Program through their contributions:*

City of New York Department of Cultural Affairs  
Horace W. Goldsmith Foundation  
National Endowment for the Arts  
New York State Council on the Arts  
The Surdna Foundation



The 52nd Street Project is a participant in the **New Generations Program**, funded by **Doris Duke Charitable Foundation/The Andrew W. Mellon Foundation** and administered by **Theatre Communications Group**, the national organization for the American theatre.



The 52nd Street Project  
*presents*

# AS YOU LIKE IT

*"Comme Il Vous Plaira"*

By William Shakespeare

Directed by  
Michael Bernard

Adapted by  
Chris Ceraso

and The 52nd Street Project Teens

The  
2003  
World  
Tour

New York City: June 27 - Theater at St. Clement's  
London, England: June 30 - Harrow School  
Lorgues, France: July 4 - Château de Berne



### The 52nd Street Project

The 52nd Street Project (The Project) is dedicated to the creation and production of new plays for, and often by, kids between the ages of ten and eighteen who reside in the Hell's Kitchen neighborhood in New York City. The Project does this through unique mentoring programs that matches kids with professional (and volunteer!) theater artists.

The Project is about making children proud of themselves. The Project is not about teaching children to act, although they will learn to. It is not about teaching them to write plays, although they will learn that as well. What it is about is giving a kid an experience of success. It is about giving a kid an opportunity to prove that he or she has something of value to offer, something that comes from within that he or she alone possesses, something that cannot be taken away.

The Project's Teen Ensemble is the final step in the kids' training: a two-year acting class that culminates in the production of a full-length play by William Shakespeare, the very one you are seeing tonight. This year's show, the most ambitious one to date, takes us to three cities in three countries. We are very grateful to our gracious European hosts for enabling this tour.

### Le Projet de la 52ème Rue

Le Projet de la 52ème Rue est consacré à la création et production de nouvelles pièces de théâtre écrites pour, et souvent par, des jeunes de neuf à dix-huit ans qui habitent le quartier de Hell's Kitchen (Cuisine de L'enfer) à New York. Le Projet apparie ces jeunes avec des artistes de théâtre professionnels qui leur servent de mentor.

Le Projet a pour but principal l'épanouissement de l'amour-propre des enfants. Ce n'est pas une école de théâtre, bien que les enfants deviennent souvent de très bons comédiens et auteurs dramatiques. Le Projet vise plutôt à créer une ambiance dans laquelle l'enfant peut ressentir ce que c'est de réussir. En donnant aux enfants l'occasion de s'exprimer, le Projet les encourage à reconnaître qu'ils ont une voix unique, qu'elle a de la valeur, et qu'elle mérite d'être entendue.

L'Ensemble Adolescent du Projet représente la dernière étape dans la formation des jeunes: un cours de théâtre de deux ans sur l'art de jouer la comédie, menant à la production de la pièce de William Shakespeare à laquelle vous allez assister ce soir. C'est de loin la production la plus ambitieuse que nous avons montée. Elle sera jouée dans trois villes, et trois pays, différents. Nous remercions nos hôtes Européens pour leur générosité, sans laquelle cette tournée n'aurait pas été possible.

## The Cast -L'Ensemble

Orlando	Osage Lewis-Ashley
Adam/Hymen	Michael Bernard
Oliver/Silvius	Matthew Jellison
El Lobo/William	Johnathan Roldan
Rosalind	Mayleen Cancel
Celia	Anju Andre-Bergmann
Touchstone	Noel Polanco
La Belle/ Amelia	Natalie Musteata
Duke Frederick	Chris Ceraso
The Duchess	Nancy Giles
Lady Nancy/ Audrey	Aisha Jabour
Corin/Oliver Martext	George Babiak
Jacklyn/Hisperia	Jennifer Jimenez
Denise/Phebe	Jaya Rosado

Stage Manager: Megan Sandberg-Zakian

Costume Design: Wade Penhorwood

Fight Choreography: Tom Schall

Dance Choreography: Jeanne Simpson

Musical Direction: Josh Lewis

French synopsis translation: Alex Draper

Adult volunteers: Ceci Arana, Catherine Mueller,  
Larry Nathanson, Anne Torsiglieri

The 52nd Street Project would also like to thank  
Harrow School

Bill Muddyman and Jane Muddyman-Heine  
The Staff of the Château de Berne

The 52nd Street Project gratefully acknowledges the support of the following foundations and corporations: Altria Employee Fund, Barker Welfare Foundation, The Barnsley Foundation, Bloomberg, The Blythmore Corporation, California Comedy, Capital Research Company, Carnegie Corporation of New York, Citigroup Foundation, Comedy Central, Davis Polk & Wardwell, Deutsche Bank of Americas Foundation, The Dramatists Guild Fund, Dramatists Play Service, Eleanor, Adam & Mel Dubin Foundation, Entertainment Weekly, The Fan Fox & Leslie R. Samuels Foundation, The J. Paul Getty Trust, The Horace W. Goldsmith Foundation, The William and Mary Greve Foundation, The Hennessy Foundation, Holland Lodge Foundation, Inc., Betty E. & George B. Kaiser Foundation, Lemberg Foundation, Inc., Lloyds TSB Bank plc, Lucent Technologies, Lucille Lortel Foundation, James A. Macdonald Foundation, Major League Baseball, Ann M. Martin Foundation, Mellon Bank, N.A., The Cynthia & George Mitchell Foundation, The National Board of Review, The New World Foundation, The New York Times Company Foundation, Newman's Own, Norcross Wildlife Foundation, Inc., Stranahan Foundation, Susquehanna Partners, G.P., Theatre Communications Group, Inc., Paramount Pictures, John A. Vassilaros & Son, Inc., The Vervane Foundation, The Wiener Family Foundation, Zagat Survey, Felix Zaremba & Co. Inc., In addition the following individuals made gifts of over \$200 to The 52nd Street Project this year (list is current as of 6/30/03):

Anonymous	Martin Fetner & William Coury	Kate Lear & Jonathan LaPook	Daryl Roth
Robert Abrams & Cynthia Vance	Angelina Fiordellisi	Mary Ann Lefort	Martha Roth & Bill Irwin
Jace Alexander & Maddie Corman	Liz Flahive	Warren Leight	Mark Saad
Alexis Alexanian	Anita Flanagan & Jeff Potter	Liza Lerner	Steve Sabba
Cecilia Arana-Grant & Kevin Grant	Alexa Fogel	Joshua Lewis & Sarah Kay	Arnold & Agnes Sametz
Lucie Amaz & Laurence Luckinbill	Frank Frattaroli	Anna Li	Laura Sametz & Anton Fig
Debbon Ayer	Helen B. Freedman	Linda Li	Don Scardino & Dana Williams
Adam Leitman Bailey	Katherine Freedman	Adrienne Lobel & Mark Linn Baker	Zeborah Schachtel
Dylan & Becky Baker	Naomi Freundlich & Charles Miles	Doug Lockwood	Karin & Tom Schall
June Ballinger & Michael Goldstein	Louis & Patrice Friedman	John Lyons	Leslie Schine & Nils Nilsen
Ben Barenholtz	Janeane Garofalo	Grace Lyu-Volkhausen	Mauri Schott
Benny Bartley	Rose Gasner & Larry Chertoff	Barry Mackall &	Ken & Mary Ann Schuster
Jessica Bauman	Cora Cahan & Bernard Gersten	Bill Schwinghammer	Seret Scott
Laurie Becker & Rick Sweren	Lillian Cahan Gersten	Marsue & Peter MacNicol	Stefan Selig
Meredith Beeuwkes	Ileen Getz & Mark Grinnell	Greg MacPherson &	Mitchell Sernel & Colleen Carroll
Lisa Benavides & Tim Nelson	Paul & Liz Giamatti	Jane Perlmutter	Tom Shadyac
Vicky Bijur & Ed Levine	Nancy Giles	Joseph Maffia	Aaron & Elaine Shapiro
Lewis Black	Lloyd & Kitty Gilmour	Nat Magee & Alison Fraser	Bernice Baruch Shawl
Richard Blackstone &	Bryan Gmitter	Wendy Makkena & Bob Krakower	Sloane Shelton & Jan Buckaloo
Yldeez Yuksek	Judy Goldman & Michael Pillingier	Paul & Lauren Mandell	Abby Jo Sigal & Matt Turner
Tessa Blake	George & Amy Goldstein	Elizabeth Manne	Meg Simon
Katherine & John Borowitz	Larry & Carol Goldstein	Sonia Manzano &	Landon Slane
Buzz Boyshow	Tony Goldwyn & Jane Musky	Richard Reagan	Talia Balsam & John Slattery
Julie Boyd	Fred & Nancy Goodman	Donald Margulies & Lynn Street	Abigail Rose Solomon
Bob Boyett	Stephen & Cathy Graham	Richard Marin	Phyllis Somerville
Kathy Briggs	Connie Grappo & Lee Wilkof	Sonya Martin	John Steber & Robert Shaffron
Becky Browder & Ted Neustadt	Michael Greif & Jonathan Fried	Kay Matschullat & Allan Arfa	Jean Stein
Susan Bruce & Peter Hedges	Emily Grishman &	George Mayer	Ben & Christine Stiller
Michael Buchanan &	Susan Sampliner	Brigid McCarthy	David & Sara Stone
Marcus Astafan	Lisa Gugenheim	Paul McCrane & Dana Kellin	Abby Stranahan & Dave Ward
Kate Burton & Michael Ritchie	Mark & Valerie Hadjipateras	Fran McDormand & Joel Coen	Alexandra Styron & Ed Beason
Alfred C. Cerullo III	Marianne Hagan	William Michael McMahon &	Susanna Styron & Darrell Larson
Rachel Chanoff	Evan Handler	Meg McMahon	Brian Swardstrom & Bonnie
Sharon Chantile	Lynn E. Harris	Rick Meese & Dan Lori	Bernstein
Glenda Chesshir	Jane & Jonathan Heine	Richard & Denise Menelly	Daniel Swade
Kirk & Katherine Holt Citron	Peter Herdrich & Karen Trott	Josie Merck & Jim Stevenson	Mariko Tada
Darah Cloud & Dave Owens	Amy Herzig	Brian Mertes	Gina Torres
Ruth Cohen	William Holtzman &	Audrey & Danny Meyer	Anne Torsiglieri &
Lieta Heslen-Cohen &	S. Sylvia Shepard	Nancy Meyer & Marc Weiss	Michael Bernard
Richard Cohn	Katy Homans & Patterson Sims	Neal & Amanda Moszkowski	Liz Tucello
Tricia Cooke & Ethan Coen	Sarah Horowitz & David Venarde	Suzen Murakoshi & Mark Temme	John & Katherine Turturro
Hyla & Richard Crane	Barbara Howard	Patricia M. Murphy, Esq. &	Laura Valeroso & David Seidman
Margaret Crimmins	Philip & Alexandra Howard	Adam Spilka	Josephine Eke & Jason Valk
Billy Crudup & Mary Louise Parker	Kate Hudson & Chris Robinson	Don & Sara Nelson	Wendy vanden Heuvel &
Tom Cruise	Dana Ivey	Pamela & Peter Nelson	Brad Coley
Catherine Curtin	Jean & Ron Jacobs	Randy & Rona Nelson	William & Melinda vanden Heuvel
Willem Dafoe & Liz Lecompte	Mark Evan Jacobs	Ruth Nelson	Ed Vassallo
Arthur Dantchik	Sy Jacobs	Mark Nesselson, M.D. &	John A. Vassallo
Cathy Dantchik	Whitney Scott & Peter Jacobson	Elliott Rosenblum	Susan Vitucci
Leslie Dantchik	Linda LeRoy Janklow	James Neuberger &	Mary Pat Walsh
Peter & Judith Dawkins	Amanda Johns	Helen Stambler	Ms. Valerie Walsh
Georgia & William Delano	Julia A. Johns	Lori O'Connor	Maja Wampuszyc
Jonathan Demme	Andrea Johnson	Kevin O'Rourke & Edith Thurber	Wendy Wasserstein
Buddy Dikman & Chuck Davis	Traci Paige Johnson &	Carol Ochs & Bruce MacVittie	Anita Waxman
Edward & Joanne DiRugenis	Robert Mowen	Jacki Ochs & Jan Kroeze	Brenda Wehle & John C. Lynch
Alex Draper & Lorraine Tobias	Larry & Mary Jones	Paul & Maria Onderdonk	Sally & Lenny Weiss
Richard & Rebecca Dresser	Marcy & Max Kahn	Joe Paladino &	Jane Bolster & Steve Wertimer
Christopher & Karen Eddowes	Sheryl Kaller	Barbara Fleck-Paladino	Carol Whitesides
Mario Egozi	Maurice Kanbar	Elizabeth Peters	Jenny Wiener & Jon Steingart
David & Chrysti Eigenberg	Eric Karpeles & Mike Sell	Peter & Ana Rosa Phillips	Michael & Zena Wiener
Ned Eisenberg & Patricia Maguire	Ronald Kastner & Vanessa Boeoye	Oliver Platt &	Elizabeth Williams & Joseph Forte
Beth Emelson	Stephen & Sharon Kepniss	Camilla Campbell Platt	Donald Windham
Nora Ephron	Seth & Beth Klarman	Jeremy Posner	John Woo
Barbara Ettinger & Sven Huseby	Mary Kong	Dean & Leslie Potashner	Joanne Woodward &
Heidi Ettinger	Sarah & Steven Kraemer	Peter & Helen Randolph	Paul Newman
Wendy Ettinger & Derek McLane	Judy Kuhn & David Schwab	Willie Reale & Jenny Gersten	Bill Wrubel & Jennifer Crittenden
Andrew & Sandi Farkas	Roger & Belle Kuhn	Theresa Rebeck & Jess Lynn	Carolee Yass & Randy Ginsburg
Tom Feeney & Paul Parzuchowski	Frances Kumin & Richard Ticktin	Herald & Linda Ritch	Jeffrey & Janine Yass
Peter Jay Fernandez &	Allan & Nanette Larson	David & Anita Rogerson	James & Mary Lin Yoshimura
Denise Burse	Michael P. Lawrence	Robin Morse & Gus Rogerson	Virginia Zakian & Robert Sandberg

The 52nd Street Project presents  
The 2003 Harold and Mimi Steinberg Charitable Trust One-on-Ones

# DATES WITH DESTINY THE HISTORIC PLAYS

**THE BLOCK ISLAND CHRONICLES**



JAMES STEVENSON

July 24-27, 2003  
The Ensemble Studio Theatre  
549 West 52nd St.  
NEW YORK CITY

# DATES WITH DESTINY THE HISTORIC PLAYS

The 2003 Block Island  
One-on-Ones  
July 24-27  
The Ensemble  
Studio Theatre

## The 52nd Street Project Staff:

Gus Rogerson, Artistic Director  
Carol Ochs, Executive Director  
John Sheehy, Director of Development and Marketing  
Megan Sandberg-Zakian, Associate Artistic Director  
George "X-Acto" Babiak, Production Manager  
Liz Bell, Director of Education  
Diana Rojas, Executive Assistant  
Chris Ceraso, Teen Dean  
Iris A. Brown, Graphic Designer  
Mayleen Cancel and Jaymaree Rosado, Receptionists  
Interns: Melissa Jones and Melissa Gawlowski

## Production Staff

**Composer:** Kim D. Sherman  
**Set Designer:** Kevin Joseph Roach  
**Lighting Designer:** Greg MacPherson  
**Costume Designer:** Crystal Thompson  
**Costume Assistant:** Jennifer Jimenez  
**Sound Designer:** Betsy Rhodes  
**Stage Manager:** Kelly Blackwell  
**Slide Design Team:**

Chris Bonanos, Johann Conforme,  
Lee Kimble, Katherine Lumb,  
Kathleen Maloney, Mike Marshall, Robin  
Marshall, Monty Nicol, John Steward,  
Alberta Testanero, Iwona Waluk

## Prop Design Team:

Anju Andre-Bergmann, George Babiak,  
Chris Bonanos, Heather Camduff-Gobbée,  
Leah Cumey, Bree Elrod, Paul Boyd,  
Charlie LaGreca, Jeff LaGreca,  
Katherine Lumb, Monty Nicol,  
Erin Quinn Purcell, Christopher Ramirez,  
John Sheehy

## Flyer/Program Illustrations:

James Stevenson

## Furniture Boss:

Alex Tomas

## Furniture Crew:

Anthony Mejia,  
Timothy Thomas

## Prop Crew:

Melissa Jones, Melissa Gawlowski,  
Anju Andre-Bergmann

## Load-in and Light-hang Crew:

Anju Andre-Bergmann,  
Kelly Blackwell, Bree Elrod,  
Jeff LaGreca, Karen Munkel,  
Doug Nervik, Tom Schall,  
Ed Vassallo

## House Managers:

Liz Bell, Liz Flahive

## Chefs:

Pat McQuade and  
Martha Velie-Gass

## Teen Counselor:

Anju Andre-Bergmann



NATIONAL  
ENDOWMENT  
FOR THE ARTS

The One-on-Ones Program is made possible with public funds from the National Endowment for the Arts; The New York State Council on the Arts, a state agency; the Department of Youth and Community Development; and the New York City Department of Cultural Affairs. The 52nd Street Project is a member of ART/NY and a participant in the New Generations Program, funded by Doris Duke Charitable Foundation/The Andrew W. Mellon Foundation and administered by Theatre Communications Group, the national organization for the American Theater.

State of the Arts



NYS CA

## COOL STUFF ON SALE IN THE LOBBY!

The Fabulous Flyer Bar .....\$2.00 & \$1.50  
and featuring Shel Silverstein's "Fivey and Twoey" logo:  
Project T-shirts .....\$12.00  
Project Tank Tops .....\$12.00  
Project Caps (NEW design) .....\$15.00  
Project Mugs (now in BLUE!) .....\$5.00  
Project Pencil 3-pack (now in RED!) .....\$1.00

Thank you for coming to **DATES WITH DESTINY!** If you are not on our mailing list (or if your address has changed), please fill out this form and give it to us on your way out or mail it to the address below. We would also like to know if you are interested in becoming a volunteer. We need help in **all areas**, so be sure to fill out the entire form.

### PLEASE ADD ME TO YOUR MAILING LIST:

7/03

NAME: \_\_\_\_\_

ADDRESS: \_\_\_\_\_

ZIP \_\_\_\_\_

HOME PHONE: \_\_\_\_\_

DAYTIME PHONE: \_\_\_\_\_

E-MAIL ADDRESS: \_\_\_\_\_

MY OCCUPATION: \_\_\_\_\_

MY HOBBIES: \_\_\_\_\_

### YES, I WOULD LIKE TO BE OF HELP. I CAN:

- |   |   |  |
|---|---|--|
| <input type="checkbox"/> Help load in and out for shows | <input type="checkbox"/> Draw and/or paint  | <input type="checkbox"/> Help kids with homework |
| <input type="checkbox"/> Hang lights                    | <input type="checkbox"/> Help with mailings | <input type="checkbox"/> Teach kids a skill      |
| <input type="checkbox"/> Work on a backstage crew       | <input type="checkbox"/> Do office work     | <input type="checkbox"/> Be a chef at an event   |
| <input type="checkbox"/> Do graphic design              | <input type="checkbox"/> Design sound       | <input type="checkbox"/> Design and sew costumes |
| <input type="checkbox"/> Other (please specify) _____   |   |  |

### MY SCHEDULE IS:

- Very flexible. I'm often available during weekdays.  
 Somewhat flexible. I can help on the occasional morning or afternoon during the week.  
 Not very flexible at all, but I've got some free time on evenings and weekends.

If you would like to mail this (and you're always welcome to enclose a tax-deductible contribution), you can send it to: **The 52nd Street Project**, 500 West 52nd St., New York, NY 10019. Or fax it to (212) 333-5598.

**Don't Miss Our Upcoming Shows!**

# ***SECOND DATES WITH DESTINY***

**THE WAREHAM CHRONICLES**



The second outing of the 2003 One-on-Ones  
August 21-24 right here at E.S.T.  
Same great theme, but with new kids,  
new adults, and all-new plays. Come again!

## **PLAYBACK**

**November, 2003**

First a kid writes a short play. Then, an adult writes an "answer" play. Then, the two of them perform both plays. Multiply this equation by seven and you've got an entire show.



**December, 2003**

In September, 10 kids brand-new to the Project will begin a Playmaking class taught by Project Playmaking Director Megan Sandberg-Zakian. Come and see their final plays performed by adult professional actors.

The 52nd Street Project is a non-profit organization that brings children from the Hell's Kitchen neighborhood together with professional theater artists to create original theater. **DATES WITH DESTINY** is a production of our One-on-One program, which is designed to give children the opportunity to go away for one-week stays in the country and enjoy the undivided attention of a professional theater artist who serves as friend, mentor, and collaborator. The Project is delighted to return to the Ensemble Studio Theatre, where we have been performing since our inception in 1981. We gratefully acknowledge the fact that if E.S.T. wasn't here, we'd be nowhere.

### **The 52nd Street Project Board of Directors**

Ben Barenholtz  
Lisa Benavides  
Rachel Chanoff  
Cathy Dantchik  
Noël Dawkins

Wendy Ettinger, *chair emeritus*  
Louis P. Friedman  
Stephen Graham, *chair*  
Larry Jones  
James McDaniel  
Frances McDormand

Patricia M. Murphy, Esq.  
Carol Ochs  
Willie Reale, *founder*  
Gus Rogerson  
Shirley Rumierk, *alumni member*  
José Soto, Jr., *alumni member*  
Pamala Tyson  
Laura Valeroso  
Wendy vanden Heuvel  
John A. Vassilaros  
Jenny Wiener

### **Special Thanks**

Our Host Families – Pat McQuade & Martha Velie-Gass; Josie Merck & Jim Stevenson; Eliot & Amy Nerenberg; Jennifer & Elliot Taubman; Diane Trippler & Don Frageau; Ron, Judy & Kevin Tierney; Joya Verde & Virginia Dare; Thomas Frye and our headquarters host Dr. Christina Biaggi. Sincere thanks also go to Lynn Reale, Kate & Harold at Block Island Realty; Prudy & The Ice Cream Place; Rita & Steve Draper; Jane Muskey & Tony Goldwyn; Glenn & Annie Hall; McQuade's Market; Interstate Navigation; Sophia Ochs MacVittie; Jenny Ritter; Amanda Gass; Kirk Littlefield; Joe and Pat at Smuggler's Cove Sailing School; Finns, Block Island Grocery and The Depot.

### **In-Kind Contributions**

Curt, Jamie, Suzanne, Carl, Tim, and everyone at the Ensemble Studio Theatre; Neil A. Mazzella and Hudson Scenic Studios; the Murphy Law Office; Stephanie Berger; Iris A. Brown; Ron Kastner and Capital Printing; Kenneth Cole Productions; Noggin; The Printing Store; Scholastic, Inc.; Diageo Chateau & Estate Wines; Entertainment Weekly; Alison Fraser; Newman's Own; Sesame Workshop; Wendy Stuhlberg; Tarte, Inc.; Terax America; John A. Vassilaros; Watkins, Inc.; Mayor's Office of Film & Television; Boylan's Bottling Co.; David Sneddon & Fairway Market; Andy Millon; Steve Olsen & The Westbank Cafe; Lorraine Tobias & Imaginary Studios; Jive Records, part of Zomba Music Group; and Prime Films.

## DATES WITH DESTINY - ACT 1

All original music composed by Kim D. Sherman  
"Dates With Destiny Theme Song" lyrics by John Sheehy

### WHERE'S THE SOOTH IN THAT?

Written by Liz Flahive & Directed by Diana Rojas for Chassity Damiani, age 11

Millie .....Chassity Damiani  
Madge .....Diana Rojas  
Jim .....George Babiak  
Ancient Voices .....Erin Quinn Purcell, Melissa Jones,  
Bree Elrod, Eris Migliorini

"I Like What I See" lyrics by Liz Flahive

### A SHORT HISTORY OF AN ODD DAY

Written by Neena Beber & Directed by Florencia Lozano for  
Crystal Toro, age 11 (on July 25)

Lulubelle .....Crystal Toro  
Fifi .....Florencia Lozano  
Cheerleaders .....Anju Andre-Bergmann, Melissa Jones, Liz Bell

"When You Get Stuck" lyrics by Neena Beber

### BATTLEFIELD BLUES

Written & Directed by Jonas Oppenheim for Zebulun Santiago, age 12

Joey .....Zebulun Santiago  
Jimmy .....Jonas Oppenheim

"The 'I'm Scared' Song" lyrics by Jonas Oppenheim

### THE QUEEN OF BASEBALL

Written & Directed by Gus Rogerson for Merlaine Mendez, age 11

Lizzie "Spike" Murphy .....Merlaine Mendez  
Batboy .....Gus Rogerson  
Kid with letter .....Alex Tomas  
Play-by-Play .....George Babiak

"The Best in Baseball" lyrics by Gus Rogerson

### CREW OF TWO

Written & Directed by Eris Migliorini for Michael Velez, age 13

First Mate Buster McMean .....Michael Velez  
Captain Bonecruncher .....Eris Migliorini  
Miss Wogg .....Melissa Jones  
Captain Crazyhair .....Anju Andre-Bergmann  
The Crew .....The Crew

"Pirates" lyrics by Eris Migliorini

👉 **Intermission!** 👈

## DATES WITH DESTINY - ACT 2

### TWO GENTS OF WHENCE

Written by Willie Reale & Directed by Victor Rojas for  
Christopher Ramirez, age 13

Spence .....Christopher Ramirez  
Impetigo .....Victor Rojas

"Heather" and "Me" lyrics by Willie Reale

### JANET'S DATE WITH DESTINY

Written by James Stevenson & Directed by Dion Graham for  
Christine Tomas, age 10

Janet .....Christine Tomas  
Gary and Voice of God .....Dion Graham

"Invention" and "Tell Me A Joke" lyrics by James Stevenson

### WHO DIED AND MADE YOU PRESIDENT?

Written by Madeleine George & Directed by Bree Elrod for  
Nicole Fargardo, age 12

Candace Kominsky .....Nicole Fargardo  
April Rose Smith .....Bree Elrod  
Miss DiRafael .....Melissa Gawlowski

"My Fellow Americans" lyrics by Madeleine George

### THE YUMMY MUMMY

Written & Directed by Erin Quinn Purcell for Skye Blu Welsh, age 12

Miss Aurora Mariette Birch .....Skye Blu Welsh  
Professor Emily Hemmingspot .....Erin Quinn Purcell  
King Tootsanapplepeel .....George Babiak

"Date with a Mummy" lyrics by Erin Quinn Purcell

### PANEL DISCUSSION

Written & Directed by John Sheehy for Harlo Ulloa, age 10

The Raven Lunatic .....Harlo Ulloa  
Captain Heroic Goodman .....John Sheehy



The 52nd Street Project gratefully acknowledges the support of the following foundations and corporations: Altria Employee Fund, Barker Welfare Foundation, The Barnsley Foundation, Bloomberg, The Blythmore Corporation, California Comedy, Capital Research Company, Carnegie Corporation of New York, Citigroup Foundation, Comedy Central, Davis Polk & Wardwell, Deutsche Bank of Americas Foundation, The Dramatists Guild Fund, Dramatists Play Service, Eleanor, Adam & Mel Dubin Foundation, Entertainment Weekly, The Fan Fox & Leslie R. Samuels Foundation, The J. Paul Getty Trust, The Horace W. Goldsmith Foundation, The William and Mary Greve Foundation, The Hennessy Foundation, Holland Lodge Foundation, Inc., Betty E. & George B. Kaiser Foundation, Lemberg Foundation, Inc., Lloyds TSB Bank plc, Lucent Technologies, Lucille Lortel Foundation, James A. Macdonald Foundation, Major League Baseball, Ann M. Martin Foundation, Mellon Bank, N.A., The Cynthia & George Mitchell Foundation, The National Board of Review, The New World Foundation, The New York Times Company Foundation, Newmar's Own, Norcross Wildlife Foundation, Inc., Stranahan Foundation, Susquehanna Partners, G.P., Theatre Communications Group, Inc., Paramount Pictures, John A. Vassilaros & Son, Inc., The Vervane Foundation, The Wiener Family Foundation, Zagat Survey, Felix Zaremka & Co. Inc., In addition the following individuals made gifts of over \$200 to The 52nd Street Project this year (list is current as of 6/30/03):

Anonymous	Martin Fetner & William Coury	Kate Lear & Jonathan LaPook	Daryl Roth
Robert Abrams & Cynthia Vance	Angelina Fiordellisi	Mary Ann Lefort	Martha Roth & Bill Irwin
Jace Alexander & Maddie Corman	Liz Flahive	Warren Leight	Mark Saad
Alexis Alexanian	Anita Flanagan & Jeff Potter	Liza Lerner	Steve Sabba
Cecilia Arana-Grant & Kevin Grant	Alexa Fogel	Joshua Lewis & Sarah Kay	Arnold & Agnes Sametz
Lucie Amaz & Laurence Luckinbill	Frank Frattaroli	Anna Li	Laura Sametz & Anton Fig
Debbon Ayer	Helen B. Freedman	Linda Li	Don Scardino & Dana Williams
Adam Leitman Bailey	Katherine Freedman	Adrienne Lobel & Mark Linn Baker	Zeborah Schachtel
Dylan & Becky Baker	Naomi Freundlich & Charles Miles	Doug Lockwood	Karin & Tom Schall
June Ballinger & Michael Goldstein	Louis & Patrice Friedman	John Lyons	Leslie Schine & Nils Nilsen
Ben Barenholtz	Janeane Garofalo	Grace Lyu-Volkhausen	Maurly Schott
Benny Bartley	Rose Gasner & Larry Chertoff	Barry Mackall &	Ken & Mary Ann Schuster
Jessica Bauman	Cora Cahan & Bernard Gersten	Bill Schwinghammer	Seret Scott
Laurie Becker & Rick Sweren	Jilian Cahan Gersten	Marsue & Peter MacNicol	Stefan Selig
Meredith Beeuwkes	Ileen Getz & Mark Grinnell	Greg MacPherson &	Mitchell Sernel & Colleen Carroll
Lisa Benavides & Tim Nelson	Paul & Liz Giamatti	Jane Perlmutter	Tom Shadyac
Vicky Bijur & Ed Levine	Nancy Giles	Joseph Maffia	Aaron & Elaine Shapiro
Lewis Black	Lloyd & Kitty Gilmour	Nat Magee & Alison Fraser	Bernice Baruch Shawl
Richard Blackstone &	Bryan Gmitter	Wendy Makkena & Bob Krakower	Sloane Shelton & Jan Buckaloo
Yldeez Yuksek	Judy Goldman & Michael Pillingier	Paul & Lauren Mandell	Abby Jo Sigal & Matt Turner
Tessa Blake	George & Amy Goldstein	Elizabeth Manne	Meg Simon
Katherine & John Borowitz	Larry & Carol Goldstein	Sonia Manzano &	Landon Slane
Buzz Bovshow	Tony Goldwyn & Jane Musky	Richard Reagan	Talia Balsam & John Slattery
Julie Boyd	Fred & Nancy Goodman	Donald Margulies & Lynn Street	Abigail Rose Solomon
Bob Boyett	Stephen & Cathy Graham	Richard Marin	Phyllis Somerville
Kathy Briggs	Connie Grappo & Lee Wilkof	Richard Marin	John Steber & Robert Shaffron
Becky Browder & Ted Neustadt	Michael Greif & Jonathan Fried	Kay Matschullat & Allan Arfa	Jean Stein
Susan Bruce & Peter Hedges	Emily Grishman &	George Mayer	Ben & Christine Stiller
Michael Buchanan &	Susan Sampliner	Brigid Mccarthy	David & Sara Stone
Marcus Astafan	Lisa Gugenheim	Paul McCrane & Dana Kellin	Abby Stranahan & Dave Ward
Kate Burton & Michael Ritchie	Mark & Valerie Hadjipateras	Fran McDormand & Joel Coen	Alexandra Styron & Ed Beason
Alfred C. Cerullo III	Marianne Hagan	William Michael McMahon &	Susanna Styron & Darrell Larson
Rachel Chanoff	Evan Handler	Meg McMahon	Brian Swardstrom & Bonnie
Sharon Chantile	Lynn E. Harris	Rick Meese & Dan Lori	Bernstein
Glenda Chesshir	Jane & Jonathan Heine	Richard & Denise Menelly	Daniel Wade
Kirk & Katherine Holt Citron	Peter Herdrich & Karen Trott	Josie Merck & Jim Stevenson	Mariko Tada
Darah Cloud & Dave Owens	Amy Herzig	Brian Mertes	Gina Torres
Ruth Cohen	William Holtzman &	Audrey & Danny Meyer	Anne Torsiglieri &
Lieta Heslen-Cohen &	S. Sylvia Shepard	Nancy Meyer & Marc Weiss	Michael Bernard
Richard Cohn	Katy Homans & Patterson Sims	Neal & Amanda Moszkowski	Liz Tuccillo
Tricia Cooke & Ethan Coen	Sarah Horowitz & David Venarde	Suzen Murakoshi & Mark Temme	John & Katherine Turturro
Hyla & Richard Crane	Barbara Howard	Patricia M. Murphy, Esq. &	Laura Valeroso & David Seidman
Margaret Crimmins	Philip & Alexandra Howard	Adam Spilka	Josephine Eke & Jason Valk
Billy Crudup & Mary Louise Parker	Kate Hudson & Chris Robinson	Don & Sara Nelson	Wendy vanden Heuvel &
Tom Cruise	Dana Ivey	Pamela & Peter Nelson	Brad Coley
Catherine Curtin	Jean & Ron Jacobs	Randy & Rona Nelson	William & Melinda vanden Heuvel
Willem Dafoe & Liz Lecompte	Mark Evan Jacobs	Ruth Nelson	Ed Vassallo
Arthur Dantchik	Sy Jacobs	Mark Nesselson, M.D. &	John A. Vassallo
Cathy Dantchik	Whitney Scott & Peter Jacobson	Elliott Rosenblum	Susan Vitucci
Leslie Dantchik	Linda LeRoy Janklow	James Neuberger &	Mary Pat Walsh
Peter & Judith Dawkins	Amanda Johns	Helen Stambler	Ms. Valerie Walsh
Georgia & William Delano	Julia A. Johns	Lori O'Connor	Maja Wampuszyc
Jonathan Demme	Andrea Johnson	Kevin O'Rourke & Edith Thurber	Wendy Wasserstein
Buddy Dikman & Chuck Davis	Traci Paige Johnson &	Carol Ochs & Bruce MacVittie	Anita Waxman
Edward & Joanne DiRugenis	Robert Mowen	Jacki Ochs & Jan Kroeze	Brenda Wehle & John C. Lynch
Alex Draper & Lorraine Tobias	Larry & Mary Jones	Paul & Maria Onderdonk	Sally & Lenny Weiss
Richard & Rebecca Dresser	Marcy & Max Kahn	Joe Paladino &	Jane Bolster & Steve Wertimer
Christopher & Karen Eddowes	Sheryl Kaller	Barbara Fleck-Paladino	Carol Whitesides
Mario Egozi	Maurice Kanbar	Elizabeth Peters	Jenny Wiener & Jon Steingart
David & Chrysti Eigenberg	Eric Karpeles & Mike Sell	Peter & Ana Rosa Phillips	Michael & Zena Wiener
Ned Eisenberg & Patricia Maguire	Ronald Kastner & Vanessa Boeoye	Oliver Platt &	Elizabeth Williams & Joseph Forte
Beth Emelson	Stephen & Sharon Kepniss	Camilla Campbell Platt	Donald Windham
Nora Ephron	Seth & Beth Klarman	Jeremy Posner	John Woo
Barbara Ettinger & Sven Huseby	Mary Kong	Dean & Leslie Potashner	Joanne Woodward &
Heidi Ettinger	Sarah & Steven Kraemer	Peter & Helen Randolph	Paul Newman
Wendy Ettinger & Derek McLane	Judy Kuhn & David Schwab	Willie Reale & Jenny Gersten	Bill Wrubel & Jennifer Crittenden
Andrew & Sandi Farkas	Roger & Belle Kuhn	Theresa Rebeck & Jess Lynn	Carolee Yass & Randy Ginsburg
Tom Feeney & Paul Parzuchowski	Frances Kumin & Richard Ticktin	Herald & Linda Ritch	Jeffrey & Janine Yass
Peter Jay Fernandez &	Allan & Nanette Larson	David & Anita Rogerson	James & Mary Lin Yoshimura
Denise Burse	Michael P. Lawrence	Robin Morse & Gus Rogerson	Virginia Zakian & Robert Sandberg

The 52nd Street Project presents  
The 2003 Wiener Family Foundation One-on-Ones

# SECOND DATES WITH DESTINY THE HISTORIC PLAYS

THE WAREHAM CHRONICLES



JAMES STEVENSON

August 21-24, 2003  
The Ensemble Studio Theatre  
549 West 52nd St.  
NEW YORK CITY

# DATES WITH DESTINY THE HISTORIC PLAYS

The 2003 Wareham, MA  
One-on-Ones  
August 21-24  
The Ensemble  
Studio Theatre

## The 52nd Street Project Staff:

Gus Rogerson, Artistic Director  
Carol Ochs, Executive Director  
John Sheehy, Director of Development and Marketing  
Megan Sandberg-Zakian, Associate Artistic Director  
George "X-Acto" Babiak, Production Manager  
Liz Bell, Director of Education  
Diana Rojas, Executive Assistant  
Chris Ceraso, Teen Dean  
Iris A. Brown, Graphic Designer  
Mayleen Cancel and Jaymaree Rosado, Receptionists  
Interns: Melissa Jones and Melissa Gawlowski

## Production Staff

**Composer:** Patrick Barnes  
**Set Designer:** Kevin Joseph Roach  
**Lighting Designer:**  
Greg MacPherson  
**Costume Designer:**  
Crystal Thompson  
**Camel Head Design & Construction:**  
Erminio Pinque & Big Nazo Designs  
**Sound Designer:** Vanessa Valdes  
**Stage Manager:** Karen Munkel  
**Slide Design Team:**  
George Babiak, Midge Lucas and guest  
artists of the past  
**Prop Design Team:**  
George Babiak, Heather Camduff-  
Gobbée, Britney Castro, Melissa  
Gawlowski, Esther Geller, Midge Lucas,  
Isayah Muller, Karen Munkel, Octavia  
Rodriguez, Mordecai Santiago, Amanda  
Santos, John Sheehy, Alex Tomas

## Flyer/Program Illustrations:

James Stevenson

## Furniture Crew:

Nash Landesman,  
Anthony Mejia

## Prop Crew:

Melissa Jones,  
Melissa Gawlowski,  
Suzette Santana

## Load-in and Light-hang Crew:

Karen Munkel,  
Ed Vassallo

## House Managers:

Liz Bell,  
Liz Flahive

## Chefs:

Carol Ochs,  
Christopher Randolph,  
John Sheehy

## COOL STUFF ON SALE IN THE LOBBY!

The Fabulous Flyer Bar .....\$2.00 & \$1.50  
and featuring Shel Silverstein's "Fivey and Twoey" logo:  
Project T-shirts .....\$12.00  
Project Tank Tops .....\$12.00  
Project Caps (NEW design) .....\$15.00  
Project Mugs (now in BLUE!) .....\$5.00  
Project Pencil 3-pack (now in RED!) .....\$1.00

Thank you for coming to **SECOND DATES WITH DESTINY!** If you are not on our mailing list (or if your address has changed), please fill out this form and give it to us on your way out or mail it to the address below. We would also like to know if you are interested in becoming a volunteer. We need help in **all areas**, so be sure to fill out the entire form.

### PLEASE ADD ME TO YOUR MAILING LIST:

8/03

NAME: \_\_\_\_\_

ADDRESS: \_\_\_\_\_

ZIP \_\_\_\_\_

HOME PHONE: \_\_\_\_\_

DAYTIME PHONE: \_\_\_\_\_

E-MAIL ADDRESS: \_\_\_\_\_

MY OCCUPATION: \_\_\_\_\_

MY HOBBIES: \_\_\_\_\_

### YES, I WOULD LIKE TO BE OF HELP. I CAN:

- |   |   |  |
|---|---|--|
| <input type="checkbox"/> Help load in and out for shows | <input type="checkbox"/> Draw and/or paint  | <input type="checkbox"/> Help kids with homework |
| <input type="checkbox"/> Hang lights                    | <input type="checkbox"/> Help with mailings | <input type="checkbox"/> Teach kids a skill      |
| <input type="checkbox"/> Work on a backstage crew       | <input type="checkbox"/> Do office work     | <input type="checkbox"/> Be a chef at an event   |
| <input type="checkbox"/> Do graphic design              | <input type="checkbox"/> Design sound       | <input type="checkbox"/> Design and sew costumes |
| <input type="checkbox"/> Other (please specify) _____   |   |  |

### MY SCHEDULE IS:

- Very flexible. I'm often available during weekdays.  
 Somewhat flexible. I can help on the occasional morning or afternoon during the week.  
 Not very flexible at all, but I've got some free time on evenings and weekends.

If you would like to mail this (and you're always welcome to enclose a tax-deductible contribution), you can send it to: **The 52nd Street Project**, 500 West 52nd St., New York, NY 10019. Or fax it to (212) 333-5598.



The One-on-Ones Program is made possible with public funds from The New York State Council on the Arts, a state agency; and the New York City Department of Cultural Affairs. The 52nd Street Project is a member of ART/NY and a participant in the New Generations Program, funded by Doris Duke Charitable Foundation/The Andrew W. Mellon Foundation and administered by Theatre Communications Group, the national organization for the American Theater.



**Don't Miss Our Upcoming Shows!**

# On the Other Hand: The Alternative Plays

Playback, October, 2003

First a kid writes a short play. Then, an adult writes an "answer" play using the same situations and characters as in the kid's play. Finally, the adult and the kid rehearse and perform both plays (as pals). Multiply this equation by seven and you've got an entire show. That's Playback, the most collaborative of all our shows. Don't miss it!

## A PIECE OF OUR MIND: Plays with Opinions



December, 2003

In September, 10 kids who are newcomers to the Project will begin a Playmaking class taught by Project Playmaking Director **Megan Sandberg-Zakian**. Come and see their final plays performed and directed by members of the New York Theater Community.

The 52nd Street Project is a non-profit organization that brings children from the Hell's Kitchen neighborhood together with professional theater artists to create original theater. **SECOND DATES WITH DESTINY** is a production of our One-on-One program, which is designed to give children the opportunity to go away for one-week stays in the country and enjoy the undivided attention of a professional theater artist who serves as friend, mentor, and collaborator. The Project is delighted to return to the Ensemble Studio Theatre, where we have been performing since our inception in 1981. We gratefully acknowledge the fact that if E.S.T. wasn't here, we'd be nowhere.

### The 52nd Street Project Board of Directors

Ben Barenholtz	Patricia M. Murphy, Esq.
Lisa Benavides	Carol Ochs
Rachel Chanoff	Willie Reale, <i>founder</i>
Cathy Dantchik	Gus Rogerson
Noël Dawkins	Shirley Rumierk, <i>alumni member</i>
Wendy Ettinger, <i>chair emeritus</i>	José Soto, Jr., <i>alumni member</i>
Louis P. Friedman	Pamala Tyson
Stephen Graham, <i>chair</i>	Laura Valeroso
Larry Jones	Wendy vanden Heuvel
James McDaniel	John A. Vassilaros
Frances McDormand	Jenny Wiener

### Special Thanks

Our Host Families –Gerry & Sam Gray; Anne & Colin McNay; Emily & John Morgan; Patty & David Strauss; Sidney Worthen & David Pearce; Beth McNay; Joe McNay; Joanna & Jack Nelson; Bob Krystofolski; and our headquarters host Peter, Helen & Christopher Randolph.

Sincere thanks to our super chef Christopher Randolph; Vanessa Valdes; Kurt Wootton; Robin Morse & Lucy Rogerson; Sophia Ochs MacVittie.

### In-Kind Contributions

Curt, Jamie, Suzanne, Carl, Tim, and everyone at the Ensemble Studio Theatre; Neil A. Mazzella and Hudson Scenic Studios; the Murphy Law Office; Stephanie Berger; Iris A. Brown; Ron Kastner and Capital Printing; Kenneth Cole Productions; Noggin; The Printing Store; Scholastic, Inc.; Diageo Chateau & Estate Wines; Entertainment Weekly; Alison Fraser; Newman's Own; Sesame Workshop; Wendy Stuhlberg; Tarte, Inc.; Terax America; John A. Vassilaros; Watkins, Inc.; Mayor's Office of Film & Television; Boylan's Bottling Co.; David Sneddon & Fairway Market; Andy Millon; Steve Olsen & The Westbank Cafe; Lorraine Tobias & Imaginary Studios; Jive Records, part of Zomba Music Group; and Prime Films.



## SECOND DATES WITH DESTINY - ACT 1

All original music composed by Patrick Barnes  
"Second Dates With Destiny Theme Song" lyrics by John Sheehy

### THE RIVALS

Written & Directed by Keira Naughton for Britney Castro, age 13

Descriptivus .....Britney Castro  
Metaphoricus .....Keira Naughton  
Commentator .....John Sheehy

"Nemesis" lyrics by Keira Naughton

### BREAD PUDDING

Written & Directed by Erica Schmidt for Mordecai Santiago, age 10

Albert .....Mordecai Santiago  
Elsa .....Erica Schmidt

"The Genius Song" lyrics by Erica Schmidt

### THE WRIGHT STUFF

Written & Directed by George Babiak for Paul Dixon, age 13

Orv .....Paul Dixon  
Will .....George Babiak  
Miss Amanda Honeywell .....Melissa Jones

"The Bike Shop Rag" lyrics by George Babiak

### MIMI MEETS HER MATCH

Written by Melissa Gawlowski & Directed by Saidah Arrika Ekulona  
for Octavia Rodriguez, age 12

Mimi Moore .....Octavia Rodriguez  
Dora Dogood .....Saidah Arrika Ekulona  
Edgar Edinhorpe .....Gus Rogerson  
Patrick .....Patrick Barnes

"You Can Do Anything" lyrics by Melissa Gawlowski

### VIKINGS RULE!

Written & Directed by Adam Felber for Jonathan Rosario, age 10

Torvald .....Jonathan Rosario  
Erich the Beige .....Adam Felber  
Warrior Horde .....The Crew

"We Viking!" lyrics by Adam Felber & Music by Holly Nadal

## SECOND DATES WITH DESTINY - ACT 2

### A VERY PRIVATE PRACTICE

Written & Directed by Clem Martini for Alex Tomas, age 12

Elwood .....Alex Tomas  
Juri .....Clem Martini

"Live Out My Dreams" lyrics by Clem Martini

### GET OVER THE HUMP

Written & Directed by Elizabeth Keiser for Steven Castellanos, age 11

Guru .....Steven Castellanos  
Sheri .....Elizabeth Keiser  
Commentator .....Patrick Barnes

"Mind Over Matter" and "It Isn't a Sin to Win" lyrics by Elizabeth Keiser

### GALILEO MEETS THE POPE

Written by Theresa Rebeck & Directed by Shirley A. Rumierk  
for Megan Cruz, age 12

Galileo .....Megan Cruz  
Pope .....Shirley A. Rumierk  
Underling .....John Sheehy

"The Earth May Rotate" lyrics by Theresa Rebeck

### TWO MEN IN A BOAT

Written & Directed by Matt Saldívar for Isayah Muller, age 11

Paolo de Gallo .....Isayah Muller  
Captain .....Matt Saldívar  
Tropical beauties .....Diana Rojas, Melissa Gawlowski

"Adventure!" lyrics by Matt Saldívar, Music by Patrick Barnes, Matt Saldívar,  
and Isayah Muller

### SPIKE AND THE STORYTELLER

Written by Michael Bernard & Directed by Michael Potts  
for Amanda Santos, age 12

Spike .....Amanda Santos  
The Storyteller .....Michael Potts  
Celestina .....Suzette Santana

"Tell Me A Story" lyrics by Michael Bernard

👉 **Intermission!** 👈

The 52nd Street Project gratefully acknowledges the support of the following foundations and corporations: Altria Employee Fund, Barker Welfare Foundation, The Barmley Foundation, Bloomberg, Blythmour Corporation, California Comedy, Capital Research Company, Carnegie Corporation of New York, Comedy Central, Davis Polk & Wardwell, Deutsche Bank of Americas Foundation, The Dramatists Guild Fund, Dramatists Play Service, Eleanor, Adam & Mel Dubin Foundation, Entertainment Weekly, The Horace W. Goldsmith Foundation, The William and Mary Greve Foundation, The Hennessy Foundation, Holland Lodge Foundation, Inc., Lloyds TSB Bank plc, Lucille Lortel Foundation, James A. Macdonald Foundation, Major League Baseball, Ann M. Martin Foundation, Mellon Bank, N.A., The New World Foundation, The New York Times Company Foundation, Newman's Own, Norcross Wildlife Foundation, Inc., Pfizer Foundation, Rytech Inc., St. James' Church, The Fan Fox & Leslie R. Samuels Foundation, Stranahan Foundation, Susquehanna Partners, G.P., Tiger Baron Foundation, John A. Vassilaros & Son, Inc., The Vervane Foundation, The Wiener Family Foundation, Zagat Survey, Felix Zarembo & Co. Inc. In addition the following individuals made gifts of over \$200 to The 52nd Street Project this year (list is current as of 10/10/03):

Jace Alexander & Maddie Corman  
 Lucie Amaz & Laurence Luckinbill  
 Dylan & Becky Baker  
 Ben Barenholtz  
 Jessica Bauman  
 Laurie Becker & Rick Sweren  
 Lisa Benavides & Tim Nelson  
 Vicky Bijur & Ed Levine  
 Lewis Black  
 Richard Blackstone & Yldeez Ylseksek  
 Tessa Blake  
 Buzz Bovsho  
 Bob Boyett  
 Becky Browder & Ted Neustadt  
 Susan Bruce & Peter Hedges  
 Alfred C. Cerullo III  
 Rachel Chanoff  
 Glenda Chesshir  
 Kirk & Katherine Holt Citron  
 Darah Cloud & Dave Owens  
 Ruth Cohen  
 Lieta Heslen-Cohen & Richard Cohn  
 Tricia Cooke & Ethan Coen  
 Hyla & Richard Crane  
 Margaret Crimmins  
 Billy Crudup & Mary Louise Parker  
 Tom Cruise  
 Catherine Curtin  
 Willem Dafoe & Liz Lecompte  
 John J. Dagenhard  
 Arthur Dantchik  
 Cathy Dantchik  
 Leslie Dantchik  
 Peter & Judith Dawkins  
 Georgia & William Delano  
 Jonathan Demme  
 Richard & Rebecca Dresser  
 Christopher & Karen Eddowes  
 Mario Egozi  
 David & Chrysti Eigenberg  
 Ned Eisenberg & Patricia Maguire

Nora Ephron  
 Wendy Ettinger & Derek McLane  
 Tom Feeney & Paul Parzuchowski  
 Peter Jay Fernandez & Denise Burse  
 Martin Fetner & William Coury  
 Angelina Fiordellisi  
 Alexa Fogel  
 Frank Frattaroli  
 Katherine Freedman  
 Naomi Freundlich & Charles Miles  
 Louis & Patrice Friedman  
 Janeane Garofalo  
 Rose Gasner & Larry Chertoff  
 Ileen Getz & Mark Grinnell  
 Paul & Liz Giamatti  
 Lloyd & Kilty Gilmour  
 Judy Goldman & Michael Pillinger  
 Tony Goldwyn & Jane Musky  
 Assembly Member Richard Gottfried  
 Stephen & Cathy Graham  
 Michael Greif & Jonathan Fried  
 Lisa Gugenheim  
 Mark & Valerie Hadjipateras  
 Jane & Jonathan Heine  
 Peter Herdrich & Karen Trott  
 William Holtzman & S. Sylvia Shepard  
 Katy Homans & Patterson Sims  
 Barbara Howard  
 Philip & Alexandra Howard  
 Dana Ivey  
 Mark Evan Jacobs  
 Sy Jacobs  
 Whitney Scott & Peter Jacobson  
 Andrea Johnson  
 Traci Paige Johnson & Robert Mowen  
 Larry & Mary Jones  
 Maurice Kanbar  
 Ronald Kastner & Vanessa Boeys  
 Seth & Beth Klarman  
 Judy Kuhn & David Schwab  
 Allan & Nanette Larson

Michael P. Lawrence  
 Mary Ann Lefort  
 Joshua Lewis & Sarah Kay  
 Anna Li  
 Linda Li  
 Adrienne Lobel & Mark Linn Baker  
 John Lyons  
 Grace Lyu-Volckhausen  
 Greg MacPherson & Jane Perlmutter  
 Nat Magee & Alison Fraser  
 Wendy Makkena & Bob Krakower  
 Doda Manalansan  
 Kay Matuschillat & Allan Arffa  
 Paul McCrane & Dana Kellin  
 Fran McDormand & Joel Coen  
 William Michael McMahon & Meg McMahon  
 Rick Meese & Dan Lori  
 Richard & Denise Menelly  
 Josie Merck & Jim Stevenson  
 Brian Mertes  
 Audrey & Danny Meyer  
 Suzen Murakoshi & Mark Temme  
 Patricia M. Murphy, Esq. & Adam Spilka  
 Don & Sara Nelson  
 Ruth Nelson  
 Mark Nesselson, M.D. & Elliott Rosenblum  
 Lori O'Connor  
 Kevin O'Rourke & Edith Thurber  
 Carol Ochs & Bruce MacVittie  
 Jacki Ochs & Jan Kroeze  
 Elizabeth Peters  
 Peter & Ana Rosa Phillips  
 Oliver Platt & Camilla Campbell Platt  
 Jeremy Posner  
 Dean & Leslie Potashner  
 Peter & Helen Randolph  
 Richard Rauchenberger  
 Willie Reale & Jenny Gersten  
 Theresa Rebeck & Jess Lynn  
 Herald & Linda Ritch

David & Anita Rogerson  
 Robin Morse & Gus Rogerson  
 Mark Saad  
 Steve Sabba  
 Laura Sametz & Anton Fig  
 Karin & Tom Schall  
 Leslie Schine & Nils Nielsen  
 Maury Schott  
 Ken & Mary Ann Schuster  
 Mitchell Semel & Colleen Carroll  
 Tom Shadyac  
 Richard Shaffer & Natakka Bukalo  
 Aaron & Elaine Shapiro  
 Bernice Baruch Shawl  
 Abby Jo Sigal & Matt Turner  
 Meg Simon  
 Talia Balsam & John Slattery  
 Abigail Rose Solomon  
 Jean Stein  
 David & Sara Stone  
 Abby Stranahan & Dave Ward  
 Susanna Styron & Darrell Larson  
 Brian Swardstrom & Bonnie Bernstein  
 Daniel Swee  
 Mariko Tada  
 John Turturro & Katherine Borowitz  
 Laura Valeroso & David Seidman  
 Wendy vanden Heuvel & Brad Coley  
 Ed Vassallo  
 John A. Vassallo  
 Mary Pat Walsh  
 Wendy Wasserstein  
 Sally & Lenny Weiss  
 Jane Bolster & Steve Wertimer  
 Carol Whitesides  
 Michael & Zena Wiener  
 Donald Windham  
 Joanne Woodward & Paul Newman  
 Bill Wrubel & Jennifer Crittenden  
 Jeffrey & Janine Yass  
 James & Mary Lin Yoshimura  
 William & Katherine Zarembo

The 52nd Street Project presents the 2003 Playback Show

# ON THE OTHER HAND

## THE ALTERNATIVE PLAYS

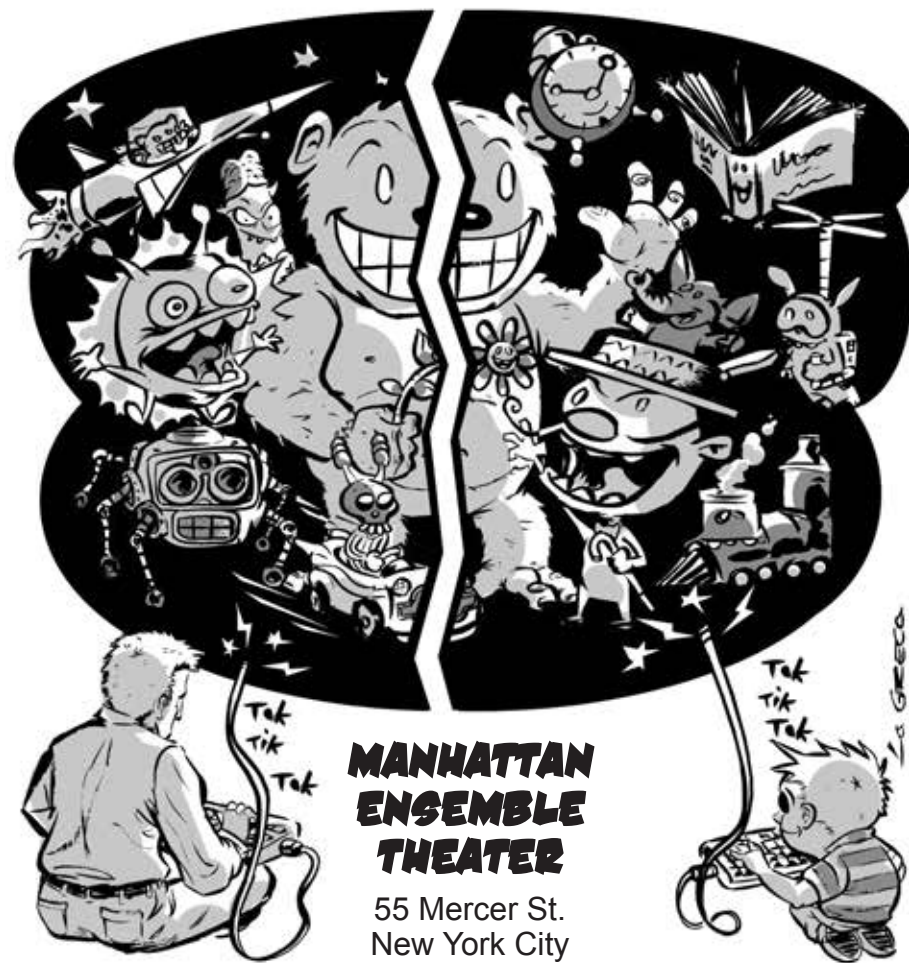

**MANHATTAN  
 ENSEMBLE  
 THEATER**

55 Mercer St.  
 New York City

Fri., Oct. 24 @ 7:30 p.m.,  
 Sat., Oct. 25 @ 7:30 p.m., Sun., Oct. 26 @ 3:00 p.m.

# ON THE OTHER HAND

THE ALTERNATIVE PLAYS

THE 2003  
PLAYBACK SHOW  
OCTOBER 24-26  
AT THE MET THEATER

### The 52nd Street Project Staff:

Gus Rogerson, Artistic Director  
 Carol Ochs, Executive Director  
 John Sheehy, Director of Development and Marketing  
 Megan Sandberg-Zakian, Associate Artistic Director  
 George "X-Acto" Babiak, Production Manager  
 Liz Bell, Director of Education  
 Diana Rojas, Executive Assistant  
 Chris Ceraso, Teen Dean  
 Iris A. Brown, Graphic Designer  
 Mayleen Cancel and Anju Andre-Bergmann, Receptionists  
 Intern: Danielle Hill



### Production Staff:

**Composer:** Loren Toolajian  
**Singing Coach:** Kari Riely  
**Set Designer:** Kevin Joseph Roach  
**Lighting Designer:** Greg MacPherson  
**Assistant Lighting Designer:**  
 Kelly Blackwell  
**Costume Designer:** Munee Hayes  
**Goddess of Sound:** Vanessa Valdes  
**Stage Manager:** Erica Schmidt  
**Slide Designers:**  
 George "Pollock" Babiak, Halina  
 "Picasso" Newberry, Henri "Matisse"  
 Bodo, Roy "Warhol" Mills, Gina "van  
 Gogh" Cline.  
**"Other Hand" Illustration:**  
 Charlie LaGreca  
**Prop Design Team:**  
 Justin Aponte, George Babiak,

Heather Carnduff, Nikki Fargardo,  
 Esther Geller, Danielle Hill, Karen  
 Munkel, Adam Robinson, Lee Rosen,  
 John Sheehy, Michael Velez  
**Furniture Crew:**  
 Erik Bowie, Ariana Casablanca  
**Prop Crew:**  
 Solangee Acosta, Danielle Hill  
**Load-in and Light Hang Crew:**  
 Mona Arriola, Kelly Blackwell,  
 Lee Briggs, Nedra Gallegos, Anne  
 O'Sullivan, Christopher Randolph,  
 Tom Schall, Jolie Tong  
**House Managers:**  
 Karin Schall, Beth Emelson,  
 Liz Flahive  
**Chefs:**  
 John Sheehy, Liz Bell



The Playback Program is made possible with public funds from The New York State Council on the Arts, a state agency. The 52nd Street Project is a member of Art/NY and a participant in the New Generations Program, funded by Doris Duke Charitable Foundation/The Andrew W. Mellon Foundation and administered by Theatre Communications Group, the national organization for the American Theater.



# COOL STUFF ON SALE!

Flyer Bars .....\$2.00, \$1.50 & \$1.00

*Shel Silverstein's "Fivey and Twoey" logo gear:*

Project T-shirts .....\$12.00  
 Project long sleeve t-Shirts .....\$15.00  
 Project Caps .....\$15.00  
 Project Mugs .....\$5.00  
 Project Pencil 3-pack .....\$1.00

Thank you for coming to **ON THE OTHER HAND...** If you are not on our mailing list (or if your address has changed), please fill out this form and give it to us on your way out or mail it to the address below. We would also like to know if you are interested in becoming a volunteer. We need help in **all areas**, so be sure to fill out the entire form.

### PLEASE ADD ME TO YOUR MAILING LIST:

10/03

NAME: \_\_\_\_\_

ADDRESS: \_\_\_\_\_

\_\_\_\_\_ ZIP \_\_\_\_\_

HOME PHONE: \_\_\_\_\_

DAYTIME PHONE: \_\_\_\_\_

E-MAIL ADDRESS: \_\_\_\_\_

MY OCCUPATION: \_\_\_\_\_

MY HOBBIES: \_\_\_\_\_

### YES, I WOULD LIKE TO BE OF HELP. I CAN:

- |   |   |  |
|---|---|--|
| <input type="checkbox"/> Help load in and out for shows | <input type="checkbox"/> Draw and/or paint  | <input type="checkbox"/> Help kids with homework |
| <input type="checkbox"/> Hang lights                    | <input type="checkbox"/> Help with mailings | <input type="checkbox"/> Teach kids a skill      |
| <input type="checkbox"/> Work on a backstage crew       | <input type="checkbox"/> Do office work     | <input type="checkbox"/> Be a chef at an event   |
| <input type="checkbox"/> Do graphic design              | <input type="checkbox"/> Design sound       | <input type="checkbox"/> Design and sew costumes |
| <input type="checkbox"/> Other (please specify) _____   |   |  |

### MY SCHEDULE IS:

- Very flexible. I'm often available during weekdays.  
 Somewhat flexible. I can help on the occasional morning or afternoon during the week.  
 Not very flexible at all, but I've got some free time on evenings and weekends.

If you would like to mail this (and you're always welcome to enclose a tax-deductible contribution), you can send it to: **The 52nd Street Project**, 500 West 52nd St., New York, NY 10019. Or fax it to (212) 333-5598.



## Don't Miss Our Upcoming Shows!

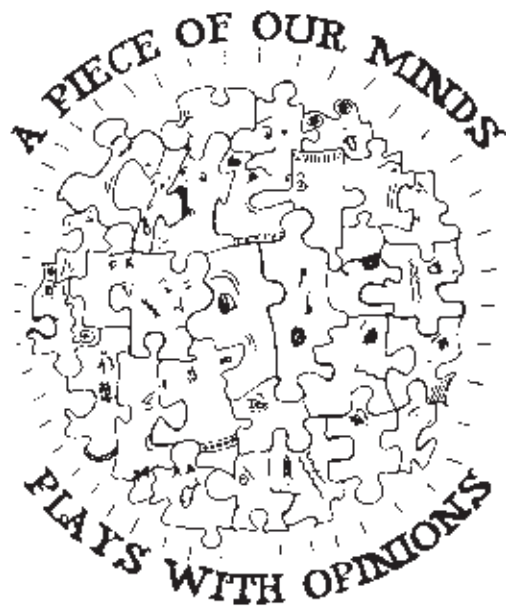

### December 12-14 Playwright's Horizons Upstairs Theater

In September, 10 kids brand-new to the Project began a Playmaking class taught by Playmaking Director Megan Sandberg-Zakian.

Come and see their final plays performed by adult professional actors.

**"IF AT FIRST  
YOU DON'T  
SUCCEED..."**

**PLAYS THAT TRY AGAIN  
Playback, Round II  
February, 2004**

We're doing it again, but with new kids, new adults, new plays, and a new theater...not to mention a new theme. Come see it!



The 52nd Street Project is a non-profit organization that brings children from the Hell's Kitchen neighborhood together with professional theater artists to create original theater. **ON THE OTHER HAND** is a production of our **Playback** program, in which kid actor/playwrights write plays which are then "answered" by adult actor/playwright partners who write their own plays. We then took the whole menagerie up to the idyllic hamlet of Franklin, NY over the Columbus Day weekend to rehearse the shows. In the final production, which you see here tonight, the partners perform both plays back-to-back. All of the kids involved are veterans of the Playmaking classes which were adapted for the Project by Daniel Judah Sklar from his book *Playmaking: Children Writing and Performing Their Own Plays*.

### The 52nd Street Project Board of Directors

Ben Barenholtz  
Lisa Benavides  
Rachel Chanoff  
Cathy Dantchik  
Noël Dawkins  
Wendy Ettinger,  
*chair emeritus*  
Louis P. Friedman  
Stephen Graham, *chair*  
Larry Jones  
James McDaniel  
Frances McDormand  
Patricia M. Murphy, Esq.

Carol Ochs  
Willie Reale,  
*founder*  
Gus Rogerson  
Shirley Rumierk,  
*alumni member*  
José Soto, Jr.,  
*alumni member*  
Pamala Tyson  
Laura Valeroso  
Wendy vanden Heuvel  
John A. Vassilaros  
Jenny Wiener

### Special Thanks

We're extremely grateful to **Gene, Carol, and Carmela Marner; David Bridel, Wendy, Tom and Erna Morgan**, and all the folks in Franklin, NY for being such gracious hosts on the weekend away. **Ed Vassallo** gets a special foam-core Medal of Honor for arranging the entire expedition. Thanks, Ed.

### In-Kind Contributions

We are also indebted to Neil A. Mazzella and Hudson Scenic Studios; the Murphy Law Office; Iris A. Brown; Ron Kastner and Capital Printing; Kenneth Cole Productions; Noggin; Scholastic, Inc.; Diageo Chateau & Estate Wines; Entertainment Weekly; Alison Fraser; Newman's Own; Sesame Workshop; Wendy Stuhlberg; Tarte, Inc.; Terax America; John A. Vassilaros; Watkins, Inc.; Mayor's Office of Film & Television; Boylan's Bottling Co.; David Sneddon & Fairway Market; Steve Olsen & The Westbank Cafe; Lorraine Tobias & Imaginary Studios; Jive Records, part of Zomba Music Group; and Prime Films.

## ON THE OTHER HAND - ACT I

All original music composed by Loren Toolajian

### Like Mother, Like Daughter

By Jazzy Hernandez, age 12. Dramaturg/Director: Kate Marks

### Like Daughter, Like Mother

 Written and directed by Kate Marks

Monica/Missy .....Jazzy Hernandez  
Ashley .....Kate Marks  
Teen-age friends .....Erik Bowie, George Babiak  
“Missy and Ashley’s Song” lyrics by Kate Marks

### The Mistorie

By John Cuevas, age 13. Dramaturg/Director: Megan Sandberg-Zakian

### Behind The Mistorie

Written and Directed by Megan Sandberg-Zakian

Mystoman .....John Cuevas  
Mermaid Mary .....Megan Sandberg-Zakian  
Teller .....Ariana Casablanca  
Bank Customer .....Solangee Acosta  
People in line .....Crew  
Policeman .....George Babiak

“Now I am Happy” lyrics by John Cuevas, “Didn’t You Know?” lyrics by Megan Sandberg-Zakian

### Just Put It Like This

By Johanna Vidal, age 13. Dramaturg/Director: Jolie Tong

### Lost and Found

 Written and directed by Jolie Tong

Denise/Ruth .....Johanna Vidal  
Livia .....Diana Rojas  
The kid .....Erik Bowie

“Denise’s Song” lyrics by Johanna Vidal, “Why Can’t This Be Easy?” lyrics by Jolie Tong

### The House

By Aladino Olivares, age 12. Dramaturg/Director: Reg Flowers

### The Money Trap

 Written and Directed by Reg Flowers

Jason .....Aladino Olivares  
Sergio .....Reg Flowers  
The Narrator/Bright Light .....George Babiak

“Change Can Take Some Time” lyrics by Reg Flowers

☞ **Intermission!** ☞

## ON THE OTHER HAND - ACT II

### The Swordsmen

By Alex Kehr, age 12. Dramaturg/Director: Tom Schall

### The Unkindest Cut

 Written and directed by Tom Schall

Josh Perez .....Alex Kehr  
Max Perez .....Tom Schall

### Family Issues

By Katherine Acosta, age 13. Dramaturg/Director: Gus Rogerson

### Sweet Sixteen

Written and directed by Gus Rogerson

Maria Smith .....Katherine Acosta  
Junior Smith .....Gus Rogerson  
Mother’s voice .....Diana Rojas  
Officer One .....Erik Bowie  
Officer Two .....George Babiak

“Family Issues and Sweet Sixteen: The Songs”: lyrics by Gus Rogerson.

### The Relationship Between Two Friends

By Kayelani Silva, age 12. Dramaturg/Director: Becky White

### Home is Where You Make It

Written and directed by Becky White

Angel Smith/Sploradora .....Kayelani Silva  
Esperanza/Skwawk .....Becky White  
Angel’s Mom .....Diana Rojas  
Angel’s Dad/Sergeant Supitchoo .....George Babiak

“Yippee” lyrics by Kayelani Silva, “Home is Where You Make It” lyrics by Becky White



The 52nd Street Project gratefully acknowledges the support of the following foundations and corporations: Altria Employee Fund, Barker Welfare Foundation, The Barnsley Foundation, Bloomberg, Blythmour Corporation, California Comedy, Capital Research Company, Carnegie Corporation of New York, Comedy Central, Davis Polk & Wardwell, Deutsche Bank of Americas Foundation, The Dramatists Guild Fund, Dramatists Play Service, Eleanor, Adam & Mel Dubin Foundation, Entertainment Weekly, The Horace W. Goldsmith Foundation, The William and Mary Greve Foundation, The Hennessy Foundation, Holland Lodge Foundation, Inc., Lloyds TSB Bank plc, Lucille Lortel Foundation, James A. Macdonald Foundation, Major League Baseball, Ann M. Martin Foundation, Mellon Bank, N.A., The New World Foundation, The New York Times Company Foundation, Newman's Own, Norcross Wildlife Foundation, Inc., Pfizer Foundation, Rytech Inc., St. James' Church, The Fan Fox & Leslie R. Samuels Foundation, Stranahan Foundation, Susquehanna Partners, G.P., Tiger Baron Foundation, John A. Vassilaros & Son, Inc., The Vervane Foundation, The Wiener Family Foundation, Zagat Survey, Felix Zaremba & Co. Inc. In addition the following individuals made gifts of over \$200 to The 52nd Street Project this year (list is current as of 10/10/03):

Jace Alexander & Maddie Corman  
 Lucie Amaz & Laurence Luckinbill  
 Dylan & Becky Baker  
 Ben Barenholtz  
 Jessica Bauman  
 Laurie Becker & Rick Sweren  
 Lisa Benavides & Tim Nelson  
 Vicky Bijur & Ed Levine  
 Lewis Black  
 Richard Blackstone & Yldeez Yulksek  
 Tessa Blake  
 Buzz Bovsho  
 Bob Boyett  
 Becky Browder & Ted Neustadt  
 Susan Bruce & Peter Hedges  
 Alfred C. Cerullo III  
 Rachel Chanoff  
 Glenda Chesshir  
 Kirk & Katherine Holt Citron  
 Darah Cloud & Dave Owens  
 Ruth Cohen  
 Lieta Heslen-Cohen & Richard Cohn  
 Tricia Cooke & Ethan Coen  
 Hyla & Richard Crane  
 Margaret Crimmins  
 Billy Crudup & Mary Louise Parker  
 Tom Cruise  
 Catherine Curtin  
 Willem Dafoe & Liz Lecompte  
 John J. Dagenhard  
 Arthur Dantchik  
 Cathy Dantchik  
 Leslie Dantchik  
 Peter & Judith Dawkins  
 Georgia & William Delano  
 Jonathan Demme  
 Richard & Rebecca Dresser  
 Christopher & Karen Eddowes  
 Mario Egozi  
 David & Chrysti Eigenberg  
 Ned Eisenberg & Patricia Maguire

Nora Ephron  
 Wendy Ettinger & Derek McLane  
 Tom Feeney & Paul Parzuchowski  
 Peter Jay Fernandez & Denise Burse  
 Martin Fetner & William Coury  
 Angelina Fiordellisi  
 Alexa Fogel  
 Frank Frattaroli  
 Katherine Freedman  
 Naomis Freundlich & Charles Miles  
 Louis & Patrice Friedman  
 Janeane Garofalo  
 Rose Gasner & Larry Chertoff  
 Ileen Getz & Mark Grinnell  
 Paul & Liz Giamatti  
 Lloyd & Kilty Gilmour  
 Judy Goldman & Michael Pillinger  
 Tony Goldwyn & Jane Musky  
 Assembly Member Richard Gottfried  
 Stephen & Cathy Graham  
 Michael Greif & Jonathan Fried  
 Lisa Gugenheim  
 Mark & Valerie Hadjipateras  
 Jane & Jonathan Heine  
 Peter Herdrich & Karen Trott  
 William Holtzman & S. Sylvia Shepard  
 Katy Homans & Patterson Sims  
 Barbara Howard  
 Philip & Alexandra Howard  
 Dana Ivey  
 Mark Evan Jacobs  
 Sy Jacobs  
 Whitney Scott & Peter Jacobson  
 Andrea Johnson  
 Traci Paige Johnson & Robert Mowen  
 Larry & Mary Jones  
 Maurice Kanbar  
 Ronald Kastner & Vanessa Boeye  
 Seth & Beth Klarman  
 Judy Kuhn & David Schwab  
 Allan & Nanette Larson

Michael P. Lawrence  
 Mary Ann Lefort  
 Joshua Lewis & Sarah Kay  
 Anna Li  
 Linda Li  
 Adrienne Lobel & Mark Linn Baker  
 John Lyons  
 Grace Lyu-Volckhausen  
 Greg MacPherson & Jane Perlmutter  
 Nat Magee & Alison Fraser  
 Wendy Makkena & Bob Krakower  
 Doda Manalansan  
 Kay Matuschullat & Allan Arffa  
 Paul McCrane & Dana Kellin  
 Fran McDormand & Joel Coen  
 William Michael McMahon & Meg McMahon  
 Rick Meese & Dan Lori  
 Richard & Denise Menelly  
 Josie Merck & Jim Stevenson  
 Brian Mertes  
 Audrey & Danny Meyer  
 Suzen Murakoshi & Mark Temme  
 Patricia M. Murphy, Esq. & Adam Spilka  
 Don & Sara Nelson  
 Ruth Nelson  
 Mark Nesselson, M.D. & Elliott Rosenblum  
 Lori O'Connor  
 Kevin O'Rourke & Edith Thurber  
 Carol Ochs & Bruce MacVittie  
 Jacki Ochs & Jan Kroeze  
 Elizabeth Peters  
 Peter & Ana Rosa Phillips  
 Oliver Platt & Camilla Campbell Platt  
 Jeremy Posner  
 Dean & Leslie Potashner  
 Peter & Helen Randolph  
 Richard Rauchenberger  
 Willie Reale & Jenny Gersten  
 Theresa Rebeck & Jess Lynn  
 Herald & Linda Ritch

David & Anita Rogerson  
 Robin Morse & Gus Rogerson  
 Mark Saad  
 Steve Sabba  
 Laura Sametz & Anton Fig  
 Karin & Tom Schall  
 Leslie Schine & Nils Nielsen  
 Maury Schott  
 Ken & Mary Ann Schuster  
 Mitchell Semel & Colleen Carroll  
 Tom Shadyac  
 Richard Shaffer & Nataalka Bukalo  
 Aaron & Elaine Shapiro  
 Bernice Baruch Shawl  
 Abby Jo Sigal & Matt Turner  
 Meg Simon  
 Talia Balsam & John Slattery  
 Abigail Rose Solomon  
 Jean Stein  
 David & Sara Stone  
 Abby Stranahan & Dave Ward  
 Susanna Styron & Darrell Larson  
 Brian Swardstrom & Bonnie Bernstein  
 Daniel Swee  
 Mariko Tada  
 John Turturro & Katherine Borowitz  
 Laura Valeroso & David Seidman  
 Wendy vanden Heuvel & Brad Coley  
 Ed Vassallo  
 John A. Vassallo  
 Mary Pat Walsh  
 Wendy Wasserstein  
 Sally & Lenny Weiss  
 Jane Bolster & Steve Wertimer  
 Carol Whitesides  
 Michael & Zena Wiener  
 Donald Windham  
 Joanne Woodward & Paul Newman  
 Bill Wrubel & Jennifer Crittenden  
 Jeffrey & Janine Yass  
 James & Mary Lin Yoshimura  
 William & Katherine Zaremba

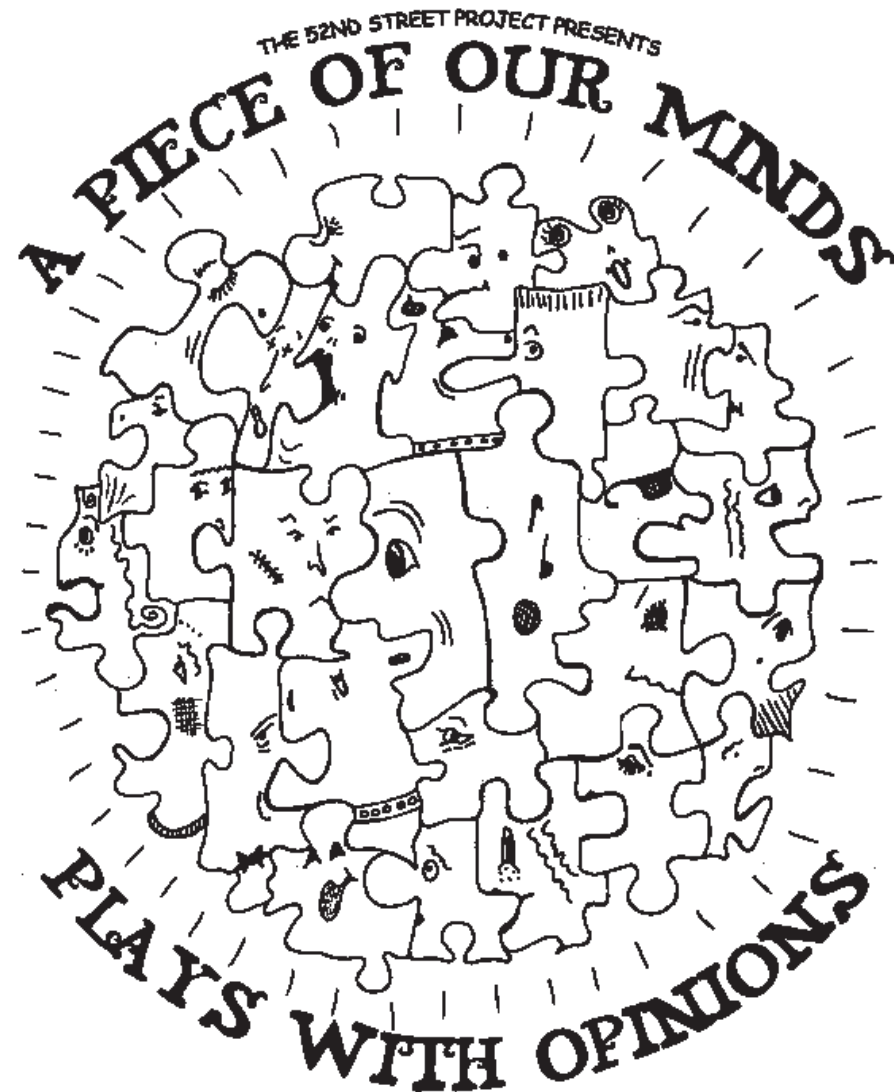

*The Fall 2003 Playmaking Series*

Fri., Dec. 12 at 7:30 p.m.,  
 Sat., Dec. 13 at 3:00 p.m. and 7:30 p.m.  
 and Sun., Dec. 14 at 3:00 p.m.

*The Peter Jay Sharp Theater at Playwrights Horizons*  
 416 W. 42nd St.

# A PIECE OF OUR MINDS

The Fall 2003 Playmaking Plays - Dec. 12-14,  
The Peter Jay Sharp Theater at Playwrights Horizons

## The 52nd Street Project Staff:

Gus Rogerson, Artistic Director  
Carol Ochs, Executive Director  
John Sheehy, Director of Development and Marketing  
Megan Sandberg-Zakian, Associate Artistic Director  
George "X-Acto" Babiak, Production Manager  
Liz Bell, Director of Education  
Diana Rojas, Executive Assistant  
Chris Ceraso, Teen Dean  
Iris A. Brown, Graphic Designer  
Anju Andre-Bergmann and Mayleen Cancel, Receptionists

## Production Staff

**Composer:** Patrick Barnes  
**Set Designer:** Kevin Joseph Roach  
**Lighting Designers:**  
Greg MacPherson & Kelly Blackwell

## Costume Designer:

Elizabeth Bourgeois

## Sound Designer:

Maury Schott

## Stage Manager:

Katie Ahern

## Slide Designers:

George Babiak, Chris Bonanos,  
Renato Castilho, Vanessa Enriquez,  
Katherine Lumb, Mike Sell,  
John Steward, Alberta Testanero,  
Iwona Waluk

## "POOM" Illustration:

Esther Geller

## Prop Design Team:

George Babiak, Nicole Fargardo,  
Gardi and Fiona from South Africa,  
Karen Munkel, Lee Rosen, Kevin  
Ryder, Amy Yen

## Furniture Crew:

Ephraim Lopez  
and Christopher Ramirez

## Prop Crew:

Michael Coglán and Nicole Fargardo

## Load-in and Light Hang Crew:

Kelly Blackwell, Giselda Beaudin,  
Lee Briggs, Melissa Jones,  
Karen Munkel, Christopher  
Randolph, Betsy Rhodes,  
Tom Schall

## Playmaking Class Volunteers:

Jed Clarke, Danielle Hill, Nathan  
Lang, Moira MacDonald, Deirdre  
O'Connor, Nicole Phillips

## House Managers:

Karin Schall, Mary Pat Walsh,  
Liz Bell

## Hosts:

Eric Karpeles and Mike Sell

## Master Chef:

Eric Karpeles



The Playmaking Program is made possible with public funds from The New York State Council on the Arts, a state agency. The 52nd Street Project is a member of Art/NY and a participant in the New Generations Program, funded by Doris Duke Charitable Foundation/The Andrew W. Mellon Foundation and administered by Theatre Communications Group, the national organization for the American Theater.



# COOL STUFF ON SALE!



Flyer Bars .....\$2.00, \$1.50 & \$1.00

*Shel Silverstein's "Fivey and Twoey" logo gear:*

Project sweatshirts .....\$20.00

Project long sleeve t-Shirts .....\$15.00

Project Caps .....\$15.00

Project Mugs .....\$5.00

Project Pencil 3-pack .....\$1.00

"Sweet Appreciation" CD .....\$25.00

Thank you for coming to **A PIECE OF OUR MINDS**. If you are not on our mailing list (or if your address has changed), please fill out this form and give it to us on your way out or mail it to the address below. We would also like to know if you are interested in becoming a volunteer. We need help in **all areas**, so be sure to fill out the entire form.



## PLEASE ADD ME TO YOUR MAILING LIST:

12/03

NAME: \_\_\_\_\_

ADDRESS: \_\_\_\_\_

ZIP \_\_\_\_\_

HOME PHONE: \_\_\_\_\_

DAYTIME PHONE: \_\_\_\_\_

E-MAIL ADDRESS: \_\_\_\_\_

MY OCCUPATION: \_\_\_\_\_

MY HOBBIES: \_\_\_\_\_

## YES, I WOULD LIKE TO BE OF HELP. I CAN:

- |   |   |  |
|---|---|--|
| <input type="checkbox"/> Help load in and out for shows | <input type="checkbox"/> Draw and/or paint  | <input type="checkbox"/> Help kids with homework |
| <input type="checkbox"/> Hang lights                    | <input type="checkbox"/> Help with mailings | <input type="checkbox"/> Teach kids a skill      |
| <input type="checkbox"/> Work on a backstage crew       | <input type="checkbox"/> Do office work     | <input type="checkbox"/> Be a chef at an event   |
| <input type="checkbox"/> Do graphic design              | <input type="checkbox"/> Design sound       | <input type="checkbox"/> Design and sew costumes |
| <input type="checkbox"/> Other (please specify) _____   |   |  |

## MY SCHEDULE IS:

- Very flexible. I'm often available during weekdays.  
 Somewhat flexible. I can help on the occasional morning or afternoon during the week.  
 Not very flexible at all, but I've got some free time on evenings and weekends.

If you would like to mail this (and you're always welcome to enclose a tax-deductible contribution), you can send it to: **The 52nd Street Project**, 500 West 52nd St., New York, NY 10019. Or fax it to (212) 333-5598.

## Don't Miss Our Upcoming Shows!

**"IF AT FIRST  
YOU DON'T  
SUCCEED..."**



**PLAYS THAT TRY AGAIN**

**Playback, Round II  
February, 2004**

We're doing it again, but with new kids, new adults, new plays, and a new theater...not to mention a new theme. Come see it!

## THE WINTER EDITION...



**APRIL, 2004  
AT A THEATER  
TO BE ANNOUNCED.**

If you're enjoying the show tonight, you'll want to take in another set of shows by our *next* batch of Project newcomers! Call 642-5052 for reservations.

The 52nd Street Project is a non-profit organization that brings children from the Hell's Kitchen neighborhood together with professional theater artists to create original theater. **A PIECE OF OUR MINDS** is a production of our Playmaking program. Young people participate in a nine-week playwriting course taught by Megan Sandberg-Zakian and adapted for the Project by Daniel Judah Sklar from his book *Playmaking: Children Writing and Performing Their Own Plays*. At the end of the course, each child is given two actors, a theme, and a dramaturg/director who guides him or her through the writing of a play during a weekend retreat in the country (Tyler Hill, Pennsylvania, for this show). Tonight's performance is the end result.

### The 52nd Street Project Board of Directors

Ben Barenholtz

Lisa Benavides

Rachel Chanoff

Cathy Dantchik

Noël Dawkins

Wendy Ettinger,

*chair emeritus*

Louis P. Friedman

Stephen Graham, *chair*

Larry Jones

James McDaniel

Frances McDormand

Patricia M. Murphy, Esq.

Carol Ochs

Willie Reale,

*founder*

Gus Rogerson

Shirley Rumierk,

*alumni member*

José Soto, Jr.,

*alumni member*

Pamala Tyson

Laura Valeroso

Wendy vanden Heuvel

John A. Vassilaros

Jenny Wiener

### Special Thanks

We're extremely grateful to **Eric Karpeles** and **Mike Sell**, who graciously allowed us to use their beautiful home in Pennsylvania as our base of operations for the writer's retreat. Thanks also to our terrific host families, the **Cobbs**, the **Pursches**, the **Rutledges**, **Sohail Raikhy**, **Joan Henry**, the **Heyns**, **Katy Homans** and **Patterson Sims**, and **Dylan** and **Becky Baker**. We must also express our gratitude to **Tim Sanford**, **Leslie Marcus**, **William Russo**, **Christopher Boll**, **Doug Filomena**, and **Mike Rafael** and all the other folks at Playwrights Horizons for the use of their beautiful theater.

### In-Kind Contributions

We are also indebted to **Neil A. Mazzella** and **Hudson Scenic Studios**; the **Murphy Law Office**; **Iris A. Brown**; **Ron Kastner** and **Capital Printing**; **Kenneth Cole Productions**; **Noggin**; **Scholastic, Inc.**; **Diageo Chateau & Estate Wines**; **Entertainment Weekly**; **Alison Fraser**; **Newman's Own**; **Sesame Workshop**; **Wendy Stuhlberg**; **Tarte, Inc.**; **Terax America**; **John A. Vassilaros**; **Watkins, Inc.**; **Mayor's Office of Film & Television**; **Boylan's Bottling Co.**; **David Sneddon & Fairway Market**; **Steve Olsen & The Westbank Cafe**; **Lorraine Tobias & Imaginary Studios**; **Jive Records**, part of **Zomba Music Group**; and **Prime Films**.



All original music composed by Patrick Barnes

**War Between Love**

By Matthew Ortiz, age 10. Dramaturg/Director: Lee Wilkof

Arthur .....Walker Jones  
 Erika .....Liza Colon-Zayas  
*“He Fights On”* and *“Fight Together”* lyrics by Matthew Ortiz

**Pro Skateboarders**

By Jason Peterson Ridge, age 10.  
 Dramaturg/Director: Jonathan Bernstein

Lob .....Nathan Lang  
 Nob .....Erik Bowie  
 The Fans .....The Crew  
 Voice of the Skateboard .....Jonathan Bernstein

**The Mafia Tragedy**

by A.J. Welsh, age 10. Dramaturg/Director: John Sheehy

Sunny Ferguson .....Jed Clarke  
 Zoe Ramirez .....Martha Plimpton  
 The Boss .....George Babiak

**How Did a Princess Turn Into a Cat?**

by Luz Maldonado, age 10. Dramaturg/Director: Liliana Amador

Princess Fiona .....Lenore Pemberton  
 Little Princess .....Caroline Clay  
*“Fiona’s Song”* lyrics by Luz Maldonado

**The Big Argument**

by Carla Olivia, age 9. Dramaturg/Director: Liza Steinberg

Shanelle .....Ellen Foley  
 Mabel .....Kathy Hiler  
*“I’m Sorry”* lyrics by Carla Olivia



**The Dancing Fool**

by Stephanie Vamvoukakis, age 9.  
 Dramaturg/Director: Madeleine George

Jeanette .....Joselin Reyes  
 Jennifer .....Wendy vanden Heuvel  
 Clubbers .....The Crew  
*“Why Can’t I”* and *“Now I Can”* lyrics by Stephanie Vamvoukakis

**The Horror**

by Junior Chatman, age 11. Dramaturg/Director: Danyon Davis

Timmy .....Paco Tolson  
 Jimmy .....Peter Appel  
 Computer Associate .....Christopher Ramirez

**Love Birds**

by Katherine Alvarez, age 11. Dramaturg/Director: Rick Meese

Epiphany Jones .....Mercedes Herrero  
 Sam Smith .....Christopher Randolph

**The Legend of Dragons and Dinosaurs**

by George Zapata, age 9. Dramaturg/Director: Jeanne Simpson

Thunder .....Thom Sesma  
 Lightning .....Shona Tucker

**The Deadline**

by Jennifer Ramirez, age 10. Dramaturg/Director: Jennifer Ostrega

Kevin .....Felix Solis  
 Carlos .....Stephen Barker Turner  
*“Friends Forever”* lyrics by Jennifer Ramirez.



*Happy  
 Holidays  
 to all  
 Projectiles!*

The 52nd Street Project gratefully acknowledges the support of the following foundations and corporations: Altria Employee Fund, Barker Welfare Foundation, The Barmley Foundation, Bloomberg, Blythmour Corporation, California Comedy, Capital Research Company, Carnegie Corporation of New York, Comedy Central, Davis Polk & Wardwell, Deutsche Bank of Americas Foundation, The Dramatists Guild Fund, Dramatists Play Service, Eleanor, Adam & Mel Dubin Foundation, Entertainment Weekly, The Horace W. Goldsmith Foundation, The William and Mary Greve Foundation, The Hennessy Foundation, Holland Lodge Foundation, Inc., Lloyds TSB Bank plc, Lucille Lortel Foundation, James A. Macdonald Foundation, Major League Baseball, Ann M. Martin Foundation, Mellon Bank, N.A., The New World Foundation, The New York Times Company Foundation, Newman's Own, Norcross Wildlife Foundation, Inc., Pfizer Foundation, Rytech Inc., St. James' Church, The Fan Fox & Leslie R. Samuels Foundation, Stranahan Foundation, Susquehanna Partners, G.P., Tiger Baron Foundation, John A. Vassilaros & Son, Inc., The Vervane Foundation, The Wiener Family Foundation, Zagat Survey, Felix Zaremby & Co. Inc. In addition the following individuals made gifts of over \$200 to The 52nd Street Project this year (list is current as of 10/10/03):

Jace Alexander & Maddie Corman  
 Lucie Amaz & Laurence Luckinbill  
 Dylan & Becky Baker  
 Ben Barenholtz  
 Jessica Bauman  
 Laurie Becker & Rick Sweren  
 Lisa Benavides & Tim Nelson  
 Vicky Bijur & Ed Levine  
 Lewis Black  
 Richard Blackstone & Yldeez Yuksek  
 Tessa Blake  
 Buzz Boyshow  
 Bob Boyett  
 Becky Browder & Ted Neustadt  
 Susan Bruce & Peter Hedges  
 Alfred C. Cerullo III  
 Rachel Chanoff  
 Glenda Chesshir  
 Kirk & Katherine Holt Citron  
 Darah Cloud & Dave Owens  
 Ruth Cohen  
 Lieta Heslen-Cohen & Richard Cohn  
 Tricia Cooke & Ethan Coen  
 Hyla & Richard Crane  
 Margaret Crimmins  
 Billy Crudup & Mary Louise Parker  
 Tom Cruise  
 Catherine Curtin  
 Willem Dafoe & Liz Lecompte  
 John J. Dagenhard  
 Arthur Dantchik  
 Cathy Dantchik  
 Leslie Dantchik  
 Peter & Judith Dawkins  
 Georgia & William Delano  
 Jonathan Demme  
 Richard & Rebecca Dresser  
 Christopher & Karen Eddowes  
 Mario Egozi  
 David & Chrysti Eigenberg  
 Ned Eisenberg & Patricia Maguire

Nora Ephron  
 Wendy Ettinger & Derek McLane  
 Tom Feeney & Paul Parzuchowski  
 Peter Jay Fernandez & Denise Burse  
 Martin Fetner & William Coury  
 Angelina Fiordellisi  
 Alexa Fogel  
 Frank Frattaroli  
 Katherine Freedman  
 Naomi Freundlich & Charles Miles  
 Louis & Patrice Friedman  
 Janeane Garofalo  
 Rose Gasner & Larry Chertoff  
 Ileen Getz & Mark Grinnell  
 Paul & Liz Giamatti  
 Lloyd & Kilty Gilmour  
 Judy Goldman & Michael Pillinger  
 Tony Goldwyn & Jane Musky  
 Assembly Member Richard Gottfried  
 Stephen & Cathy Graham  
 Michael Greif & Jonathan Fried  
 Lisa Gugenheim  
 Mark & Valerie Hadjipateras  
 Jane & Jonathan Heine  
 Peter Herdrich & Karen Trott  
 William Holtzman & S. Sylvia Shepard  
 Katy Homans & Patterson Sims  
 Barbara Howard  
 Philip & Alexandra Howard  
 Dana Ivey  
 Mark Evan Jacobs  
 Sy Jacobs  
 Whitney Scott & Peter Jacobson  
 Andrea Johnson  
 Traci Paige Johnson & Robert Mowen  
 Larry & Mary Jones  
 Maurice Kanbar  
 Ronald Kastner & Vanessa Boeye  
 Seth & Beth Klarman  
 Judy Kuhn & David Schwab  
 Allan & Nanette Larson

Michael P. Lawrence  
 Mary Ann Lefort  
 Joshua Lewis & Sarah Kay  
 Anna Li  
 Linda Li  
 Adrienne Lobel & Mark Linn Baker  
 John Lyons  
 Grace Lyu-Volckhausen  
 Greg MacPherson & Jane Perlmutter  
 Nat Magee & Alison Fraser  
 Wendy Makkena & Bob Krakower  
 Doda Manalansan  
 Kay Matuschullat & Allan Arffa  
 Paul McCrane & Dana Kellin  
 Fran McDormand & Joel Coen  
 William Michael McMahon & Meg McMahon  
 Rick Meese & Dan Lori  
 Richard & Denise Menelly  
 Josie Merck & Jim Stevenson  
 Brian Mertes  
 Audrey & Danny Meyer  
 Suzen Murakoshi & Mark Temme  
 Patricia M. Murphy, Esq. & Adam Spilka  
 Don & Sara Nelson  
 Ruth Nelson  
 Mark Nesselson, M.D. & Elliott Rosenblum  
 Lori O'Connor  
 Kevin O'Rourke & Edith Thurber  
 Carol Ochs & Bruce MacVittie  
 Jacki Ochs & Jan Kroeze  
 Elizabeth Peters  
 Peter & Ana Rosa Phillips  
 Oliver Platt & Camilla Campbell Platt  
 Jeremy Posner  
 Dean & Leslie Potashner  
 Peter & Helen Randolph  
 Richard Rauchenberger  
 Willie Reale & Jenny Gersten  
 Theresa Rebeck & Jess Lynn  
 Herald & Linda Ritch

David & Anita Rogerson  
 Robin Morse & Gus Rogerson  
 Mark Saad  
 Steve Sabba  
 Laura Sametz & Anton Fig  
 Karin & Tom Schall  
 Leslie Schine & Nils Nielsen  
 Maury Schott  
 Ken & Mary Ann Schuster  
 Mitchell Semel & Colleen Carroll  
 Tom Shadyac  
 Richard Shaffer & Natakka Bukalo  
 Aaron & Elaine Shapiro  
 Bernice Baruch Shawl  
 Abby Jo Sigal & Matt Turner  
 Meg Simon  
 Talia Balsam & John Slattery  
 Abigail Rose Solomon  
 Jean Stein  
 David & Sara Stone  
 Abby Stranahan & Dave Ward  
 Susanna Styron & Darrell Larson  
 Brian Swardstrom & Bonnie Bernstein  
 Daniel Swee  
 Mariko Tada  
 John Turturro & Katherine Borowitz  
 Laura Valeroso & David Seidman  
 Wendy vanden Heuvel & Brad Coley  
 Ed Vassallo  
 John A. Vassallo  
 Mary Pat Walsh  
 Wendy Wasserstein  
 Sally & Lenny Weiss  
 Jane Bolster & Steve Wertimer  
 Carol Whitesides  
 Michael & Zena Wiener  
 Donald Windham  
 Joanne Woodward & Paul Newman  
 Bill Wrubel & Jennifer Crittenden  
 Jeffrey & Janine Yass  
 James & Mary Lin Yoshimura  
 William & Katherine Zaremby

## The 52nd Street Project presents the 2004 Playback Show

# "IF AT FIRST YOU DON'T SUCCEED..."

## PLAYS THAT TRY AGAIN

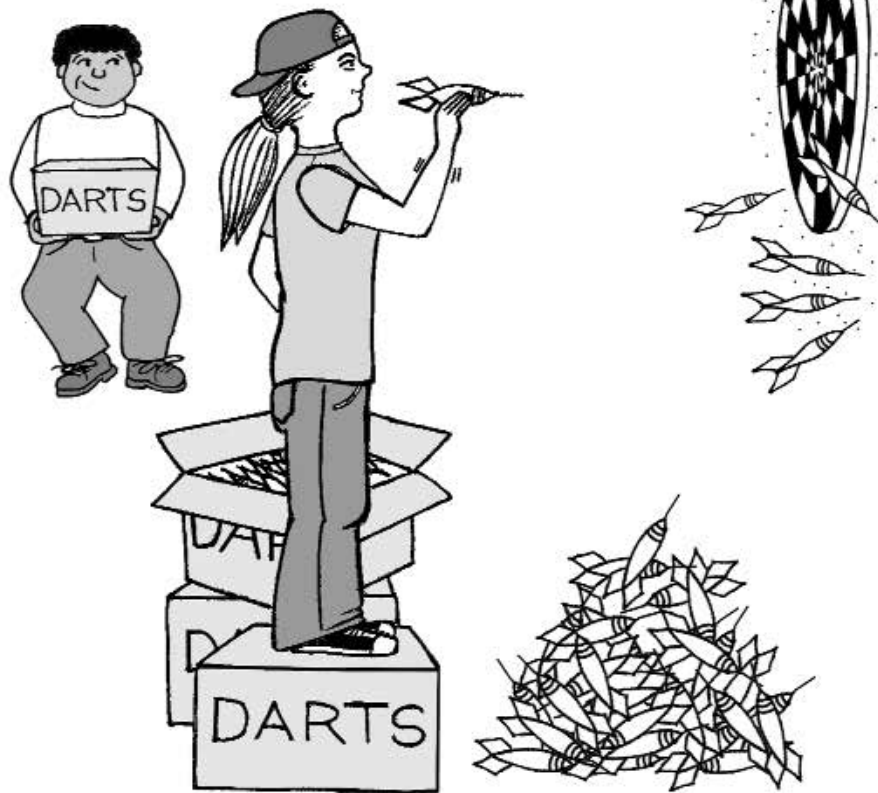

## THEATRE THREE

311 West 43rd St., 3rd Floor.  
 New York City

Fri., February 27 @ 7:30 p.m.,  
 Sat., Feb. 28 @ 3:00 and 7:30 p.m.,  
 Sun., Feb. 29 @ 3:00 p.m.

**IF AT FIRST YOU  
DON'T SUCCEED...  
PLAYS THAT TRY AGAIN**

THE 2004  
PLAYBACK SHOW  
FEBRUARY 27-29  
AT THEATRE THREE

**The 52nd Street Project Staff:**

Gus Rogerson, Artistic Director  
 Carol Ochs, Executive Director  
 John Sheehy, Director of Development and Marketing  
 Megan Sandberg-Zakian, Associate Artistic Director  
 George "X-Acto" Babiak, Production Manager  
 Liz Bell, Director of Education  
 Diana Rojas, Executive Assistant  
 Chris Ceraso, Teen Dean  
 Iris A. Brown, Graphic Designer  
 Mayleen Cancel and Anju Andre-Bergmann, Receptionists  
 Intern: Melanie Levy



**Production Staff:**

**Composer:** Greg Pliska  
**Music Director:** Kari Riely  
**Choreographer:** Jeanne Simpson  
**Set Designer:** Kevin Joseph Roach  
**Lighting Designers:**  
 Greg MacPherson & Kelly Blackwell  
**Costume Designer:** Lora LaVon  
**Costume Assistant:** Jen Caprio  
**Sound Designer:** Betsy Rhodes  
**Stage Manager:** Linda Marvel  
**Slide Designers:**  
 Kent Albin, George Babiak,  
 Chris Bonanos, Nancy Edge,  
 Katherine Lumb, John Steward,  
 Alberta Testanero.

**"If At First" Illustration:** GRB

**Prop Design Team:**

George Babiak, Stephanie Bast,  
 Heather Carnduff, Nikki Fargardo,

Karen Munkel, Lee Rosen,  
 John Sheehy, Jolie Tong,  
 Ed Vassallo

**Furniture Crew:**

Alex Tomas (Boss)  
 & Timothy Thomas

**Prop Crew:**

Rachel Spiers, Melanie Levy,  
 Johanna Vidal, Octavia Rodriguez

**Load-in and Light Hang Crew:**

Kelly Blackwell, Melanie Levy,  
 Linda Marvel, Karen Munkel,  
 Doug Nervik, Christopher Randolph,  
 Lee Rosen, and the great Tom Schall

**House Managers:**

Karin Schall, Liz Bell

**Chefs:**

John Sheehy, Liz Bell,  
 & Bossy Flossy



The Playback Program is made possible with public funds from The New York State Council on the Arts, a state agency. The 52nd Street Project is a member of ART/NY and a participant in the New Generations Program, funded by Doris Duke Charitable Foundation/The Andrew W. Mellon Foundation and administered by Theatre Communications Group, the national organization for the American Theater.



**COOL STUFF ON SALE!**

Flyer Bars .....\$2.00, \$1.50 & \$1.00

*Shel Silverstein's "Fivey and Twoey" logo gear:*

Project Sweatshirts .....\$20.00  
 Project long sleeve t-Shirts .....\$15.00  
 Project Caps .....\$15.00  
 Project Mugs .....\$5.00  
 Project Spiral Notebooks (NEW!) .....\$5.00  
 Project Pencil 3-pack .....\$1.00  
 Rusty Magee CD's .....\$10.00

Thank you for coming to **IF AT FIRST YOU DON'T SUCCEED...** If you are not on our mailing list (or if your address has changed), please fill out this form and give it to us on your way out or mail it to the address below. We would also like to know if you are interested in becoming a volunteer. We need help in **all areas**, so be sure to fill out the entire form.

**PLEASE ADD ME TO YOUR MAILING LIST:**

FEB 2004

NAME: \_\_\_\_\_

ADDRESS: \_\_\_\_\_

\_\_\_\_\_ ZIP \_\_\_\_\_

HOME PHONE: \_\_\_\_\_

DAYTIME PHONE: \_\_\_\_\_

E-MAIL ADDRESS: \_\_\_\_\_

MY OCCUPATION: \_\_\_\_\_

MY HOBBIES: \_\_\_\_\_

**YES, I WOULD LIKE TO BE OF HELP. I CAN:**

- |   |   |  |
|---|---|--|
| <input type="checkbox"/> Help load in and out for shows | <input type="checkbox"/> Draw and/or paint  | <input type="checkbox"/> Help kids with homework |
| <input type="checkbox"/> Hang lights                    | <input type="checkbox"/> Help with mailings | <input type="checkbox"/> Teach kids a skill      |
| <input type="checkbox"/> Work on a backstage crew       | <input type="checkbox"/> Do office work     | <input type="checkbox"/> Be a chef at an event   |
| <input type="checkbox"/> Do graphic design              | <input type="checkbox"/> Design sound       | <input type="checkbox"/> Design and sew costumes |
| <input type="checkbox"/> Other (please specify) _____   |   |  |

**MY SCHEDULE IS:**

- Very flexible. I'm often available during weekdays.  
 Somewhat flexible. I can help on the occasional morning or afternoon during the week.  
 Not very flexible at all, but I've got some free time on evenings and weekends.

If you would like to mail this (and you're always welcome to enclose a tax-deductible contribution), you can send it to: **The 52nd Street Project**, 500 West 52nd St., New York, NY 10019. Or fax it to (212) 333-5598.



## Don't Miss Our Upcoming Shows!

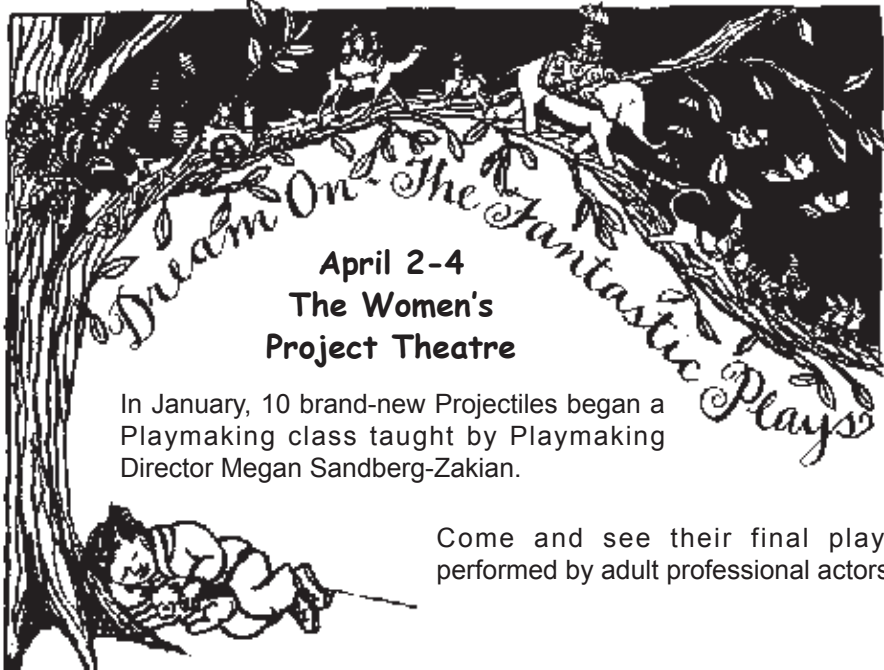

April 2-4  
The Women's  
Project Theatre

In January, 10 brand-new Projectiles began a Playmaking class taught by Playmaking Director Megan Sandberg-Zakian.

Come and see their final plays performed by adult professional actors.

Lewis Black and Jon Stewart, Co-Chairs,  
invite you to save the date for...

# THE PROJECTSHOW WITH JON STEWART

THE MOST IMPORTANT ANNUAL BENEFIT FOR THE 52ND STREET PROJECT, EVER

## MONDAY, MAY 10, 2004

**DON'T MISS IT! THERE WILL BE NO RE-RUN.**

For more information or reservations call John "TIVO" Sheehy @  
**212/333-5252**

The 52nd Street Project is a non-profit organization that brings children from the Hell's Kitchen neighborhood together with professional theater artists to create original theater. **IF AT FIRST** is a production of our **Playback** program, in which kid actor/playwrights wrote plays that were then "answered" by adult actor/playwright partners who write their own plays. We took the whole menagerie up to the idyllic hamlet of Clinton Corners, NY over the Valentine's Day weekend to rehearse the shows. In the final production, which you see here tonight, the partners perform both plays back-to-back. All of the kids involved are veterans of the Playmaking classes which were adapted for the Project by Daniel Judah Sklar from his book *Playmaking: Children Writing and Performing Their Own Plays*.

### The 52nd Street Project Board of Directors

Ben Barenholtz  
Lisa Benavides  
Rachel Chanoff  
Cathy Dantchik  
Noël Dawkins  
Wendy Ettinger,  
*chair emeritus*  
Louis P. Friedman  
Stephen Graham, *chair*  
Larry Jones  
James McDaniel  
Frances McDormand  
Patricia M. Murphy, Esq.

Carol Ochs  
Willie Reale,  
*founder*  
Gus Rogerson  
Shirley Rumierk,  
*alumni member*  
José Soto, Jr.,  
*alumni member*  
Pamala Tyson  
Laura Valeroso  
Wendy vanden Heuvel  
John A. Vassilaros  
Jenny Wiener

### Special Thanks

We're extremely grateful to **Maria Tucci and Robert Gottlieb, Griffin Dunne, and Terry Fitzpatrick and Stephen Perepeluk** for providing us with luxurious housing during our trip upstate. Thanks also to the **TheaterWorks Costume Shop** for loaning us some cool duds.

### In-Kind Contributions

We are also indebted to Neil A. Mazzella and Hudson Scenic Studios; the Murphy Law Office; Iris A. Brown; Ron Kastner and Capital Printing; Kenneth Cole Productions; Noggin; Scholastic, Inc.; Diageo Chateau & Estate Wines; Entertainment Weekly; Alison Fraser; Newman's Own; Sesame Workshop; Wendy Stuhlberg; Tarte, Inc.; Terax America; John A. Vassilaros; Watkins, Inc.; Mayor's Office of Film & Television; Boylan's Bottling Co.; David Sneddon & Fairway Market; Steve Olsen & The Westbank Cafe; Lorraine Tobias & Imaginary Studios; Jive Records, part of Zomba Music Group, Playwrights Horizons, Ensemble Studio Theatre; and Prime Films.

## IF AT FIRST YOU DON'T SUCCEED - ACT I

All original music composed by Greg Pliska

### The Jock and the Geek

By Jeremy Butler, age 13. Dramaturg/Director: Carlo Alban

**Dr. Spencer and Mr. Cool** Written and directed by Carlo Alban

Spencer .....Jeremy Butler  
Chris .....Carlo Alban  
Other Jock .....Alex Tomas  
Voice of Mr. Wolf .....Timothy Thomas  
Other students .....The Crew

*"A Little Cool-Aid"* lyrics by Carlo Alban

### The Decision

By Anthony Mejia, age 14. Dramaturg: Jerome Hairston  
Director: Stephanie Bast

### The Heart of a Madman

Written by Jerome Hairston and directed by Stephanie Bast

Wild Joe .....Anthony Mejia  
Bonny .....Stephanie Bast  
Cop .....Timothy Thomas  
Teller .....Melanie Levy

### Out of the Box

By Anastasia Kehr, age 13. Dramaturg/Director: Danny Goldstein

**Under Your Nose** Written and directed by Danny Goldstein

Liberty .....Ani Kehr  
Liberty's kid brother/Red .....Danny Goldstein  
Television reporter/Small child .....John Sheehy  
*"Closet Monster"* lyrics by Danny Goldstein

### I'm Sorry

By Wonkezeh Newenle, age 15. Dramaturg: Megan Sandberg-Zakian  
Directed by George Babiak

**I'm Sorry II** Written by Michael Bernard. Directed by George Babiak

Andrew .....Wonkezeh Newenle  
Kate .....Phyllis Somerville  
Supermarket Workers .....Johanna Vidal, Timothy Thomas  
Waiters .....Alex Tomas, Octavia Rodriguez  
Violinists .....Kari Riely, George Babiak

*"Sorry to See You Hurt"* lyrics by Wonkezeh Newenle

👉 **Intermission!** 👈

## IF AT FIRST YOU DON'T SUCCEED - ACT II

### The Help of a Friend

By Adalberto Rodriguez, age 14. Dramaturg/Director: Ed Vassallo

**Which Friend Should You Help?** Written and directed by Ed Vassallo

Jet .....Berto Rodriguez  
Peanut .....Ed Vassallo  
Malf .....Alex Tomas  
The Girl .....Melanie Levy

### The Best of Both Worlds

By Solangee Acosta, age 14. Dramaturg/Director: Lee Rosen

**When Both Worlds Collide**

Written and directed by Lee Rosen

Chris .....Solangee Acosta  
Janay .....Lee Rosen  
Other kids .....The Crew

*"Project Z"* lyrics by Lee Rosen

### Dreams

By Ariana Casablanca, age 14. Dramaturg/Director: Erin Quinn Purcell

### Dreams II

Written and directed by Erin Quinn Purcell

Brenda .....Ariana Casablanca  
Jessica .....Erin Quinn Purcell  
Josh .....Alex Tomas  
Voice of the Stage Manager .....Johanna Vidal

*"The Truth About Friendship"* lyrics by Ariana Casablanca

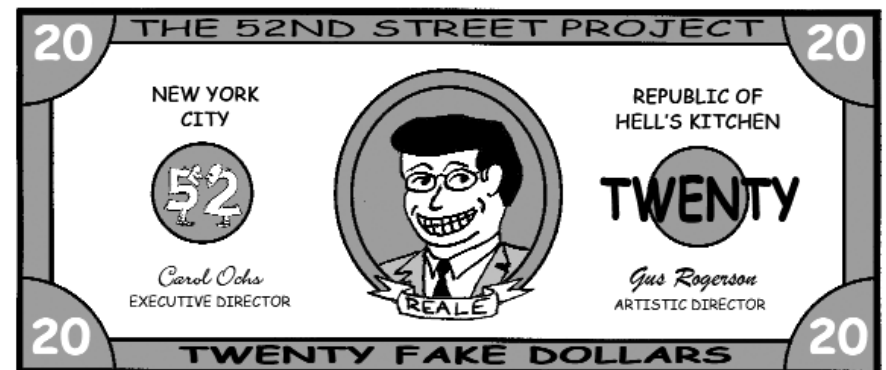

The 52nd Street Project gratefully acknowledges the support of the following foundations and corporations: Altria Employee Fund, Barker Welfare Foundation, The Barnsley Foundation, Bloomberg, Blythmour Corporation, California Comedy, Capital Research Company, Carnegie Corporation of New York, Comedy Central, Davis Polk & Wardwell, Deutsche Bank of Americas Foundation, The Dramatists Guild Fund, Dramatists Play Service, Eleanor, Adam & Mel Dubin Foundation, Entertainment Weekly, The Horace W. Goldsmith Foundation, The William and Mary Greve Foundation, The Hennessy Foundation, Holland Lodge Foundation, Inc., Lloyds TSB Bank plc, Lucille Lortel Foundation, James A. Macdonald Foundation, Major League Baseball, Ann M. Martin Foundation, Mellon Bank, N.A., The New World Foundation, The New York Times Company Foundation, Newman's Own, Norcross Wildlife Foundation, Inc., Pfizer Foundation, Rytech Inc., St. James' Church, The Fan Fox & Leslie R. Samuels Foundation, Stranahan Foundation, Susquehanna Partners, G.P., Tiger Baron Foundation, John A. Vassilaros & Son, Inc., The Vervane Foundation, The Wiener Family Foundation, Zagat Survey, Felix Zaremba & Co. Inc. In addition the following individuals made gifts of over \$200 to The 52nd Street Project this year (list is current as of 4/1/04):

Jace Alexander & Maddie Corman	Angelina Fiordellisi	Linda Li	Laura Sametz & Anton Fig
Lucie Amaz & Laurence Luckinbill	Alexa Fogel	Adrienne Lobel & Mark Linn Baker	Karin & Tom Schall
Dylan & Becky Baker	David Frankel	John Lyons	Leslie Schine & Nils Nielsen
Ben Barenholtz	Frank Frattaroli	Grace Lyu-Volckhausen	Maury Schott
Jessica Bauman	Katherine Freedman	Greg MacPherson & Jane Perlmutter	Ken & Mary Ann Schuster
Laurie Becker & Rick Sweren	Naomi Freundlich & Charles Miles	Nat Magee & Alison Fraser	Lauren Seikaly & Michael Huber
Meredith Beeuwkes	Louis & Patrice Friedman	Wendy Makkena & Bob Krakower	Mitchell Semel & Colleen Carroll
Lisa Benavides & Tim Nelson	Janeane Garofalo	Doda Manalansan	Tom Shadyac
Vicky Bijur & Ed Levine	Rose Gasner & Larry Chertoff	Donald Margulies & Lynn Street	Richard Shaffer & Natalka Bukalo
Lewis Black	Ileen Getz & Mark Grinnell	Kay Matschullat & Allan Arffa	Aaron & Elaine Shapiro
Richard Blackstone & Yildez Yuksek	Paul & Liz Giamatti	Paul McCrane & Dana Kellin	Bernice Baruch Shawl
Tessa Blake	Nancy Giles	Fran McDormand & Joel Coen	Peter Shinoda
Buzz Bovshow	Lloyd & Kilty Gilmour	William Michael McMahon & Meg McMahon	Abby Jo Sigal & Matt Turner
Bob Boyett	Judy Goldman & Michael Pillinger	Rick Meese & Dan Lori	Meg Simon
Becky Browder & Ted Neustadt	Tony Goldwyn & Jane Musky	Richard & Denise Menelly	Talia Balsam & John Slattery
Susan Bruce & Peter Hedges	Assembly Member Richard Gottfried	Josie Merck & Jim Stevenson	Abigail Rose Solomon
Alfred C. Cerullo III	Stephen & Cathy Graham	Brian Mertes	Jean Stein
Rachel Chanoff	Michael Greif & Jonathan Fried	Audrey & Danny Meyer	David & Sara Stone
Glenda Chesshir	Connie Grappo & Lee Wilkof	Judy Minor	Abby Stranahan & Dave Ward
Kirk & Katherine Holt Citron	Lisa Gugenheim	Robin Morse & Gus Rogerson	Susanna Styrone & Darrell Larson
Darah Cloud & Dave Owens	Mark & Valerie Hadjipateras	Suzen Murakoshi & Mark Temme	Brian Swardstrom & Bonnie Bernstein
Ruth Cohen	Jane & Jonathan Heine	Patricia M. Murphy, Esq. & Adam Spilka	Daniel Swee
Lieta Heslen-Cohen & Richard Cohn	Peter Herdrich & Karen Trott	Don & Sara Nelson	Mariko Tada
Tricia Cooke & Ethan Coen	William Holtzman & S. Sylvia Shepard	Ruth Nelson	Timothy Thomas
Hyla & Richard Crane	Katy Homans & Patterson Sims	Mark Nesselson, M.D. & Elliott Rosenblum	John Turturro & Katherine Borowitz
Margaret Crimmins	Barbara Howard	Kevin O'Rourke & Edith Thurber	Laura Valeroso & David Seidman
Billy Crudup	Philip & Alexandra Howard	Carol Ochs & Bruce MacVittie	Wendy vanden Heuvel & Brad Coley
Tom Cruise	Dana Ivey	Jacki Ochs & Jan Kroeze	Ed Vassallo
Catherine Curtin	Mark Evan Jacobs	Elizabeth Peters	John A. Vassallo
Willem Dafeo	Sy Jacobs	Peter & Ana Rosa Phillips	Mary Pat Walsh
John J. Dagenhard	Whitney Scott & Peter Jacobson	Oliver Platt & Camilla Campbell Platt	Wendy Wasserstein
Arthur Dantchik	Andrea Johnson	Jeremy Posner	Sally & Lenny Weiss
Cathy Dantchik	Traci Paige Johnson & Robert Mowen	Dean & Leslie Potashner	Jane Bolster & Steve Wertimer
Leslie Dantchik	Kristen Johnston	Peter & Helen Randolph	Carol Whitesides
Peter & Judith Dawkins	Larry & Mary Jones	Richard Rauchenberger	Michael & Zena Wiener
Georgia & William Delano	Aram Kailian	Willie Reale & Jenny Gersten	Donald Windham
Jonathan Demme	Maurice Kanbar	Theresa Rebeck & Jess Lynn	Frank Wood & Jo Porter
Richard & Rebecca Dresser	Ronald Kastner & Vanessa Boeye	Herald & Linda Ritch	Peter & Helen Woodward & Paul Newman
Christopher & Karen Eddowes	Seth & Beth Klarman	David & Anita Rogerson	Bill Wrubel & Jennifer Crittenden
Mario Egozi	Judy Kuhn & David Schwab	Martha Roth & Bill Irwin	James & Mary Lin Yoshimura
David & Chrysti Eigenberg	Allan & Nanette Larson	Mark Saad	William & Katherine Zaremba
Ned Eisenberg & Patricia Maguire	Michael P. Lawrence	Steve Sabba	
Nora Ephron	Mary Ann Lefort		
Wendy Ettinger & Derek McLane	Iana Levine & Dominic Fumusa		
Tom Feeney & Paul Parzuchowski	Joshua Lewis & Sarah Kay		
Peter Jay Fernandez & Denise Burse	Anna Li		
Martin Fetner & William Coury			

## The 52nd Street Project presents



## THE SPRING 2004 PLAYMAKING PLAYS

Fri., April 2 at 7:30 p.m.  
Sat., April 3 at 7:30 p.m.  
Sun., April 4 at 3:00 p.m.

The Women's Project Theater, 424 West 55th Street

**DREAM ON...**  
*The Fantastic Plays*

THE SPRING, 2004  
 PLAYMAKING SHOW  
 APRIL 2-4  
 AT THE WOMEN'S PROJECT

**The 52nd Street Project Staff:**

Gus Rogerson, Artistic Director  
 Carol Ochs, Executive Director  
 John Sheehy, Director of Development and Marketing  
 Megan Sandberg-Zakian, Associate Artistic Director  
 George "X-Acto" Babiak, Production Manager  
 Liz Bell, Director of Education  
 Diana Rojas, Executive Assistant  
 Chris Ceraso, Teen Dean  
 Iris A. Brown, Graphic Designer  
 Mayleen Cancel and Anju Andre-Bergmann, Receptionists



**Production Staff:**

**Composer:** Joel Derfner  
**Music Director:** Patrick Barnes  
**Fight Choreographer:** Tom Schall  
**Set Designer:** Kevin Joseph Roach  
**Lighting Designer:**  
 Greg MacPherson  
**Costume Designer:** Crystal Thompson  
**Costume Assistants:**  
 Bobby Andres and Deb Lucas  
**Sound Designer:** Maury Schott  
**Stage Manager:** Karen Munkel  
**Slide Designers:**  
 George Babiak, Chris Bonanos,  
 Jeremy Harger, Tyra Hillsten,  
 Katherine Lumb, Alexandre Mentha,  
 John Steward, Alberta Testanero,  
 Iwona Waluk  
**"Dream On" Illustration:**  
 Laura Kvasnosky

**Prop Design Team:**

George Babiak, Anju Andre-Bergmann, Stephanie Bast, Nicole Fargardo, Danny Goldstein, Karen Munkel, Lee Rosen

**Furniture Crew:**

Zebulun Santiago, Anthony Mejia, & Eric Fisher

**Prop Crew:**

Nicole Fargardo, Kayelani Silva, & Rachel Spiers

**Load-in and Light Hang Crew:**

Geiselda Beaudin, Kelly Blackwell, Tim Gallagher, Nedra Gallegos, Karen Munkel, Eric Pomert, Kevin Ryder, & the great Tom Schall

**House Managers:**

Karin Schall, Mary Pat Walsh, Liz Bell

**COOL STUFF ON SALE!**

- Flyer Bars .....\$2.00, \$1.50 & \$1.00  
*Shel Silverstein's "Fivey and Twoey" logo gear:*  
 Project Sweatshirts .....\$20.00  
 Project long sleeve t-Shirts .....\$15.00  
 Project Caps .....\$15.00  
 Project Mugs .....\$5.00  
 Project Spiral Notebooks (NEW!) .....\$5.00  
 Project Pencil 3-pack .....\$1.00  
 Rusty Magee CD's .....\$10.00

Thank you for coming to **DREAM ON**. If you are not on our mailing list (or if your address has changed), please fill out this form and give it to us on your way out or mail it to the address below. We would also like to know if you are interested in becoming a volunteer. We need help in **all areas**, so be sure to fill out the entire form.

**PLEASE ADD ME TO YOUR MAILING LIST:**

APR 2004

NAME: \_\_\_\_\_

ADDRESS: \_\_\_\_\_

\_\_\_\_\_ ZIP \_\_\_\_\_

HOME PHONE: \_\_\_\_\_

DAYTIME PHONE: \_\_\_\_\_

E-MAIL ADDRESS: \_\_\_\_\_

MY OCCUPATION: \_\_\_\_\_

MY HOBBIES: \_\_\_\_\_

**YES, I WOULD LIKE TO BE OF HELP. I CAN:**

- |   |   |  |
|---|---|--|
| <input type="checkbox"/> Help load in and out for shows | <input type="checkbox"/> Draw and/or paint  | <input type="checkbox"/> Help kids with homework |
| <input type="checkbox"/> Hang lights                    | <input type="checkbox"/> Help with mailings | <input type="checkbox"/> Teach kids a skill      |
| <input type="checkbox"/> Work on a backstage crew       | <input type="checkbox"/> Do office work     | <input type="checkbox"/> Be a chef at an event   |
| <input type="checkbox"/> Do graphic design              | <input type="checkbox"/> Design sound       | <input type="checkbox"/> Design and sew costumes |
| <input type="checkbox"/> Other (please specify) _____   |   |  |

**MY SCHEDULE IS:**

- Very flexible. I'm often available during weekdays.  
 Somewhat flexible. I can help on the occasional morning or afternoon during the week.  
 Not very flexible at all, but I've got some free time on evenings and weekends.

If you would like to mail this (and you're always welcome to enclose a tax-deductible contribution), you can send it to: **The 52nd Street Project**, 500 West 52nd St., New York, NY 10019. Or fax it to (212) 333-5598.



The Playmaking Program is made possible with public funds from The New York State Council on the Arts, a state agency. The 52nd Street Project is a member of Art/NY and a participant in the New Generations Program, funded by Doris Duke Charitable Foundation/The Andrew W. Mellon Foundation and administered by Theatre Communications Group, the national organization for the American Theater.





**MONDAY, MAY 10, 2004**

**Hosted by  
Jon Stewart and Lewis Black  
with  
Edie Falco and  
Tim Blake Nelson**

**For information  
or reservations  
call  
John Sheehy at  
(212) 333-5252**



**THE** A GALA TO BENEFIT THE 52ND STREET PROJECT, NYC  
**PROJECTSHOW**  
WITH **JON STEWART**

The 52nd Street Project is a non-profit organization that brings children from the Hell's Kitchen neighborhood together with professional theater artists to create original theater. **DREAM ON** is a production of our Playmaking program. Young people participate in a nine-week playwriting course taught by Megan Sandberg-Zakian and adapted for the Project by Daniel Judah Sklar from his book *Playmaking: Children Writing and Performing Their Own Plays*. At the end of the course, each child is given two actors, a theme, and a dramaturg/director who guides him or her through the writing of a play during a weekend retreat in the country (Kent, Connecticut, for this show). Tonight's performance is the end result.

---

**The 52nd Street Project Board of Directors**

- |  |  |
|--|--|
| Ben Barenholtz                           | Carol Ochs                               |
| Lisa Benavides                           | Willie Reale,<br><i>founder</i>          |
| Rachel Chanoff                           | Gus Rogerson                             |
| Cathy Dantchik                           | Shirley Rumierk,<br><i>alumni member</i> |
| Noël Dawkins                             | José Soto, Jr.,<br><i>alumni member</i>  |
| Wendy Ettinger,<br><i>chair emeritus</i> | Pamala Tyson                             |
| Louis P. Friedman                        | Laura Valeroso                           |
| Stephen Graham, <i>chair</i>             | Wendy vanden Heuvel                      |
| Larry Jones                              | John A. Vassilaros                       |
| James McDaniel                           | Jenny Wiener                             |
| Frances McDormand                        |  |
| Patricia M. Murphy, Esq.                 |  |

---

**In-Kind Contributions**

We are also indebted to Neil A. Mazzella and Hudson Scenic Studios; the Murphy Law Office; Iris A. Brown; Ron Kastner and Capital Printing; Kenneth Cole Productions; Noggin; Scholastic, Inc.; Diageo Chateau & Estate Wines; Entertainment Weekly; Alison Fraser; Newman's Own; Sesame Workshop; Wendy Stuhlberg; Tarte, Inc.; Terax America; John A. Vassilaros; Watkins, Inc.; Mayor's Office of Film & Television; Boylan's Bottling Co.; David Sneddon & Fairway Market; Steve Olsen & The Westbank Cafe; Lorraine Tobias & Imaginary Studios; Jive Records, part of Zomba Music Group, Playwrights Horizons, Ensemble Studio Theatre; and Prime Films.

---

**Special Thanks**

We're grateful to **Stephen, Cathy, Juliet, and Tommy Graham** for graciously allowing us to bring the chaos of a Playmaking weekend to their lovely home in Kent, Connecticut. Their staff, including **Miriam** and **Chef Erik**, get a round of applause, too. Thanks also go to **Sam and Lynn Waterston**, and **Oliver and Camilla Platt** for providing accommodations. Thanks also to **Julie Kline, Melanie Levy, and Kate Weisburd** for helping out in Playmaking class.



## DREAM ON - ACT I

All original music composed by Joel Derfner

### The Clumsy One

by Carlos Muentes, age 9. Dramaturg/Director: Glynis Rigsby

Key ..... Joel de la Fuente  
Pen ..... Marsha Stephanie Blake  
“It’s Mean to Be Mean” lyrics by Carlos Muentes

### The Guy Who Lived in the Street

by Angel Silva, age 10. Dramaturg/Director: Joe White

Brad ..... Stephan Kolbert  
Glenn ..... Ephraim Lopez

### The Dead Mother and the Lonely Girl

by Arielle Velasquez, age 12. Dramaturg/Director: Sonia Manzano

Lisa ..... Jessica Walling  
Kathy ..... Lizzy Cooper Davis  
Mother’s Voice ..... Nancy Giles

“Going to Sleep” lyrics by Arielle Velasquez

### Zoe and Phoebe - Friends Forever

by Janiece Krystle Aponte, age 10.

Dramaturg: Liz Bell, Director: Jessica Bauman

Phoebe ..... Deirdre O’Connell  
Zoe ..... Jenny Bacon

“Sad Song” lyrics by Janiece Aponte.

### Friends and Siblings

by Lily Houghton, age 9.

Dramaturg/Director: Mary Pat Walsh

Charlie Supertop ..... Edward O’Blenis  
Rosie Supertop ..... Anita Flanagan  
Cool Kid ..... Kayelani Silva  
Cool Kid Posse ..... Crew

 **Intermission!** 

## DREAM ON - ACT II

### The Boxer and The Dancer

by Dale Fetterman, age 10. Dramaturg/Director: Drew Cortese

Mat Reva ..... Kevin Geer  
Patrosa ..... Nancy Giles  
Boxing Announcer ..... John Sheehy  
Heavyweight Champion Michael Lane ..... George Babiak  
Corner People ..... Crew

### Best Brothers and Good Friends

by Muhammad Cunningham, age 10.

Dramaturg/Director: Michael Potts

Alex ..... Emilio Delgado  
Josh ..... Chris McCann  
Mom ..... Nancy Giles  
Operator ..... John Sheehy

### Dream of the Yankees

by Hera Andre-Bergmann, age 9.

Dramaturg/Director: Erica Schmidt

Nicki Modern ..... Brienan Bryant  
Dazed Dream ..... Katherine Wallach  
Joe Torre ..... George Babiak

### Comet and Bud’s Adventure

by Pablo Maldonado, age 10. Dramaturg/Director: Alex Draper

Comet ..... Edie Falco  
Bud ..... Nate Corddry

“Night Shift” lyrics by Pablo Maldonado.

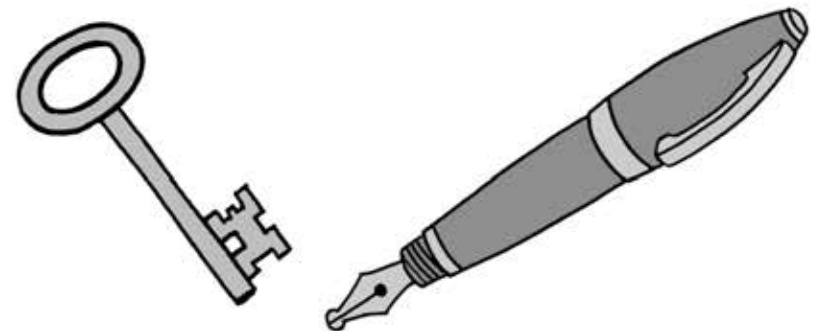

*Honorary Chairs*  
Lewis Black and Jon Stewart  
*and Corporate Hosts*  
Ars Nova PGM,  
Louis Friedman, Bear Stearns  
Tobak-Dantchik Events  
*and the Board of Directors of*  
*The 52nd Street Project present*

# THE PROJECT SHOW

WITH **JON STEWART**



**MONDAY MAY 10, 2004**  
**AT CAPITALE**

**BOARD CHAIR**

Stephen Graham

**EXECUTIVE DIRECTOR**

Carol Ochs

**ARTISTIC DIRECTOR**

Gus Rogerson

## CO-CHAIRS

Lisa Benavides	Patrice Friedman
Becky Browder	Karin Schall
Cathy Dantchik	Laura Valeroso
Louis P. Friedman	Mary Pat Walsh
Jenny Wiener	

## THE BOARD OF DIRECTORS

Ben Barenholtz	Patricia M. Murphy, Esq.
Lisa Benavides	Carol Ochs
Rachel Chanoff	Willie Reale, <i>founder</i>
Cathy Dantchik	Gus Rogerson
Noël Dawkins	Shirley Rumiark, <i>alumni member</i>
Wendy Ettinger, <i>chair emeritus</i>	José Soto, Jr., <i>alumni member</i>
Louis P. Friedman	Pamala Tyson
Stephen Graham, <i>chair</i>	Laura Valeroso
Larry Jones	Wendy vanden Heuvel
James McDaniel	John A. Vassilaros
Frances McDormand	
Jenny Wiener	

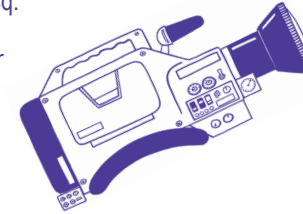

## THE 52ND STREET PROJECT GRATEFULLY ACKNOWLEDGES...

Benefit Cosmetics  
Iris A. Brown  
Bourjois Paris  
Bumble and bumble  
Capital Printing/Ronald J. Kastner  
Kenneth Cole Productions  
Diageo Chateau & Estate Wines Co.  
Entertainment Weekly  
Jive Records  
*A division of Zomba Music Group*  
Lucky Magazine  
Micro Touch/Finishing Touch Trimmers  
Molton Brown  
MOP Cosmetics  
Newman's Own  
Noggin/The N  
Pharma/Omni Printing  
Sesame Workshop  
Wendy Stulberg  
Terax America  
John A. Vassilaros & Sons  
Watkins Incorporated  
*Healthier Living Since 1868*

## THE PROJECT SHOW CAST

### THE ADULTS

Lewis Black  
Rob Corddry  
Edie Falco  
Tim Blake Nelson  
and  
Jon Stewart

### THE KIDS

John Cuevas  
Christopher Ramirez  
Jennifer Ramirez  
Johanna Vidal

### DIRECTED BY

Jonathan Bernstein

### WRITTEN BY

Willie Reale &  
John Sheehy

### SET DESIGN

George Babiak &  
Kevin Joseph Roach

### LIGHTING DESIGN

Greg MacPherson &  
Jason Wells

### COSTUME DESIGN

Crystal Thompson

### SOUND DESIGN

Tom Morse

### STAGE MANAGER

Hank Meiman

### FOAMCORE CARPENTRY

George Babiak

## **BANNER HEADLINERS**

Arthur Dantchik  
Cathy Dantchik  
Patrice & Louis Friedman, Bear Sterns  
Cathy & Stephen Graham  
Jenny Wiener & Jon Steingart, Ars Nova  
Jeff Yass

## **LATE-BREAKING STORY TELLERS**

Comedy Central  
Wendy Ettinger & Derek McLane  
Sy Jacobs  
Paulette & Jeremy Posner  
Joanne Woodward & Paul Newman

## **LOCAL COLOR COMMENTATORS**

Tom Cruise  
The Dawkins Family Foundation  
Amy Friedman, Noggin/The N  
Alexandra Gersten-Vassilaros & Johnny  
Coffeeshopolis  
HBO  
Michelle Katz  
Fred Nelson, Entertainment Weekly  
Clea Newman  
David Pecker, American Media  
Ana Rosa & Peter Phillips, Lloyds TSB  
Maury Schott  
Sesame Workshop  
Laura Valeroso & David Seidman  
Wendy vanden Heuvel  
Randall Weisenburger

## **SENIOR ANALYSTS**

Gavin Berger & Craig Berggren	Nancy Giles
Elizabeth & Alexander Bernstein	Susan Jacobs
Linda & Arthur Carter	Kristen Johnston
Alfred C. Cerullo, III	Deborah & James Kern
Kathleen Clark & Richard Frankel	Steve Klinsky
Jennifer Crittendon & Bill Wrubel	John S. Lyons
Leslie Dantchik	Betsy MacIsaac & Robert Goldberg, Yorke Construction Corp.
Nora Ephron	Sonia Manzano & Richard Reagan
Frank Frattaroli	Josephine Merck & Jim Stevenson
Janeane Garofalo	Audrey & Danny Meyer



Walter Mosley	Mark Roberts
Michelle Mulitz & Morty Gudelsky	Anita A. & David S. Rogerson
Rona & Randy Nelson	Daryl Roth
Sara & Don Nelson	Steve Sabba
Jane Perlmutter & Greg MacPherson	Sarah & Jeff Stafford
Elizabeth Peters	Jane & R.L. Stine
Lise Rehmaldt	Adriana Trigiani & Tim Stephenson
Theresa Rebeck & Jess Lynn	Mary Pat Walsh
Michael Ritchie	Frank Wood
	Mary Lin & Jim Yoshimura

## **BUREAU CHIEFS**

Anonymous	Renee Edelman
Cecilia Arana-Grant & Dr. Kevin Grant	Paul Ferrara
Emily Armstrong	Liz Fillo & Chris Coucill
Adam Leitman Bailey	Anita Flanagan
Becky & Dylan Baker	Alison Fraser & Nat Magee
June Ballinger & Michael Goldstein	Rose Gasner & Larry Chertoff
Vera Ann Baquet & Vicki Rundberg-Rivera	Jenny Gersten & Willie Reale
Ben Barenholtz	Ileen Getz & Mark Grinnell
Lisa Benavides & Tim Blake Nelson	Amy & George Goldstein
Stephen Bernstein	Carol & Larry Goldstein
Jane Bolster & Steve Wertimer	Connie Grappo & Lee Wilkof
Buzz Bovshow	Lisa J. Gugenheim & Lawrence Nathanson
Rick Boynton	Wendy & Alan Halpern
Jon Brielle	Laura Hamilton
Kathryn Briggs, Dramatists Play Service	Jane & Jonathan Heine
Becky Browder & Ted Neustadt	Amy Herzig
Susan Bruce & Peter Hedges	Katy Homans & Patterson Sims
Denise Burse & Peter Jay Fernandez	Sarah Horowitz & David Venarde
Cora Cahan & Bernard Gersten	Charlie Huntley
Camilla Campbell	Donna & Thomas Jaycox
Kassie Canter	Amanda Johns
Colleen Carroll & Mitchell Semel	Julie Johns
Heather Carter	Aram Kailian & Teni Apelian
Constance Casey & Harold Varmus	Sheryl Kaller & Scott Zaretsky
Rachel Chanoff	Cindy Kaplan & David Froelich
Sharon Chantiles	Sarah Kay & Josh Lewis
David Copeland	Pat Kirby
David Costabile	Belle & Roger Kuhn
William Coury & Martin Fettner	Liza Lerner
Rebecca & Daniel Day-Lewis	Aimee Levine
Yvonne DeSanti	Ilana Levine, Dominic Fumusa & Georgia Levi Fumusa
Paula Devicq & Joe Taylor	Anna Antonia Li
Rebecca & Richard Dresser	Katherine Lumb
Bonnie Dry	Bruce MacVittie
Patricia Dunnock & Ned Eisenberg	Sonya Martin
Tana & Bill Dye	Brigid McCarthy
Karen & Chris Eddowes	Barbara McCrane & Paul Reale
	Frances McDormand & Joel Coen
	Marianne & Andrew McKeon
	Rick Meese & Dan Lori
	Emily & John Morgan
	Maia & Sham Mosher

Suzen Murakoshi & Mark Temme	Landon Slane
Laura & Richard Murawczyk	Lois Smith
Patricia Murphy & Adam Spilka	John Steber & Robert Shaffron
Frank Napolitano	Joel Stigliano, Dramatists Play Service
Jacki Ochs & Jan Kroeze	Lynn Street & Donald Margulies
Sascha Paladino	Wendy Stulberg & David Nanasi
Susan Ochs Phillips	Susanna Styron & Darrell Larson
Judy & Michael Pillinger	Daniel Swee
Katharyn Pinder	Lili Taylor
Eric Pomert	Edith Thurber & Kevin O'Rourke
Kelly Powell	Lorraine Tobias & Alex Draper
Christopher Randolph	Anne Torsiglieri & Michael Bernard
Robert Reale	Karen Trott & Peter Herdrich
Martha Roth & Bill Irwin	Cynthia Vance & Robert Abrams
Julie Rottenberg & Ben Rubin	Susan J. Vitucci
Laura Rovinsky & Bruce Grossberg	Brenda Wehle & John C. Lynch
Laura Sametz & Anton Fig	Ali Marsh Weller & Fred Weller
Karin & Thomas Schall	Carol Whitesides
David Schwab	Max Wilk
Whitney Scott & Peter Jacobson	George Xenos
Jeffrey Seller	Yildiz Yuksek & Richard Blackstone
Sylvia Shepard & Will Holtzman	Paul Zakian
Seth Shepsle & Michael Sheehan	Elisa Zuritsky & Jordan Barowitz
Meg Simon	

List current as of 5/5/04

## **THE 52ND STREET PROJECT STAFF**

Gus Rogerson, Artistic Director  
Carol Ochs, Executive Director  
John Sheehy, Dir. of Development and Marketing  
George Babiak, Production Manager  
Megan Sandberg-Zakian, Associate Artistic Director  
Liz Bell, Director of Education  
Diana Rojas, Executive Assistant  
Chris Ceraso, Teen Dean  
Iris A. Brown, Graphic Designer

## **BENEFIT VOLUNTEERS**

Susan Ash, Jack Babin, Perry McBain Daniel, Adam Felber, Danny Goldstein, Bryan Gmitter, Ray Harold, Tucker Howard, Sheryl Kaller, Eric Migliorini, Catherine Mueller, Karen Munkel, Kari Riely, Lee Rosen, Kim D. Sherman, Jeanne Simpson, Vanessa Valdes, Ed Vassallo, Dan Wojnar

## **SPECIAL THANKS**

Becky Browder, William Curran, Beth Emelson, Liz Flahive, Terry Fitzpatrick, Amy Friedman, Jenny Gersten, Mark Jacobs, John Laird, Barbara McCrane, Christopher Randolph, Karin & Tom Schall, Mary Pat Walsh



**The 52nd Street Project** is a non-profit organization that brings children from the Hell's Kitchen neighborhood together with professional theater artists to create original theater. The Replay program gives children who are graduates of the Project's Playmaking class a chance to hone their skills in an advanced writing workshop taught by Megan Sandberg-Zakian. Over the nine weeks of Replay class, these young playwrights explored varied sources of inspiration, including a visit to the Whitney Museum and two trips to the theater, studied dramatic structure, and learned to embrace the dreaded rewrite. The resulting plays are featured in tonight's reading.

### Special Thanks

We're grateful to **Jenny Wiener, Jon Steingart, and Ars Nova Theater** for making this evening possible. The plays wouldn't have made it to the page without the help of the Replay class volunteers: **Megan Cramer, Jeff LaGreca, Carolyn Nastro, Adam Robinson, Charlie Tocantins, and Malinda Walford**. Big ups to **Rosa Hires and Sally Morse at Dodger Theatricals** for hooking the class up with tickets to the toe tappin' "*42nd Street*", and to **Marianna Houston and Lisa Poyer** for providing us with an excellent model of good playwriting by sending us to "*Raisin in the Sun*."

### The Project Staff

Gus Rogerson ..... Artistic Director  
Carol Ochs ..... Executive Director  
John Sheehy ..... Director of Development  
Megan Sandberg-Zakian ..... Associate Artistic Director  
George Roman Babiak ..... Production Manager  
Liz Bell ..... Director of Education  
Diana Rojas ..... Executive Assistant  
Chris Ceraso ..... Teen Dean  
Iris A. Brown ..... Graphic Designer  
Anju Andre-Bergmann, Mayleen Cancel ..... Receptionists  
Andrew Kelsey, Emily Meisler, Reese Smith ..... Interns

### The 52nd Street Project Board of Directors

Ben Barenholtz  
Lisa Benavides  
Rachel Chanoff  
Cathy Dantchik  
Noël Dawkins  
Wendy Ettinger,  
*chair emeritus*  
Louis P. Friedman  
Stephen Graham, *chair*  
Larry Jones  
James McDaniel  
Frances McDormand  
Patricia M. Murphy, Esq.

Carol Ochs  
Willie Reale,  
*founder*  
Gus Rogerson  
Shirley Rumierk,  
*alumni member*  
José Soto, Jr.,  
*alumni member*  
Pamala Tyson  
Laura Valeroso  
Wendy vanden Heuvel  
John A. Vassilaros  
Jenny Wiener

The 52nd Street Project Presents

---

# THE 2004 REPLAY READINGS

---

## 13 PLAYS BY 13 YOUNG PLAYWRIGHTS

Monday, June 21, 2004

The Ars Nova Theater  
511 West 54th St.

## Colormania

by Stephanie Vamvoukakis, age 10. Directed by Julia Gibson

Blue Man 1 ..... John Conlee  
Pink Girl 1 ..... Frances McDormand

## Walk and Don't Walk's Big Break

by Jason Peterson Ridge, age 10. Directed by Megan Sandberg-Zakian

Walk ..... Chris Ceraso  
Don't Walk ..... Michael Stuhlberg  
The Boss ..... Adam Robinson

## Two Personalities, One Person

by Nicole Fargardo, age 13. Directed by Maria Goyanes

Rosie ..... Malinda Walford  
Jake ..... Jeff LaGreca  
Outer Ellen ..... Kate Forbes  
Voice of God ..... Maria Goyanes  
Inner Ellen ..... Maile Holck

## The Stealing Changes

by Jennifer Ramirez, age 10. Directed by Julia Gibson

Jason ..... Kenajuan Bentley  
Michael ..... John Conlee  
Wife ..... Frances McDormand

## A Friendship of a Teacher and a Stupidhead

by Isaac Goodman Boyd, age 11. Directed by Megan Sandberg-Zakian

Hilly Billy Bob ..... Michael Stuhlberg  
Mr. Ogglethorpe ..... Chris Ceraso

## The Interruption

by Aladino Olivares, age 13. Directed by Elizabeth Giamatti

Johnny ..... Robert Jimenez  
Rico ..... George Babiak  
Mikie ..... John Sheehy  
Mom ..... Diana Rojas

## Circus is Pure Evil

by Matthew Ortiz, age 11. Directed by Seret Scott

Clab ..... Abigail Lopez  
Cho ..... Bruce MacVittie  
Rhino ..... Mario Quesada  
Guard 1 ..... Andrew Kessler  
Guard 2 ..... Charise Smith  
Juggler ..... Seret Scott

## AIDS in Texas

by Erica Arce, age 10. Directed by Maria Goyanes

Samantha ..... Kate Forbes  
Mom: ..... Malinda Walford  
Lisa ..... Maile Holck

## Two Mermaids in Love

by Luz Maldonado, age 11. Directed by Seret Scott

Mariel ..... Abigail Lopez  
Fish ..... Mario Quesada  
Bill ..... Bruce MacVittie

## The Woman That Suicided Herself

by Steven Castellanos, age 12. Directed by Julia Gibson

Alan ..... John Conlee  
Rosie ..... Frances McDormand  
News Reporter ..... Andrew Kessler  
Maria ..... Julia Gibson

## Ryan Normal

by Skye Blu Welsh, age 12. Directed by Seret Scott

Ryan ..... Bruce MacVittie  
Mikey ..... Mario Quesada  
Sarah ..... Abigail Lopez

## Growing Up The Wrong Way

by Andrew John Welsh, age 11. Directed by Elizabeth Giamatti

Cesario ..... Robert Jimenez  
Boss ..... George Babiak  
Tony ..... John Sheehy  
Guy/Christopher ..... Charlie Tocantins

## Time is Money

by Harlo Ulloa, age 11. Directed by Megan Sandberg-Zakian

Mat ..... Michael Stuhlberg  
Dad/Teacher ..... Adam Robinson  
Jim ..... Chris Ceraso

# B R I E F I N T E R M I S S I O N



The 52nd Street Project gratefully acknowledges the support of the following foundations and corporations: American Media; Barker Welfare Foundation; Bloomberg; Capital Research Company; Carnegie Corporation of New York; Citigroup; Consolidated Edison; Comedy Central; The Dramatists Guild Fund; Dramatists Play Service; The Max & Victoria Dreyfus Foundation Inc.; Eleanor, Adam & Mel Dubin Foundation; Entertainment Weekly; The Hennessy Foundation; HBO; Holland Lodge Foundation, Inc.; The Horace W. Goldsmith Foundation; Hurlbut Family Charitable Lead Trust; JKW Foundation; Betty E. & George B. Kaiser Foundation; Lloyds TSB Bank plc; Lucille Lortel Foundation; James A. Macdonald Foundation; Mad.House, Inc.; Ann M. Martin Foundation; Mellon Equity Associated, LLP; The New World Foundation; The New York Times Company Foundation; Newman's Own; Armstrong Nickoll Family Foundation; Noggin; Norcross Wildlife Foundation, Inc.; The Fan Fox & Leslie R. Samuels Foundation; Sesame Workshop; Stranahan Foundation; The Surdna Foundation; Theatre Communications Group, Inc.; The Vervane Foundation; John A. Vassilaros & Son, Inc; Yorke Construction Corporation; Felix Zarembo & Co. Inc. In addition the following individuals made gifts of over \$200 to The 52nd Street Project this year (list is current as of 6/30/04):

Robert Abrams & Cynthia Vance	Janeane Garofalo	Doda Manalansan	Daryl Roth
Cecilia Arana-Grant & Kevin Grant	Rose Gasner & Larry Chertoff	Paul & Lauren Mandell	Martha Roth & Bill Irwin
Adam Leitman Bailey	Alexandra Gersten &	Sonia Manzano &	Steve Sabba
Ben Barenholtz	John Vassilaros	Richard Reagan	Arnold & Agnes Sametz
Jessica Bauman	Cora Cahan & Bernard Gersten	Donald Margulies & Lynn Street	Laura Sametz & Anton Fig
Laurie Becker & Rick Sweren	Nancy Giles	Gene & Mary Ann McCoy	Karin & Tom Schall
Meredith Beeuwkes	Lloyd & Kilty Gilmour	Paul McCrane & Dana Kellin	Maury Schott
Lisa Benavides & Tim Nelson	Judy Goldman & Michael Pillingier	Fran McDormand & Joel Coen	Lauren Seikaly & Michael Huber
Gavin Berger & Craig Berggren	George & Amy Goldstein	Andrew McKeon	Jeffrey Seller & Joshua Lehrer
Alexander & Elizabeth Bernstein	Larry & Carol Goldstein	Rick Meese & Dan Lori	Mitchell Semel & Colleen Carroll
Jeanette & Samuel Black	Stephen & Cathy Graham	Danny Meisner	Aaron & Elaine Shapiro
Tessa Blake	Connie Grappo & Lee Wilkof	Josie Merck & Jim Stevenson	Pam Shaw & Victor Szymis
Buzz Bovshew	Emily Grishman & Susan Sampliner	Brian Mertes	Seth Shepsle
Jon Brielle	Bruce Grossberg & Laura Rovinsky	Audrey & Danny Meyer	Peter Shinoda
Kathy Briggs	Lisa Gugenheim	Judy Minor	Meg Simon
Becky Browder & Ted Neustadt	Alan Halperin & Wendy Halperin	Emily & John Morgan	Landon Slane
Deborah Brown	Jane & Jonathan Heine	Mala & Sham Mosher	Jeff Stafford
Susan Bruce & Peter Hedges	Peter Herdrich & Karen Trott	Walter Mosley	John Steber & Robert Shaffron
Kate Burton & Michael Ritchie	Amy Herzig	Michelle Multiz & Morty Gudelsky	Jean Stein
Linda & Arthur Carter	William Holtzman &	Suzen Murakoshi & Mark Temme	R.L. Stine & Jane Stine
Constance Casey	S. Sylvia Shepard	Richard Murawczyk	Susanna Styron & Darrell Larson
Alfred C. Cerullo III	Katy Homans & Patterson Sims	& Laura Murawczyk	Daniel Swee
Rachel Chanoff	Sarah Horowitz & David Venarde	Patricia M. Murphy, Esq.	Timothy Thomas
Lieta Hesen-Cohen & Richard Cohn	Sy Jacobs	& Adam Spilka	Adriana & Tim Stephenson
Billy Crudup	Donna & Thomas Jaycox	Frank Napolitano	Laura Valeroso & David Seidman
Tom Cruise	Amanda Johns	Steven Neiditz & Leslie Neiditz	Wendy vanden Heuvel &
Arthur Dantchik	Andrea Johnson	Don & Sara Nelson	Brad Coley
Cathy Dantchik	Kristen Johnston	Randy & Rona Nelson	Susan Vitucci
Leslie Dantchik	Larry & Mary Jones	Clea Newman	Mary Pat Walsh
Peter & Judith Dawkins	Aram Kailian & Eli Pariser	Edward Norton	Brenda Wehle & John C. Lynch
Alex Draper & Lorraine Tobias	Sheryl Kaller	Kevin O'Rourke & Edith Thurber	Randall Weisenburger
Richard & Rebecca Dresser	Cindy Kaplan	Carol Ochs & Bruce MacVittie	Sally & Lenny Weiss
Christopher & Karen Eddowes	Michelle Katz	Jacki Ochs & Jan Kroeze	Ali Marsh
Renee Edelman	James Kern & Deborah Kern	Paul & Maria Onderdonk	Jane Bolster &
David & Chrysti Eigenberg	Steven Klinsky	Sascha Paladino	Steve Wertimer
Ned Eisenberg & Patricia Maguire	Mary Kong	Elizabeth Peters	Jenny Wiener & Jon Steingart
Nora Ephron	Judy Kuhn & David Schwab	Peter & Ana Rosa Phillips	Michael & Zena Wiener
Wendy Ettinger & Derek McLane	Liza Lerner	Susan Ochs Phillips	Donald Windham
Peter Jay Fernandez & Denise Burse	Ilana Levine & Dominic Fumusa	Katharyn Pinder	Frank Wood
Martin Fetner & William Coury	Joshua Lewis & Sarah Kay	Jeremy & Paulette Posner	Joanne Woodward &
Liz Fillo	Anna Li	Peter & Helen Randolph	Paul Newman
David Frankel	Katherine Lumb	Paul Reale & Barbara McCrane	Bill Wrubel & Jennifer Crittenden
Richard Frankel & Kathleen Clark	John Lyons	Willie Reale & Jenny Gersten	Patricia Xenos
Alison Fraser & Nat Magee	Grace Lyu-Volckhausen	Theresa Rebeck & Jess Lynn	Jeffrey & Janine Yass
Frank Frattaroli	Greg MacPherson &	Lise Rehwaldt & Mark Roberts	James & Mary Lin Yoshimura
Louis & Patrice Friedman	Jane Perlmutter	David & Anita Rogerson	Elisa Zuritsky & Jordan Barowitz

The 52nd Street Project presents  
The 2004 Harold and Mimi Steinberg Charitable Trust One-on-Ones

# LOCATION, LOCATION: THE LOCATION PLAYS



JAMES STEVENSON

## DESTINATION: BLOCK ISLAND

July 22-25, 2004

The Ensemble Studio Theatre  
549 West 52nd St.  
NEW YORK CITY

# LOCATION, LOCATION THE LOCATION PLAYS

The 2004 Block Island  
One-on-Ones  
July 22-25  
The Ensemble  
Studio Theatre

## The 52nd Street Project Staff:

Gus Rogerson, Artistic Director  
Carol Ochs, Executive Director  
John Sheehy, Director of Development and Marketing  
Megan Sandberg-Zakian, Associate Artistic Director  
George "X-Acto" Babiak, Production Manager  
Liz Bell, Director of Education  
Diana Rojas, Executive Assistant  
Chris Ceraso, Teen Dean  
Iris A. Brown, Graphic Designer  
Mayleen Cancel, Receptionist  
Interns: Andrew Kelsey, Emily Meisler and Reese Smith

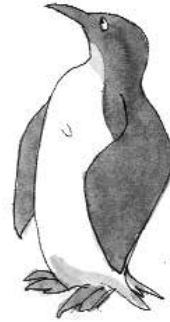

## Production Staff

### Composer:

Kim D. Sherman

### Set Designer:

Kevin Joseph Roach

### Lighting Designer:

Greg MacPherson

### Costume Designer:

Bryan Gmitter

### Goddess of Sound:

Vanessa Valdes

### Stage Manager:

Perry McBain Daniel

### Slide Design Team:

Chris Bonanos, Johann Conforme,  
Lee Kimble, Katherine Lumb,  
Kathleen Maloney, Mike Marshall, Robin  
Marshall, Monty Nicol, John Steward,  
James Stevenson, Alberta Testanero,  
Iwona Waluk

### Prop Design Team:

George Babiak, Stephanie Bast,

Nicole Fargardo, Andrew Kelsey,

Ephraim Lopez and Thom, Sophia Ochs  
MacVittie, John Sheehy, Joaquín Torres,  
Michael Velez

### Flyer/Program Illustrations:

James Stevenson

### Furniture Crew:

Andrew Kelsey and Michael Velez

### Prop Crew:

Nicole Fargardo, Leah Galimidi,  
Emily Meisler, Reese Smith

### Load-in and Light-hang Crew:

Kelly Blackwell, Leah Galimidi,  
Ray Harold, Doug Nervik, Christopher  
Randolph, Joaquín Torres

### House Managers:

Liz Bell, Liz Flahive, Karin Schall

### Chefs:

Pat Ritter and Martha Velie-Gass

### Teen Counselor:

Leah Galimidi

## COOL STUFF ON SALE IN THE LOBBY!

The Fabulous Flyer Bar . . . . . \$2, \$1.50 & \$1  
and featuring Shel Silverstein's "Five and Twoey" logo:

Project T-shirts (NEW Design) . . . . . \$12.00  
Project Tank Tops (NEW Girls' Design) . \$12.00  
Project Caps (NEW design) . . . . . \$15.00  
Project Mugs (now in BLUE!) . . . . . \$5.00  
Project Pencil 3-pack (now in RED!) . . . . \$1.00  
Project Notebook (New Item) . . . . . \$5.00

Thank you for coming to **LOCATION, LOCATION!** If you are not on our mailing list (or if your address has changed), please fill out this form and give it to us on your way out or mail it to the address below. We would also like to know if you are interested in becoming a volunteer. We need help in **all areas**, so be sure to fill out the entire form.

### PLEASE ADD ME TO YOUR MAILING LIST:

7/04

NAME: \_\_\_\_\_

ADDRESS: \_\_\_\_\_

ZIP \_\_\_\_\_

HOME PHONE: \_\_\_\_\_

DAYTIME PHONE: \_\_\_\_\_

E-MAIL ADDRESS: \_\_\_\_\_

MY OCCUPATION: \_\_\_\_\_

MY HOBBIES: \_\_\_\_\_

### YES, I WOULD LIKE TO BE OF HELP. I CAN:

- |   |   |  |
|---|---|--|
| <input type="checkbox"/> Help load in and out for shows | <input type="checkbox"/> Draw and/or paint  | <input type="checkbox"/> Help kids with homework |
| <input type="checkbox"/> Hang lights                    | <input type="checkbox"/> Help with mailings | <input type="checkbox"/> Teach kids a skill      |
| <input type="checkbox"/> Work on a backstage crew       | <input type="checkbox"/> Do office work     | <input type="checkbox"/> Be a chef at an event   |
| <input type="checkbox"/> Do graphic design              | <input type="checkbox"/> Design sound       | <input type="checkbox"/> Design and sew costumes |
| <input type="checkbox"/> Other (please specify) _____   |   |  |

### MY SCHEDULE IS:

- Very flexible. I'm often available during weekdays.  
 Somewhat flexible. I can help on the occasional morning or afternoon during the week.  
 Not very flexible at all, but I've got some free time on evenings and weekends.

If you would like to mail this (and you're always welcome to enclose a tax-deductible contribution), you can send it to: **The 52nd Street Project**, 500 West 52nd St., New York, NY 10019. Or fax it to (212) 333-5598.



The One-on-Ones Program is made possible with public funds from The New York State Council on the Arts, a state agency; and the New York City Department of Cultural Affairs. The 52nd Street Project is supported by funds from the National Endowment for the Arts, the Department of Youth and Community Development. The Project is member of ART/NY and a participant in the New Generations Program, funded by Doris Duke Charitable Foundation/The Andrew W. Mellon Foundation and administered by Theatre Communications Group, the national organization for the American Theater.



## Don't Miss Our Upcoming Shows!

# LOCATION, LOCATION: THE LOCATION PLAYS

VOLUME  
2



DESTINATION:  
WAREHAM

The second outing of the 2004 One-on-Ones August 21-24 right here at E.S.T. Same great theme, but with new kids, new adults, and all-new plays. Come again!

## PLAYBACK

November, 2004

First a kid writes a short play. Then, an adult writes an "answer" play. Then, the two of them perform both plays. Multiply this equation by seven and you've got an entire show.



December, 2004

In September, 10 kids brand-new to the Project will begin a Playmaking class taught by Project Playmaking Director Megan Sandberg-Zakian. Come and see their final plays performed by adult professional actors.

The 52nd Street Project is a non-profit organization that brings children from the Hell's Kitchen neighborhood together with professional theater artists to create original theater. **LOCATION, LOCATION** is a production of our One-on-One program, which is designed to give children the opportunity to go away for one-week stays in the country and enjoy the undivided attention of a professional theater artist who serves as friend, mentor, and collaborator. The Project is delighted to return to the Ensemble Studio Theatre, where we have been performing since our inception in 1981. We gratefully acknowledge the fact that if E.S.T. wasn't here, we'd be nowhere.

### The 52nd Street Project Board of Directors

Ben Barenholtz

Lisa Benavides

Rachel Chanoff

Cathy Dantchik

Noël Dawkins

Wendy Ettinger, *chair emeritus*

Louis P. Friedman

Stephen Graham, *chair*

Larry Jones

James McDaniel

Frances McDormand

Patricia M. Murphy, Esq.

Carol Ochs

Willie Reale, *founder*

Gus Rogerson

Shirley Rumierk, *alumni member*

José Soto, Jr., *alumni member*

Pamala Tyson

Laura Valeroso

Wendy vanden Heuvel

John A. Vassilaros

Jenny Wiener

### Special Thanks

Our Host Families – Josie Merck & Jim Stevenson; Alan & Roberta Alpert; Jennifer & Elliot Taubman; Sue Black; Jane Muskey & Tony Goldwyn; Ron, Judy & Kevin Tierney; Joya Verde & Virginia Dare; Thomas Frye and our headquarters host Dr. Christina Biaggi. Sincere thanks also go to Lynn Reale, Kate & Harold at Block Island Realty; Rita & Steve Draper; Glenn & Annie Hall; McQuade's Market; Interstate Navigation; Bruce & Sophia Ochs MacVittie; Jenny Ritter; Amanda Gass; Kirk Littlefield; Joe & Pat at Smuggler's Cove Sailing School; Finns Fish Market; Ed McGovern; Ed Berube; the Block Island Grocery; Cindy & Stan Greer at The Depot; Bill Bendokis at New England Airlines; Gary Pollard at The Empire Theater; Robin Morse, Lucy & Francis Rogerson; Wendy vanden Heuvel and Lila Blue Coley; and our amazing chefs Pat Ritter & Martha Velie-Gass

### In-Kind Contributions

Curt, John, Mary, Carl, Tim, and everyone at the Ensemble Studio Theatre; the Murphy Law Office; Benefit Cosmetics; Iris A. Brown; Bourjois Paris; Bumble and bumble; Ron Kastner and Capital Printing; Kenneth Cole Productions; Noggin; The Printing Store; Scholastic, Inc.; Diageo Chateau & Estate Wines; Entertainment Weekly; Lucky Magazine; Microtouch/Finishing Touch; Molten Brown; MOP Cosmetics; Newman's Own; Pharma Print/Omni Graphics; Sesame Workshop; Wendy Stuhlberg; Terax America; John A. Vassilaros; Watkins, Inc.; Mayor's Office of Film & Television; Boylan's Bottling Co.; David Sneddon & Fairway Market; Lorraine Tobias & Imaginary Studios; Jive Records, part of Zomba Music Group; and Prime Films.



## LOCATION, LOCATION - ACT 1

All original music composed by Kim D. Sherman  
"Location, Location Theme Song" lyrics by John Sheehy

### THE GOOD SOLDIER

Written & Directed by Stephen Barker Turner for Angel Silva, age 10

Jace .....Angel Silva  
Sergeant Strongheart .....Stephen Barker Turner  
Girl .....Leah Galimidi

"The Ready Song," "The Rightness Song," "The Love Song," "The Why Song,"  
"The Surprise Song" lyrics by Stephen Barker Turner

### UNDERGROUND

Written & Directed by Nina Daniels for Muhammad Cunningham, age 10

Lady .....Nina Daniels  
Rat .....Muhammad Cunningham  
Bystanders .....Andrew Kelsey & Leah Galimidi

"Smooth Rat" lyrics by Nina Daniels & John Sheehy

### CITY STORY

Written & Directed by Erica Schmidt for Jennifer Ramirez, age 10

Shelby Lauren .....Erica Schmidt  
Crystal James .....Jennifer Ramirez

"What's Your Name" lyrics by Erica Schmidt

### ON LOCATION

Written by James Stevenson & Directed by Joaquín Torres  
for Pablo Maldonado, age 10

Larry Morris .....Joaquín Torres  
Boris Grossoff .....Pablo Maldonado

"Boris Is Back" lyrics by James Stevenson

### FOWL PLAY

Written & Directed by Eris Migliorini for Stephanie Vamvoukakis, age 10

Birdra Bokoran .....Eris Migliorini  
Myrtle McCluck .....Stephanie Vamvoukakis  
Capon Wattle .....Gus Rogerson  
Marty .....George Babiak

"Look in the Mirror" lyrics by Eris Migliorini

## LOCATION, LOCATION - ACT 2

### ARMANDO

Written by Willie Reale & Directed by Diana Rojas for Kayelani Silva, age 13

Rosalinda .....Diana Rojas  
Pina .....Kayelani Silva  
Armando .....Andrew Kelsey

"Armando" and "Nobody Here But Us" lyrics by Willie Reale

### HOW MASTER LY GOT HIS GROOVE BACK

Written & Directed by Kate Marks for George Zapata, age 10

Master Ly .....George Zapata  
Little Z .....Kate Marks

"The Monk's Lament" lyrics by Kate Marks

### THE ADVENTURES OF CAPTAIN FUNK AND DR. KNOCKOUT

Written & Directed by Ross M. Berger for Jonathan Rosario, age 11

Captain Funk .....Ross M. Berger  
Dr. Knockout .....Jonathan Rosario  
Negativity Man .....George Babiak  
Narrator .....Gus Rogerson

"Generic Theme Song aka Schmaggegy" lyrics by Ross M. Berger & John Sheehy

### THE AMAZING DR. JUNGLE

Written by Daniel Goldfarb & Directed by Becky White  
for Arielle Velasquez, age 12

Dr. Jungle .....Arielle Velasquez  
Serena .....Becky White

"Itchy's Song" lyrics by Daniel Goldfarb

### FOOLS RUSSIAN

Written & Directed by John Sheehy for Jason Peterson Ridge, age 11

Sergei .....John Sheehy  
Alexei .....Jason Ridge  
Ringmaster .....Andrew Kelsey

"I Can't Hold On" lyrics by John Sheehy

👉 **Intermission!** 👈



The 52nd Street Project gratefully acknowledges the support of the following foundations and corporations: American Media; Barker Welfare Foundation; Bloomberg; Capital Research Company; Carnegie Corporation of New York; CBS, Citigroup; Consolidated Edison; Comedy Central; The Dramatists Guild Fund; Dramatists Play Service; The Max & Victoria Dreyfus Foundation Inc.; Eleanor, Adam & Mel Dubin Foundation; Entertainment Weekly; The Henlopen Foundation, The Hennessy Foundation; HBO; Holland Lodge Foundation, Inc.; The Horace W. Goldsmith Foundation; Hurlbut Family Charitable Lead Trust; JKW Foundation; Betty E. & George B. Kaiser Foundation; Lloyds TSB Bank plc; Lucille Lortel Foundation; James A. Macdonald Foundation; Mad House, Inc.; Ann M. Martin Foundation; Mellon Equity Associated, LLP; The New World Foundation; The New York Times Company Foundation; Newman's Own; Armstrong Nickoll Family Foundation; Noggin; Norcross Wildlife Foundation, Inc.; The Fox & Leslie R. Samuels Foundation; Sesame Workshop; Stranahan Foundation; The Surdna Foundation; Theatre Communications Group, Inc.; The Vervane Foundation; John A. Vassilaros & Son, Inc; Yorke Construction Corporation; Felix Zaremba & Co. Inc. In addition the following individuals made gifts of over \$200 to The 52nd Street Project this year (list is current as of 6/30/04):

Robert Abrams & Cynthia Vance	Janeane Garofalo	Doda Manalansan	Daryl Roth
Cecilia Arana-Grant & Kevin Grant	Rose Gasner & Larry Chertoff	Paul & Lauren Mandell	Martha Roth & Bill Irwin
Adam Leitman Bailey	Alexandra Gersten &	Sonia Manzano &	Steve Sabba
Ben Barenholtz	John Vassilaros	Richard Reagan	Arnold & Agnes Sametz
Jessica Bauman	Cora Cahan & Bernard Gersten	Donald Margulies & Lynn Street	Laura Sametz & Anton Fig
Laurie Becker & Rick Sweren	Nancy Giles	Gene & Mary Ann McCoy	Karin & Tom Schall
Meredith Beeuwkes	Lloyd & Kilty Gilmour	Paul McCrane & Dana Kellin	Maury Schott
Lisa Benavides & Tim Nelson	Judy Goldman & Michael Pillingier	Fran McDormand & Joel Coen	Lauren Seikaly & Michael Huber
Gavin Berger & Craig Berggren	George & Amy Goldstein	Andrew McKeon	Jeffrey Seller & Joshua Lehrer
Alexander & Elizabeth Bernstein	Larry & Carol Goldstein	Rick Meese & Dan Lori	Mitchell Semel & Colleen Carroll
Jeanette & Samuel Black	Stephen & Cathy Graham	Danny Meisner	Aaron & Elaine Shapiro
Tessa Blake	Connie Grappo & Lee Wilkof	Josie Merck & Jim Stevenson	Pam Shaw & Victor Szymis
Buzz Bovshov	Emily Grishman & Susan Sampliner	Brian Mertes	Seth Shepsola
Jon Brielle	Bruce Grossberg & Laura Rovinsky	Audrey & Danny Meyer	Peter Shinoda
Kathy Briggs	Lisa Gugenheim	Judy Minor	Meg Simon
Becky Browder & Ted Neustadt	Alan Halperin & Wendy Halperin	Emily & John Morgan	Landon Slane
Deborah Brown	Jane & Jonathan Heine	Mala & Sham Mosher	Jeff Stafford
Susan Bruce & Peter Hedges	Peter Herdrich & Karen Trott	Walter Mosley	John Steber & Robert Shaffron
Kate Burton & Michael Ritchie	Amy Herzig	Michelle Mulitz & Morty Gudelsky	Jean Stein
Linda & Arthur Carter	William Holtzman &	Suzen Murakoshi & Mark Temme	R.L. Stine & Jane Stine
Constance Casey	S. Sylvia Shepard	Richard Murawczyk	Susanna Styron & Darrell Larson
Alfred C. Cerullo III	Katy Homans & Patterson Sims	& Laura Murawczyk	Daniel Swee
Rachel Chanoff	Sarah Horowitz & David Venarde	Patricia M. Murphy, Esq.	Timothy Thomas
Lieta Hesen-Cohen & Richard Cohn	Sy Jacobs	& Adam Spilka	Adriana & Tim Stephenson
Billy Crudup	Donna & Thomas Jaycox	Frank Napolitano	Laura Valeroso & David Seidman
Tom Cruise	Amanda Johns	Steven Neiditz & Leslie Neiditz	Wendy vanden Heuvel &
Arthur Dantchik	Andrea Johnson	Don & Sara Nelson	Brad Coley
Cathy Dantchik	Kristen Johnston	Randy & Rona Nelson	Susan Vitucci
Leslie Dantchik	Lary & Mary Jones	Clea Newman	Mary Pat Walsh
Peter & Judith Dawkins	Aram Kailian & Eli Pariser	Edward Norton	Brenda Wehle & John C. Lynch
Alex Draper & Lorraine Tobias	Sheryl Kaller	Kevin O'Rourke & Edith Thurber	Randall Weisenburger
Richard & Rebecca Dresser	Cindy Kaplan	Carol Ochs & Bruce MacVittie	Sally & Lenny Weiss
Christopher & Karen Eddowes	Michelle Katz	Jacki Ochs & Jan Kroeze	Ali Marsh
Renee Edelman	James Kern & Deborah Kern	Paul & Maria Onderdonk	Jane Bolster &
David & Chrysti Eigenberg	Steven Klinsky	Sascha Paladino	Steve Wertimer
Ned Eisenberg & Patricia Maguire	Mary Kong	Elizabeth Peters	Jenny Wiener & Jon Steingart
Nora Ephron	Judy Kuhn & David Schwab	Peter & Ana Rosa Phillips	Michael & Zena Wiener
Wendy Ettinger & Derek McLane	Liza Lerner	Susan Ochs Phillips	Donald Windham
Peter Jay Fernandez & Denise Burse	Ilana Levine & Dominic Fumusa	Katharyn Pinder	Frank Wood
Martin Fetner & William Coury	Joshua Lewis & Sarah Kay	Jeremy & Paulette Posner	Joanne Woodward &
Liz Fillo	Anna Li	Peter & Helen Randolph	Paul Newman
David Frankel	Katherine Lumb	Paul Reale & Barbara McCrane	Bill Wrubel & Jennifer Crittenden
Richard Frankel & Kathleen Clark	John Lyons	Willie Reale & Jenny Gersten	Patricia Xenos
Alison Fraser & Nat Magee	Grace Lyu-Volckhausen	Theresa Rebeck & Jess Lynn	Jeffrey & Janine Yass
Frank Frattaroli	Greg MacPherson &	Lise Rehwaldt & Mark Roberts	James & Mary Lin Yoshimura
Louis & Patrice Friedman	Jane Perlmutter	David & Anita Rogerson	Elisa Zuritsky & Jordan Barowitz

The 52nd Street Project presents  
The 2004 Wiener Family Foundation One-on-Ones

# LOCATION, LOCATION: THE LOCATION PLAYS

Vol.  
2



JAMES STEVENSON

## DESTINATION: WAREHAM, MASS.

August 20-22, 2004  
The Ensemble Studio Theatre  
549 West 52nd St.  
NEW YORK CITY

# LOCATION, LOCATION THE LOCATION PLAYS

The 2004 Wareham, MA  
One-on-Ones  
August 20-22  
The Ensemble  
Studio Theatre

## The 52nd Street Project Staff:

Gus Rogerson, Artistic Director  
Carol Ochs, Executive Director  
John Sheehy, Director of Development and Marketing  
Megan Sandberg-Zakian, Associate Artistic Director  
George "X-Acto" Babiak, Production Manager  
Liz Bell, Director of Education  
Diana Rojas, Executive Assistant  
Chris Ceraso, Teen Dean  
Iris A. Brown, Graphic Designer  
Mayleen Cancel, Receptionist  
Interns: Andrew Kelsey, Emily Meisler and Reese Smith

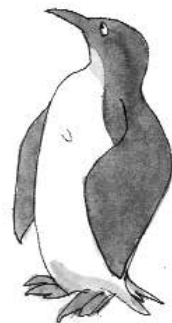

## Production Staff

**Composer:** Patrick Barnes  
**Set Designer:** Kevin Joseph Roach  
**Lighting Designer:** Greg MacPherson  
**Costume Designer:** K. O'Reilly  
**Sound Designer:** Andrew Kelsey  
**Stage Manager:** Karen Munkel  
**Slide Design Team:**

Chris Bonanos, Johann Conforme,  
Lee Kimble, Katherine Lumb,  
Kathleen Maloney, Mike Marshall, Robin  
Marshall, Monty Nicol, Mike Sell, John  
Steward, Alberta Testanero, Iwona Waluk

## Prop Design Team:

Hera Andre-Bergmann, George Babiak,  
Liz Bell, Kelly Blackwell, Noel Kvasnosky,  
Luz Maldonado, Emily Meisler, Karen  
Munkel, Megan Sandberg-Zakian, John  
Sheehy, Reese Smith

**Location Illustration:** Jim Stevenson  
**Furniture Crew:**

Luis Anthony Maldonado and  
Christopher Ramirez

## Prop Crew:

Emily Meisler, Reese Smith, and  
Anthony Mejia

## Load-in and Light-hang Crew:

Andrew Kelsey, Emily Meisler,  
Reese Smith, Luis Anthony  
Maldonado and the staff

## House Managers:

Liz Bell, Liz Flahive, Mary Pat Walsh

## Chefs:

Christopher Randolph, Liz Bell,  
John Sheehy, Carol Ochs

## Teen Counselor:

Luis Anthony Maldonado

The One-on-Ones Program is made possible with public funds from The New York State Council on the Arts, a state agency; and the New York City Department of Cultural Affairs. The 52nd Street Project is supported by funds from the National Endowment for the Arts, the Department of Youth and Community Development. The Project is member of ART/NY and a participant in the New Generations Program, funded by Doris Duke Charitable Foundation/The Andrew W. Mellon Foundation and administered by Theatre Communications Group, the national organization for the American Theater.



## COOL STUFF ON SALE IN THE LOBBY!

The Fabulous Flyer Bar . . . . . \$2, \$1.50 & \$1  
and featuring Shel Silverstein's "Five and Twoey" logo:  
Project T-shirts (NEW Design) . . . . . \$12.00  
Project Tank Tops (NEW Girls' Design) . \$12.00  
Project Caps (NEW design) . . . . . \$15.00  
Project Mugs (now in BLUE!) . . . . . \$5.00  
Project Pencil 3-pack (now in RED!) . . . . \$1.00  
Project Notebook (New Item) . . . . . \$5.00

Thank you for coming to **LOCATION, LOCATION!** If you are not on our mailing list (or if your address has changed), please fill out this form and give it to us on your way out or mail it to the address below. We would also like to know if you are interested in becoming a volunteer. We need help in **all areas**, so be sure to fill out the entire form.

### PLEASE ADD ME TO YOUR MAILING LIST:

8/04

NAME: \_\_\_\_\_

ADDRESS: \_\_\_\_\_

ZIP \_\_\_\_\_

HOME PHONE: \_\_\_\_\_

DAYTIME PHONE: \_\_\_\_\_

E-MAIL ADDRESS: \_\_\_\_\_

MY OCCUPATION: \_\_\_\_\_

MY HOBBIES: \_\_\_\_\_

### YES, I WOULD LIKE TO BE OF HELP. I CAN:

- |   |   |  |
|---|---|--|
| <input type="checkbox"/> Help load in and out for shows | <input type="checkbox"/> Draw and/or paint  | <input type="checkbox"/> Help kids with homework |
| <input type="checkbox"/> Hang lights                    | <input type="checkbox"/> Help with mailings | <input type="checkbox"/> Teach kids a skill      |
| <input type="checkbox"/> Work on a backstage crew       | <input type="checkbox"/> Do office work     | <input type="checkbox"/> Be a chef at an event   |
| <input type="checkbox"/> Do graphic design              | <input type="checkbox"/> Design sound       | <input type="checkbox"/> Design and sew costumes |
| <input type="checkbox"/> Other (please specify) _____   |   |  |

### MY SCHEDULE IS:

- Very flexible. I'm often available during weekdays.  
 Somewhat flexible. I can help on the occasional morning or afternoon during the week.  
 Not very flexible at all, but I've got some free time on evenings and weekends.

If you would like to mail this (and you're always welcome to enclose a tax-deductible contribution), you can send it to: **The 52nd Street Project**, 500 West 52nd St., New York, NY 10019. Or fax it to (212) 333-5598.

## Don't Miss Our Upcoming Shows!

# PLAYBACK

## nothing up my sleeve: *The Deceptive Plays*

October, 2004

First a kid writes a short play. Then, an adult writes an "answer" play. Then, the two of them perform both plays. Multiply this equation by seven and you've got an entire show.



## MORPH FOR THE MONEY: *Plays with Change*

December, 2004

In September, 10 kids brand-new to the Project will begin a Playmaking class taught by Project Playmaking Director Megan Sandberg-Zakian. Come and see their final plays performed by adult professional actors.

The 52nd Street Project is a non-profit organization that brings children from the Hell's Kitchen neighborhood together with professional theater artists to create original theater. **LOCATION, LOCATION** is a production of our One-on-One program, which is designed to give children the opportunity to go away for one-week stays in the country and enjoy the undivided attention of a professional theater artist who serves as friend, mentor, and collaborator. The Project is delighted to return to the Ensemble Studio Theatre, where we have been performing since our inception in 1981. We gratefully acknowledge the fact that if E.S.T. wasn't here, we'd be nowhere.

### The 52nd Street Project Board of Directors

Ben Barenholtz	Patricia M. Murphy, Esq.
Lisa Benavides	Carol Ochs
Rachel Chanoff	Willie Reale, <i>founder</i>
Cathy Dantchik	Gus Rogerson
Noël Dawkins	Shirley Rumierk, <i>alumni member</i>
Wendy Ettinger, <i>chair emeritus</i>	José Soto, Jr., <i>alumni member</i>
Louis P. Friedman	Pamala Tyson
Stephen Graham, <i>chair</i>	Laura Valeroso
Larry Jones	Wendy vanden Heuvel
James McDaniel	John A. Vassilaros
Frances McDormand	Jenny Wiener

### Special Thanks

Our Host Families – Emily & John Morgan; Larry Stifler & Mary McFadden; Patty & David Strauss; Sidney Worthen & David Pearce; Beth McNay; Joe McNay; Marina & Bob Whitman; our swimming hosts – Anne & Colin McNay; Alice & Ron Curtin; and our headquarters host – Peter, Helen & Christopher Randolph.

Sincere thanks to our super chef Christopher Randolph; Vanessa Valdes; Kurt Wootton; Robin Morse & Lucy & Francis Rogerson; Sophia Ochs MacVittie; Bob Krystofolski

### In-Kind Contributions

Curt, John, Mary, Carl, Tim, and everyone at the Ensemble Studio Theatre; the Murphy Law Office; Benefit Cosmetics; Iris A. Brown; Bourjois Paris; Bumble and bumble; Ron Kastner and Capital Printing; Kenneth Cole Productions; Noggin; The Printing Store; Scholastic, Inc.; Diageo Chateau & Estate Wines; Entertainment Weekly; Lucky Magazine; Microtouch/Finishing Touch; Molten Brown; MOP Cosmetics; Newman's Own; Pharma Print/Omni Graphics; Sesame Workshop; Wendy Stuhlberg; Terax America; John A. Vassilaros; Watkins, Inc.; Mayor's Office of Film & Television; Boylan's Bottling Co.; David Sneddon & Fairway Market; Lorraine Tobias & Imaginary Studios; Jive Records, part of Zomba Music Group; and Prime Films.

## LOCATION, LOCATION - ACT 1

All original music composed by Patrick Barnes  
"Location, Location (Vol. 2) Theme Song" lyrics by John Sheehy

### MALL GIRL RETURNS

Written by Jackie Reingold & Directed by Shirley A. Rumierk  
for Katherine Alvarez, age 13.

Mall Girl .....Katherine Alvarez  
Tacky Girl .....Shirley A. Rumierk

"She's Mall Girl" & "A Tragic Tale" lyrics by Jackie Reingold

### BEAN THE BOZO

Written & Directed by George Babiak for Hera Andre-Bergmann, age 10

Corky O'Rourke .....Hera Andre-Bergmann  
Griff Thomas .....George Babiak  
Vinnie .....Luis Anthony Maldonado  
Peachface .....Reese Smith

"Platitude Adjustment" lyrics by George Babiak

### THE TEXAS CHAINSAW MATCH OCCURRED

Written & Directed by Bruce MacVittie for Aladino Olivares, age 13

Lewis .....Aladino Olivares  
Clovis .....Bruce MacVittie  
Chainsaw and various victims .....Anthony Mejia, Reese Smith,  
Christopher Ramirez, Luis Anthony Maldonado

"Someone Like You" lyrics by Bruce MacVittie

### METER? I HARDLY KNOW HER

Written by Megan Sandberg-Zakian & Directed by Jennifer Ostrega  
for Luz Maldonado, age 11

Madge Wright .....Luz Maldonado  
Raquel Pasquetti .....Jennifer Ostrega  
Parking Commissioner Pasquetti .....John Sheehy  
Vinnie .....Luis Anthony Maldonado

"You Gotta Keep Time" lyrics by Megan Sandberg-Zakian

### A TAD EXCELLENT ADVENTURE

Written & Directed by Reg Flowers for Bryant Acosta, age 11

Tad Excellent .....Bryant Acosta  
Mr. V .....Reg Flowers  
Slug .....Luis Anthony Maldonado

"I'm Gonna Bring You Down" lyrics by Reg Flowers

## LOCATION, LOCATION - ACT 2

### FAKE IT LIKE YOU MEAN IT

Written by Liza Steinberg & Directed by Megan Cramer  
for Merlaine Mendez, age 12

Jessica Z .....Merlaine Mendez  
Daphne Star .....Megan Cramer  
Announcer .....Reese Smith

"In My Own Words" lyrics by Liza Steinberg

### CHUNK-A-CHANGE GUARANTEED

Written & Directed by Ed Vassallo for Chassity Damiani, age 12

Miss Metamorph .....Chassity Damiani  
Larry .....Ed Vassallo  
Man .....Anthony Mejia  
Peachface .....Reese Smith

"Don't Wanna Be A Dog" lyrics by Ed Vassallo

### THE WILL

Written by Michael Bernard & Directed by Drew Cortese  
for Junior Chatman, age 12

Trevor .....Junior Chatman  
Ernest Terwilliger/Uncle Theopolis .....Drew Cortese  
Wolfgang O'Smellowitz .....Christopher Ramirez

"Not Scared" lyrics by Michael Bernard

### FOR WHOM THE BELLHOP TOILS

Written by Liz Tuccillo & Directed by Zabryna Guevara for Carla Olivia, age 11

Betty the Bellhop .....Carla Olivia  
Veronica Johnstone a.k.a. Sally Smith .....Zabryna Guevara  
Cow .....Luis Anthony Maldonado  
Hog .....Christopher Ramirez  
Duck .....Emily Meisler  
Chicken .....Reese Smith  
Sheep .....Anthony Mejia

"The Bellhop Hop" & "The Special Treatment" lyrics by Liz Tuccillo

### TROUBADOUR TO DOOR

Written by Liz Flahive & Directed by Susan McGinnis  
for Andrew John Welsh, age 11

Max .....Andrew John Welsh  
Laurabelle .....Susan McGinnis  
Bobby the Cruise Director .....John Sheehy

"We'll Get There," "Max's Ultimatum," and "While I Was Out" & lyrics by Liz  
Flahive

 **Intermission!** 

The 52nd Street Project gratefully acknowledges the support of the following foundations and corporations: American Media; Barker Welfare Foundation; Bloomberg; Capital Research Company; Carnegie Corporation of New York; CBS; Citigroup; Consolidated Edison; Comedy Central; The Dramatists Guild Fund; Dramatists Play Service; The Max & Victoria Dreyfus Foundation Inc.; Eleanor, Adam & Mel Dubin Foundation; Entertainment Weekly; The Henlopen Foundation; The Hennessy Foundation; HBO; Holland Lodge Foundation, Inc.; The Horace W. Goldsmith Foundation; Hurlbut Family Charitable Lead Trust; JKW Foundation; Betty E. & George B. Kaiser Foundation; Lloyds TSB Bank plc; Lucille Lortel Foundation; James A. Macdonald Foundation; Mad.House, Inc.; Ann M. Martin Foundation; Mellon Equity Associated, LLP; The New World Foundation; The New York Times Company Foundation; Newman's Own; Armstrong Nickoll Family Foundation; Noggin; Norcross Wildlife Foundation, Inc.; The Fox & Leslie R. Samuels Foundation; Sesame Workshop; Stranahan Foundation; The Surdna Foundation; Theatre Communications Group, Inc.; The Vervane Foundation; John A. Vassilaros & Son, Inc; Yorke Construction Corporation; Felix Zarembo & Co. Inc. In addition the following individuals made gifts of over \$200 to The 52nd Street Project this year (list is current as of 6/30/04):

Robert Abrams & Cynthia Vance	Louis & Patrice Friedman	Jane Perlmutter	David & Anita Rogerson
Cecilia Arana-Grant & Kevin Grant	Janeane Garofalo	Doda Manalansan	Daryl Roth
Adam Leitman Bailey	Rose Gasner & Larry Chertoff	Paul & Lauren Mandell	Martha Roth & Bill Irwin
Ben Barenholtz	Alexandra Gersten &	Sonia Manzano &	Steve Sabba
Jessica Bauman	John Vassilaros	Richard Reagan	Arnold & Agnes Sametz
Laurie Becker & Rick Sweren	Cora Cahan & Bernard Gersten	Donald Margulies & Lynn Street	Laura Sametz & Anton Fig
Meredith Beeuwkes	Nancy Giles	Gene & Mary Ann McCoy	Karin & Tom Schall
Lisa Benavides & Tim Nelson	Lloyd & Kitty Gilmour	Paul McCrane & Dana Kellin	Maury Schott
Gavin Berger & Craig Berggren	Judy Goldman & Michael Pillingier	Fran McDormand & Joel Coen	Lauren Seikaly & Michael Huber
Alexander & Elizabeth Bernstein	George & Amy Goldstein	Andrew McKeon	Jeffrey Seller & Joshua Lehrer
Jeanette & Samuel Black	Larry & Carol Goldstein	Rick Meese & Dan Lori	Mitchell Semel & Colleen Carroll
Lewis Black	Stephen & Cathy Graham	Danny Meisner	Aaron & Elaine Shapiro
Tessa Blake	Connie Grappo & Lee Wilkof	Josie Merck & Jim Stevenson	Pam Shaw & Victor Syrmis
Buzz Bovshow	Emily Grishman & Susan Sampliner	Brian Mertes	Seth Shepsle
Jon Brielle	Bruce Grossberg & Laura Rovinsky	Audrey & Danny Meyer	Peter Shinoda
Kathy Briggs	Lisa Gugenheim	Judy Minor	Meg Simon
Becky Browder & Ted Neustadt	Alan Halperin & Wendy Halperin	Emily & John Morgan	Landon Slane
Deborah Brown	Jane & Jonathan Heine	Mala & Sham Mosher	Jeff Stafford
Susan Bruce & Peter Hedges	Peter Herdrich & Karen Trott	Walter Mosley	John Steber & Robert Shaffron
Kate Burton & Michael Ritchie	Amy Hertzig	Michelle Mulitz & Morty Gudelsky	Jean Stein
Linda & Arthur Carter	William Holtzman &	Suzen Murakoshi & Mark Temme	R.L. Stine & Jane Stine
Constance Casey	S. Sylvia Shepard	Richard Murawczyk	Susanna Styron & Darrell Larson
Alfred C. Cerullo III	Katy Homans & Patterson Sims	& Laura Murawczyk	Daniel Sweet
Rachel Chanoff	Sarah Horowitz & David Venarde	Patricia M. Murphy, Esq.	Timothy Thomas
Lieta Hesen-Cohen & Richard Cohn	Sy Jacobs	& Adam Spilka	Adriana & Tim Stephenson
Billy Crudup	Donna & Thomas Jaycox	Frank Napolitano	Laura Valeroso & David Seidman
Tom Cruise	Amanda Johns	Steven Neiditz & Leslie Neiditz	Wendy vanden Heuvel &
Arthur Dantchik	Andrea Johnson	Don & Sara Nelson	Brad Coley
Cathy Dantchik	Kristen Johnston	Randy & Rona Nelson	Susan Vitucci
Leslie Dantchik	Larry & Mary Jones	Clea Newman	Mary Pat Walsh
Peter & Judith Dawkins	Aram Kailian & Eli Pariser	Edward Norton	Brenda Wehle & John C. Lynch
Alex Draper & Lorraine Tobias	Sheryl Kaller	Kevin O'Rourke & Edith Thurber	Randall Weisenburger
Richard & Rebecca Dresser	Cindy Kaplan	Carol Ochs & Bruce MacVittie	Sally & Lenny Weiss
Christopher & Karen Eddowes	Michelle Katz	Jacki Ochs & Jan Kroeze	Ali Marsh
Renee Edelman	James Kern & Deborah Kern	Paul & Maria Onderdonk	Jane Bolster & Steve Wertimer
David & Chrysti Eigenberg	Steven Klinsky	Sascha Paladino	Jenny Wiener & Jon Steingart
Ned Eisenberg & Patricia Maguire	Mary Kong	Elizabeth Peters	Michael & Zena Wiener
Nora Ephron	Judy Kuhn & David Schwab	Peter & Ana Rosa Phillips	Donald Windham
Wendy Ettinger & Derek McLane	Liza Lerner	Susan Ochs Phillips	Frank Wood
Peter Jay Fernandez & Denise Burse	Ilana Levine & Dominic Fumusa	Katharyn Pinder	Joanne Woodward &
Martin Fetner & William Coury	Joshua Lewis & Sarah Kay	Jeremy & Paulette Posner	Paul Newman
Liz Fillo	Anna Li	Peter & Helen Randolph	Bill Wrubel & Jennifer Crittenden
David Frankel	Katherine Lumb	Paul Reale & Barbara McCrane	Patricia Xenos
Richard Frankel & Kathleen Clark	John Lyons	Willie Reale & Jenny Gersten	Jeffrey & Janine Yass
Alison Fraser & Nat Magee	Grace Lyu-Volckhausen	Theresa Rebeck & Jess Lynn	James & Mary Lin Yoshimura
Frank Frattaroli	Greg MacPherson &	Lise Rehwaldt & Mark Roberts	Elisa Zuritsky & Jordan Barowitz

The 52nd Street Project presents the  
Fall 2004 Playback Show

# Nothing Up My Sleeve: *The Deceptive Plays*

**THE  
AXIS THEATRE  
AT AXIS COMPANY**

*1 Sheridan Square,  
New York, NY*



*Fri., Oct. 22  
at 7:30 p.m.  
Sat., Oct. 23  
at 3:00 p.m.  
and 7:30 p.m.  
Sun., Oct. 24  
at 3:00 p.m.*

# Nothing Up My Sleeve:

*The Deceptive Plays*

THE FALL 2004  
PLAYBACK SHOW  
OCT. 22-24  
AT THE AXIS THEATRE

### The 52nd Street Project Staff:

Gus Rogerson, Artistic Director  
Carol Ochs, Executive Director  
John Sheehy, Director of Development and Marketing  
Megan Sandberg-Zakian, Associate Artistic Director  
George "X-Acto" Babiak, Production Manager  
Liz Bell, Director of Education  
Diana Rojas, Executive Assistant  
Mayleen Cancel, Education Assistant  
Chris Ceraso, Teen Dean  
Iris A. Brown, Graphic Designer  
Solangee Acosta and Amelia Whitney, Receptionists  
Intern: Mara Grunbaum



### Production Staff:

**Composer:** Loren Toolajian  
**Vocal Coach:** Kari Riely  
**Set Designer:** Kevin Joseph Roach  
**Lighting Designer:** Greg MacPherson  
**Costume Designer:** Naomi Wolff  
**Sound Designer:** Maury Schott  
**Stage Manager:** Katie Ahern  
**"Sleeve" Illustration:** Stephanie Bast  
**Prop Design Team:** George Babiak, Heather Carnduff, Galya Diment, Mara Grunbaum, Karen Munkel, Lee Rosen, Amy Schiff, John Sheehy, Rachel Stephens

### Furniture Crew:

Kayelani Silva and Sarah Petersiel

### Prop Crew:

Jennifer Ramirez and Mara Grunbaum

### Load-in and Light Hang Crew:

Lee Briggs, Melissa Jones, Christopher Randolph, Maury Schott, Rachel Stephens, Tim Thomas, Charlie Tocantins

### House Managers:

Karin Schall, Liz Bell, Mary Pat Walsh

### Chef:

The Incredible Liz Bell

The Playback Program is made possible with public funds from The New York State Council on the Arts, a state agency; and the New York City Department of Cultural Affairs. The 52nd Street Project is supported by funds from the National Endowment for the Arts and the Department of Youth and Community Development. The Project is member of ART/NY and a participant in the New Generations Program, funded by Doris Duke Charitable Foundation/The Andrew W. Mellon Foundation and administered by Theatre Communications Group, the national organization for the American Theater.



## COOL STUFF ON SALE!

Flyer Bars .....\$2.00, \$1.50 & \$1.00

*Shel Silverstein's "Fivey and Twoey" logo gear:*

Project Sweatshirts .....\$20.00  
Project Long Sleeve T-Shirts .....\$15.00  
Project Short Sleeve T-Shirts .....\$12.00  
Project Caps .....\$15.00  
Project Mugs .....\$5.00  
Project Spiral Notebooks (NEW!) .....\$5.00  
Project Pencil 3-pack .....\$1.00

Thank you for coming to **NOTHING UP MY SLEEVE**. If you are not on our mailing list (or if your address has changed), please fill out this form and give it to us on your way out or mail it to the address below. We would also like to know if you are interested in becoming a volunteer. We need help in **all areas**, so be sure to fill out the entire form.

### PLEASE ADD ME TO YOUR MAILING LIST:

OCT 2004

NAME: \_\_\_\_\_

ADDRESS: \_\_\_\_\_

\_\_\_\_\_ ZIP \_\_\_\_\_

HOME PHONE: \_\_\_\_\_

DAYTIME PHONE: \_\_\_\_\_

E-MAIL ADDRESS: \_\_\_\_\_

MY OCCUPATION: \_\_\_\_\_

MY HOBBIES: \_\_\_\_\_

### YES, I WOULD LIKE TO BE OF HELP. I CAN:

- |   |   |  |
|---|---|--|
| <input type="checkbox"/> Help load in and out for shows | <input type="checkbox"/> Draw and/or paint  | <input type="checkbox"/> Help kids with homework |
| <input type="checkbox"/> Hang lights                    | <input type="checkbox"/> Help with mailings | <input type="checkbox"/> Teach kids a skill      |
| <input type="checkbox"/> Work on a backstage crew       | <input type="checkbox"/> Do office work     | <input type="checkbox"/> Be a chef at an event   |
| <input type="checkbox"/> Do graphic design              | <input type="checkbox"/> Design sound       | <input type="checkbox"/> Design and sew costumes |
| <input type="checkbox"/> Other (please specify) _____   |   |  |

### MY SCHEDULE IS:

- Very flexible. I'm often available during weekdays.  
 Somewhat flexible. I can help on the occasional morning or afternoon during the week.  
 Not very flexible at all, but I've got some free time on evenings and weekends.

If you would like to mail this (and you're always welcome to enclose a tax-deductible contribution), you can send it to: **The 52nd Street Project**, 500 West 52nd St., New York, NY 10019. Or fax it to (212) 333-5598.

## Don't Miss Our Upcoming Shows!



December 10-12  
Stage 36  
312 W. 36th St.  
3rd Floor

In September, 10 kids brand-new to the Project began a Playmaking class taught by Playmaking Director Megan Sandberg-Zakian. Come and see their final plays performed by adult professional actors.

# AND WE'RE BACK!

THE RETURN OF THE  
TWO-ON-TWOS  
JANUARY 28-30  
AT THE WOMEN'S INTERART ANNEX

The 52nd Street Project is a non-profit organization that brings children from the Hell's Kitchen neighborhood together with professional theater artists to create original theater. **NOTHING UP MY SLEEVE** is a production of our **Playback** program, in which kid actor/playwrights wrote plays that were then "answered" by adult actor/playwright partners who write their own plays. We took the whole menagerie up to the idyllic hamlet of Franklin, NY over the Columbus Day weekend to rehearse the shows. In the final production, which you see here tonight, the partners perform both plays back-to-back. All of the kids involved are veterans of the Playmaking classes which were adapted for the Project by Daniel Judah Sklar from his book *Playmaking: Children Writing and Performing Their Own Plays*.

### The 52nd Street Project Board of Directors

Ben Barenholtz  
Lisa Benavides  
Rachel Chanoff  
Cathy Dantchik  
Wendy Ettinger,  
*chair emeritus*  
Louis P. Friedman  
Stephen Graham, *chair*  
Larry Jones  
James McDaniel  
Frances McDormand  
Noël Mihalow  
Patricia M. Murphy, Esq.

Carol Ochs  
Willie Reale,  
*founder*  
Gus Rogerson  
Shirley Rumierk,  
*alumni member*  
José Soto, Jr.,  
*alumni member*  
Pamala Tyson  
Laura Valeroso  
Wendy vanden Heuvel  
John A. Vassilaros  
Jenny Wiener

### Special Thanks

We're extremely grateful to **Gene, Carol, and Carmela Marner; Tom Duerdon** and **Xena Sheehan**, the **Rich** family and all the folks in Franklin, NY for being such gracious hosts on the weekend away. **Ed Vassallo** gets a special foam-core Croix de Guerre for arranging the entire expedition.

### In-Kind Contributions

Randy, Jeff, Brian, Jared and the AXIS Theatre Company; The Murphy Law Office; Benefit Cosmetics; Iris A. Brown; Bourjois Paris; Bumble and bumble; Ron Kastner and Capital Printing; Kenneth Cole Productions; Noggin; The Printing Store; Scholastic, Inc.; Diageo Chateau & Estate Wines; Entertainment Weekly; Lucky Magazine; Microtouch/Finishing Touch; Molten Brown; MOP Cosmetics; Newman's Own; Pharma Print/Omni Graphics; Sesame Workshop; Wendy Stuhlberg; Terax America; John A. Vassilaros; Watkins, Inc.; Mayor's Office of Film & Television; Boylan's Bottling Co.; David Sneddon & Fairway Market; Lorraine Tobias & Imaginary Studios; Jive Records, part of Zomba Music Group; and Prime Films.



## Nothing Up My Sleeve: The Deceptive Plays - Act I

All original music composed by Loren Toolajian

### Uncertainty

By Skye Blu Welsh, age 13. Dramaturg/Director: Danny Goldstein.

### B.P.H.S. Revisited

Written and directed by Danny Goldstein.

Drew .....Skye Blu Welsh  
James .....Danny Goldstein  
Drew's Friend .....Kaylelani Silva

*"Like You-Like You"* lyrics by Skye Blu Welsh.

### I.I.: Incredible Intelligence

By Octavia Rodriguez, age 12. Dramaturg/Director: Megan Sandberg-Zakian.

### O.I.: Opinionated Intelligence

Written and directed by Megan Sandberg-Zakian.

Robot .....Octavia Rodriguez  
Evil Rose/Dr. Smile .....Megan Sandberg-Zakian  
Voice of operator .....Sarah Petersiel  
Mailman .....George Babiak  
Storekeeper .....Jennifer Ramirez

*"Hate to Sing"* lyrics by Megan Sandberg-Zakian.

### Da Secret

By Amanda Santos, age 13. Dramaturg: Jolie Tong. Director: Malinda Walford.

### Da Lesson

Written by Jolie Tong, directed by Malinda Walford.

Irise/Bernice the Bright .....Amanda Santos  
Bonquisha/Queen Ernestine .....Malinda Walford  
Servant .....Sarah Petersiel

*"Perky and Pink"* lyrics by Amanda Santos. *"Lesson Learned"* lyrics by Jolie Tong.

### Sandy Dream

By Kimani Lewis-Ashley, age 14. Dramaturg/Director: Jed Clarke.

### Life Without Failure

 Written and Directed by Jed Clarke.

Peter .....Kimani Lewis-Ashley  
Hudson IV .....Jed Clarke  
Jack .....George Babiak  
Newscaster .....Sarah Petersiel

*"Feeling Swell"* lyrics by Kimani Lewis-Ashley, *"Failure"* lyrics by Jed Clarke.

👉 **Intermission!** 👈

## Nothing Up My Sleeve: The Deceptive Plays - Act II

### When Wendy Meets Will

By Isayah Muller, age 12. Dramaturg/Director: John Sheehy.

### Who's Your Daddy

 Written and directed by John Sheehy.

Sheriff Wendy MacDonalds .....Isayah Muller  
Pirate Will Abominable .....John Sheehy

*"Your Father Is Insane"* lyrics by Isayah Muller

### Love and Hate

By Britney Castro, age 14. Directed by Abigail Lopez. Dramaturg: Liz Bell.

### Sister, Schizophrenia

Written by Liz Bell. Directed by Abigail Lopez.

Aqua Paradise .....Britney Castro  
Liberty Paradise .....Abigail Lopez  
Friends and runway models .....The Crew  
Jennifer .....Sarah Petersiel  
Rude Backstage Dude .....George Babiak

*"I Need My Liberty"* lyrics by Liz Bell

### My Friend is Not in the Yearbook

By Christopher Ramirez, age 13. Dramaturg/Director: Erin Quinn Purcell.

### Lovelorn Jack and the Enchanting Violin:

### An Operetta in Three Acts

Written and directed by Erin Quinn Purcell.

Jack .....Christopher Ramirez  
Carla/The Evil Witch .....Erin Quinn Purcell  
Cool Kids .....Gus Rogerson and George Babiak  
Cigarette Girl .....Kayelani Silva

*"Carla's Song"* lyrics by Christopher Ramirez, *"I Love This Violin I & II"* lyrics by Erin Quinn Purcell.



The 52nd Street Project gratefully acknowledges the support of the following foundations and corporations: American Media; Barker Welfare Foundation; Bloomberg; Capital Research Company; Carnegie Corporation of New York; CBS; Citigroup; Consolidated Edison; Comedy Central; The Dramatists Guild Fund; Dramatists Play Service; The Max & Victoria Dreyfus Foundation Inc.; Eleanor, Adam & Mel Dubin Foundation; Entertainment Weekly; The Henlopen Foundation; The Hennessy Foundation; HBO; Holland Lodge Foundation, Inc.; The Horace W. Goldsmith Foundation; Hurlbut Family Charitable Lead Trust; JKW Foundation; Betty E. & George B. Kaiser Foundation; Lloyds TSB Bank plc; Lucille Lortel Foundation; James A. Macdonald Foundation; MadHouse, Inc.; Ann M. Martin Foundation; Mellon Equity Associated, LLP; The New World Foundation; The New York Times Company Foundation; Newman's Own; Armstrong Nickoll Family Foundation; Noggin; Norcross Wildlife Foundation, Inc.; The Fox & Leslie R. Samuels Foundation; Sesame Workshop; Stranahan Foundation; The Surdna Foundation; Theatre Communications Group, Inc.; The Vervane Foundation; John A. Vassilaros & Son, Inc; Yorke Construction Corporation; Felix Zarembo & Co. Inc. In addition the following individuals made gifts of over \$200 to The 52nd Street Project this year (list is current as of 6/30/04):

Robert Abrams & Cynthia Vance	Louis & Patrice Friedman	Jane Perlmutter	David & Anita Rogerson
Cecilia Arana-Grant & Kevin Grant	Janeane Garofalo	Doda Manalansan	Daryl Roth
Adam Leitman Bailey	Rose Gasner & Larry Chertoff	Paul & Lauren Mandell	Martha Roth & Bill Irwin
Ben Barenholtz	Alexandra Gersten &	Sonia Manzano &	Steve Sabba
Jessica Bauman	John Vassilaros	Richard Reagan	Arnold & Agnes Sametz
Laurie Becker & Rick Sweren	Cora Cahan & Bernard Gersten	Donald Margulies & Lynn Street	Laura Sametz & Anton Fig
Meredith Beeuwkes	Nancy Giles	Gene & Mary Ann McCoy	Karin & Tom Schall
Lisa Benavides & Tim Nelson	Lloyd & Kitty Gilmour	Paul McCrane & Dana Kellin	Maury Schott
Gavin Berger & Craig Berggren	Judy Goldman & Michael Pillingier	Fran McDormand & Joel Coen	Lauren Seikaly & Michael Huber
Alexander & Elizabeth Bernstein	George & Amy Goldstein	Andrew McKeon	Jeffrey Seller & Joshua Lehrer
Jeanette & Samuel Black	Larry & Carol Goldstein	Rick Meese & Dan Lori	Mitchell Semel & Colleen Carroll
Lewis Black	Stephen & Cathy Graham	Danny Meisner	Aaron & Elaine Shapiro
Tessa Blake	Connie Grappo & Lee Wilkof	Josie Merck & Jim Stevenson	Pam Shaw & Victor Syrmis
Buzz Bovshow	Emily Grishman & Susan Sampliner	Brian Mertes	Seth Shepsle
Jon Brielle	Bruce Grossberg & Laura Rovinsky	Audrey & Danny Meyer	Peter Shinoda
Kathy Briggs	Lisa Gugenheim	Judy Minor	Meg Simon
Becky Browder & Ted Neustadt	Alan Halperin & Wendy Halperin	Emily & John Morgan	Landon Slane
Deborah Brown	Jane & Jonathan Heine	Mala & Sham Mosher	Jeff Stafford
Susan Bruce & Peter Hedges	Peter Herdrich & Karen Trott	Walter Mosley	John Steber & Robert Shaffron
Kate Burton & Michael Ritchie	Amy Hertzig	Michelle Mulitz & Morty Gudelsky	Jean Stein
Linda & Arthur Carter	William Holtzman &	Suzen Murakoshi & Mark Temme	R.L. Stine & Jane Stine
Constance Casey	S. Sylvia Shepard	Richard Murawczyk	Susanna Styron & Darrell Larson
Alfred C. Cerullo III	Katy Homans & Patterson Sims	& Laura Murawczyk	Daniel Swee
Rachel Chanoff	Sarah Horowitz & David Venarde	Patricia M. Murphy, Esq.	Timothy Thomas
Lieta Heslen-Cohen & Richard Cohn	Sy Jacobs	& Adam Spilka	Adriana & Tim Stephenson
Billy Crudup	Donna & Thomas Jaycox	Frank Napolitano	Laura Valeroso & David Seidman
Tom Cruise	Amanda Johns	Steven Neiditz & Leslie Neiditz	Wendy vanden Heuvel &
Arthur Dantchik	Andrea Johnson	Don & Sara Nelson	Brad Coley
Cathy Dantchik	Kristen Johnston	Randy & Rona Nelson	Susan Vitucci
Leslie Dantchik	Larry & Mary Jones	Clea Newman	Mary Pat Walsh
Peter & Judith Dawkins	Aram Kailian & Eli Pariser	Edward Norton	Brenda Wehle & John C. Lynch
Alex Draper & Lorraine Tobias	Sheryl Kaller	Kevin O'Rourke & Edith Thurber	Randall Weisenburger
Richard & Rebecca Dresser	Cindy Kaplan	Carol Ochs & Bruce MacVittie	Sally & Lenny Weiss
Christopher & Karen Eddowes	Michelle Katz	Jacki Ochs & Jan Kroeze	Ali Marsh
Renee Edelman	James Kern & Deborah Kern	Paul & Maria Onderdonk	Jane Bolster & Steve Wertimer
David & Chrysti Eigenberg	Steven Klinsky	Sascha Paladino	Jenny Wiener & Jon Steingart
Ned Eisenberg & Patricia Maguire	Mary Kong	Elizabeth Peters	Michael & Zena Wiener
Nora Ephron	Judy Kuhn & David Schwab	Peter & Ana Rosa Phillips	Donald Windham
Wendy Ettinger & Derek McLane	Liza Lerner	Susan Ochs Phillips	Frank Wood
Peter Jay Fernandez & Denise Burse	Ilana Levine & Dominic Fumusa	Katharyn Pinder	Joanne Woodward &
Martin Fetner & William Coury	Joshua Lewis & Sarah Kay	Jeremy & Paulette Posner	Paul Newman
Liz Fillo	Anna Li	Peter & Helen Randolph	Bill Wrubel & Jennifer Crittenden
David Frankel	Katherine Lumb	Paul Reale & Barbara McCrane	Patricia Xenos
Richard Frankel & Kathleen Clark	John Lyons	Willie Reale & Jenny Gersten	Jeffrey & Janine Yass
Alison Fraser & Nat Magee	Grace Lyu-Volckhausen	Theresa Rebeck & Jess Lynn	James & Mary Lin Yoshimura
Frank Frattaroli	Greg MacPherson &	Lise Rehwaldt & Mark Roberts	Elisa Zuritsky & Jordan Barowitz

The 52nd Street Project Presents

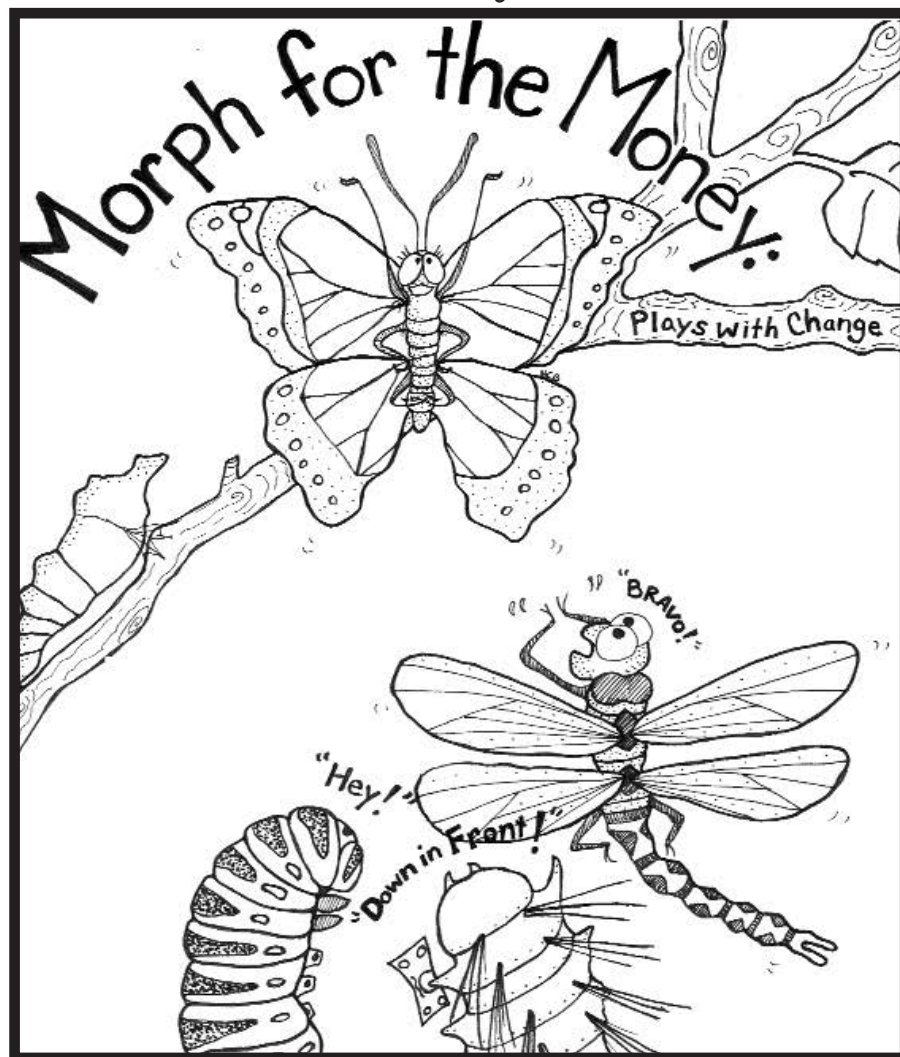

## The Kripplebush Playmaking Series - Fall 2004

Fri., Dec. 10 at 7:30 p.m.,

Sat., Dec. 11 at 3:00 p.m. and 7:30 p.m.

and Sun., Dec. 12 at 3:00 p.m.

Stage 36, 312 West 36th St.

# Morph for the Money

The Kripplebush Playmaking Plays - Fall 2004 - Dec. 12-14  
Stage 36, 312 W. 36th St.

## The 52nd Street Project Staff:

Gus Rogerson, Artistic Director  
Carol Ochs, Executive Director  
John Sheehy, Director of Development and Marketing  
Megan Sandberg-Zakian, Associate Artistic Director  
George "X-Acto" Babiak, Production Manager  
Liz Bell, Director of Education  
Diana Rojas, Executive Assistant  
Chris Ceraso, Teen Dean  
Mayleen Cancel, Education Assistant  
Iris A. Brown, Graphic Designer  
Solangee Acosta and Amelia Whitney, Receptionists  
Mara Grunbaum, Intern

## Production Staff

**Composer:** Patrick Barnes  
**Set Designer:** Kevin Joseph Roach  
**Lighting Designer:**  
Greg MacPherson  
**Countess of Costumes:**  
Crystal Thompson  
**Sound Designer:** Maury Schott  
**Stage Manager:** Sarah Wynne  
**Slide Designers:**  
George Babiak, Sandra Barron,  
Chris Bonanos, Todd Levin,  
Katherine Lumb, Mike Sell,  
John Steward, Alberta Testanero  
**"Morph" Illustration:**  
Heather Carnduff-Gobbée  
**Prop Design Team:**  
George Babiak, Heather Carnduff-  
Gobbée, Emmy Grinwis,

Mara Grunbaum, Lee Rosen,  
John Sheehy  
**Furniture Crew:**  
Ephraim Lopez  
and Mordecai Santiago  
**Prop Crew:**  
Mara Grunbaum and Skyebly Welsh  
**Load-in and Light Hang Crew:**  
Moirra MacDonald, Doug Nervik,  
Jamie Smith  
**Playmaking Class Volunteers:**  
Nancy Giles, Maile Holck, Melissa  
Jones, Mario Quesada  
**House Managers:**  
Karin Schall, Mary Pat Walsh,  
Liz Bell  
**Host/Chefs:**  
Joe White and Iris A. Brown

## COOL STUFF ON SALE!

Flyer Bars .....\$2.00, \$1.50 & \$1.00

*Shel Silverstein's "Fivey and Twoey" logo gear:*

Project sweatshirts .....\$20.00  
Project long sleeve t-Shirts .....\$15.00  
Project Caps .....\$15.00  
Project Mugs .....\$5.00  
Project Pencil 3-pack .....\$1.00  
"Sweet Appreciation" CD .....\$25.00

Thank you for coming to **MORPH FOR THE MONEY**. If you are not on our mailing list (or if your address has changed), please fill out this form and give it to us on your way out or mail it to the address below. We would also like to know if you are interested in becoming a volunteer. We need help in **all areas**, so be sure to fill out the entire form.

### PLEASE ADD ME TO YOUR MAILING LIST:

12/04

NAME: \_\_\_\_\_

ADDRESS: \_\_\_\_\_

ZIP \_\_\_\_\_

HOME PHONE: \_\_\_\_\_

DAYTIME PHONE: \_\_\_\_\_

E-MAIL ADDRESS: \_\_\_\_\_

MY OCCUPATION: \_\_\_\_\_

MY HOBBIES: \_\_\_\_\_

### YES, I WOULD LIKE TO BE OF HELP. I CAN:

- |   |   |  |
|---|---|--|
| <input type="checkbox"/> Help load in and out for shows | <input type="checkbox"/> Draw and/or paint  | <input type="checkbox"/> Help kids with homework |
| <input type="checkbox"/> Hang lights                    | <input type="checkbox"/> Help with mailings | <input type="checkbox"/> Teach kids a skill      |
| <input type="checkbox"/> Work on a backstage crew       | <input type="checkbox"/> Do office work     | <input type="checkbox"/> Be a chef at an event   |
| <input type="checkbox"/> Do graphic design              | <input type="checkbox"/> Design sound       | <input type="checkbox"/> Design and sew costumes |
| <input type="checkbox"/> Other (please specify) _____   |   |  |

### MY SCHEDULE IS:

- Very flexible. I'm often available during weekdays.  
 Somewhat flexible. I can help on the occasional morning or afternoon during the week.  
 Not very flexible at all, but I've got some free time on evenings and weekends.

If you would like to mail this (and you're always welcome to enclose a tax-deductible contribution), you can send it to: **The 52nd Street Project**, 500 West 52nd St., New York, NY 10019. Or fax it to (212) 333-5598.



The Playmaking Program is made possible with public funds from The New York State Council on the Arts, a state agency. The 52nd Street Project is a member of Art/NY and a participant in the New Generations Program, funded by Doris Duke Charitable Foundation/The Andrew W. Mellon Foundation and administered by Theatre Communications Group, the national organization for the American Theater.



**Don't Miss Our Upcoming Shows!**

# And We're Back!

## THE RETURN OF THE...

January  
28th,  
29th,  
and 30th  
2005

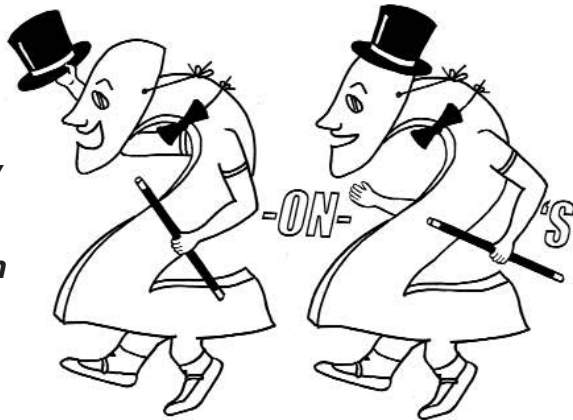

The  
Women's  
Interart  
Annex,  
500 W. 52nd

6 new plays, each with two kids as performers and two adults as writers and directors. We haven't done this in two years!



# What's the Big Idea?

Plays to Think About

The Spring Edition of the  
Project's Playmaking Program  
April 1, 2, and 3 at  
The Calhoun School Theater

If you're enjoying the show tonight, you'll want to take in another set of shows by our next batch of Project newcomers! Call 642-5052 for reservations.

The 52nd Street Project is a non-profit organization that brings children from the Hell's Kitchen neighborhood together with professional theater artists to create original theater. **MORPH FOR THE MONEY** is a production of our Playmaking program. Young people participate in a nine-week playwriting course taught by Megan Sandberg-Zakian and adapted for the Project by Daniel Judah Sklar from his book *Playmaking: Children Writing and Performing Their Own Plays*. At the end of the course, each child is given two actors, a theme, and a dramaturg/director who guides him or her through the writing of a play during a weekend retreat in the country (Kripplebush, New York, for this show). Tonight's performance is the end result.

### The 52nd Street Project Board of Directors

Ben Barenholtz  
Lisa Benavides  
Rachel Chanoff  
Cathy Dantchik  
Noël Dawkins  
Wendy Ettinger,  
*chair emeritus*  
Louis P. Friedman  
Stephen Graham, *chair*  
Larry Jones  
James McDaniel  
Frances McDormand  
Patricia M. Murphy, Esq.

Carol Ochs  
Willie Reale,  
*founder*  
Gus Rogerson  
Shirley Rumierk,  
*alumni member*  
José Soto, Jr.,  
*alumni member*  
Pamala Tyson  
Laura Valeroso  
Wendy vanden Heuvel  
John A. Vassilaros  
Jenny Wiener

### Special Thanks

We're extremely grateful to **Steve Buscemi** and **Jo Andres**, who graciously allowed us to use their beautiful home in Kripplebush, NY as our base of operations for the writer's retreat. We also owe a mini-van load of gratitude to **Joe White** and **Iris Brown** for cooking some mighty big (and good) meals and lining up all the other host families (who earn thanks as well): **Tim Guinee** and **Daisy Foote**, **Laura Shane Cunningham**, **Mary Louise Wilson**, **Nicole** and **Paul Quinn**, **Deborah Freedman**, **Bill Woods**, and **Charles** and **Naomi Miles**.

### In-Kind Contributions

The Murphy Law Office; Benefit Cosmetics; Iris A. Brown; Bourjois Paris; Bumble and bumble; Ron Kastner and Capital Printing; Kenneth Cole Productions; Noggin; The Printing Store; Scholastic, Inc.; Diageo Chateau & Estate Wines; Entertainment Weekly; Lucky Magazine; Microtouch/Finishing Touch; Molten Brown; MOP Cosmetics; Newman's Own; Pharma Print/Omni Graphics; Sesame Workshop; Wendy Stuhlberg; Terax America; John A. Vassilaros; Watkins, Inc.; Mayor's Office of Film & Television; Boylan's Bottling Co.; David Sneddon & Fairway Market; Lorraine Tobias & Imaginary Studios; Jive Records, part of Zomba Music Group; and Prime Films.

## Morph for the Money - ACT I

All original music composed by Patrick Barnes

### The Life of Malibu and Fabulous Joe

by Amonson Pargas, age 10. Dramaturg/Director: Sascha Paladino  
Costume Designer: Munee Hayes

Malibu .....Kenajuan Bentley  
Fabulous Joe .....Bruce MacVittie  
Security Guy .....Mordecai Santiago

*“The Hip-Hop Classic Rock Music Song”* lyrics by Amonson Pargas

### A Cubic Corzonicon Life

by Azalea Rosario, age 10. Dramaturg/Director: Denise Burse  
Costume Designers: Debbie Lucas and Stephanie Bear

Dace .....Danyon Davis  
Hoggy, a groundhog .....Bryan Gmitter

*“Now We Are Friends”* lyrics by Azalea Rosario

### The Miracle of Music

By Carlos Dume, age 10. Dramaturg/Director: David Eigenberg  
Costume Designers: Scott Coppock and Marit Aagaard

Kate, a microphone .....Ellen Foley  
Phil, an electric guitar .....David Eigenberg  
Mom .....Skyeblu Welsh

*“My Brother and I”* lyrics by Carlos Dume

### The Big, The Small, and the Goofy

by Jason Gil, age 9. Dramaturg/Director: Peter Jay Fernandez  
Costume Designers: Marit Aagaard and Scott Coppock

Great Giant Shark .....Peter Appel  
Short Fuse .....Mario Quesada  
Russian Citizen .....George Babiak

*“What I Could Do”* lyrics by Jason Gil

### Why?

By Catherine Fernandez, age 10. Dramaturg/Director: Jessica Bauman  
Costume Designer: Cathrine Piper

Daisy .....Saidah Arrika Ekulona  
Kelly .....Michelle Pawk  
Mr. Barken .....John Sheehy

*“Change”* lyrics by Catherine Fernandez

☞ **Intermission!** ☞

## Morph for the Money - ACT II

### Trust

by Lilian Moore, age 12. Dramaturg/Director: Maria Goyanes  
Costume Designer: Vicki Jo De Rocker

Sandra Star .....Lucia Brawley  
Mr. Roy Whiskers .....Dion Graham

*“Letting Go”* lyrics by Lilian Moore

### I Wish I Had Something To Do

by Emmett Goodman-Boyd, age 10. Dramaturg/Director: Emmy Grinwis  
Costume Designer: Munee Hayes

Zack .....Christopher Randolph  
Amy .....Florencia Lozano

*“I Have an Idea”* lyrics by Emmett Goodman-Boyd

### The Big Chase

by Lordan Ulloa, age 10. Dramaturg/Director: Charlie Tocantins  
Costume Designer: Vicki Jo De Rocker

Alexis .....Cecilia Arana  
Slimy .....Eddie Cooper

### For All Those Years

by Krystal Vega, age 11. Dramaturg/Director: Liliana Amador  
Costume Designer: Cathrine Piper

Kat Ellen .....Catherine Mueller  
Elisa Ellen .....Maile Holck  
Michael .....Mordecai Santiago

*“Why I Should Be Picked”* and *“Everything I Did for You”* lyrics by Krystal Vega

### Trees and Snow

by Samantha Toro, age 10. Dramaturg/Director: Gus Rogerson  
Costume Designers: Debbie Lucas and Stephanie Bear

Snowy Man .....John Conlee  
Big Tree .....Melissa Jones  
The Tree .....Ephraim Lopez  
Different Tree .....Mara Grunbaum



*A Very  
Happy  
Holiday to all  
Projectiles!*

## The 52nd Street Project Cabaret

### Trees and Snow

by Samantha Toro, age 10. Dramaturg/Director: Gus Rogerson  
Costume Designers: Debbie Lucas and Stephanie Biear

Snowy Man . . . . .John Conlee  
Big Tree . . . . .Melissa Jones

### For All Those Years

by Krystal Vega, age 11.  
Dramaturg/Director: Liliana Amador  
Costume Designer: Cathrine Piper

Kat Ellen . . . . .Catherine Mueller  
Elisa Ellen . . . . .Maile Holck

*"Why I Should Be Picked"* and *"Everything I Did for You"* lyrics  
by Krystal Vega, music by Patrick Barnes

### Two Gents of Whence

Written by Willie Reale & Directed by Victor Rojas  
for Christopher Ramirez, age 14  
Costume Designers: Crystal Thompson and Vicki Jo De Rocker

Spence . . . . .Christopher Ramirez  
Impetigo . . . . .Victor Rojas

*"Heather"* and *"Me"* lyrics by Willie Reale, music by Kim D.  
Sherman

### The Miracle of Music

By Carlos Dume, age 10. Dramaturg/Director: David Eigenberg  
Costume Designers: Scott Coppock and Marit Aagaard

Kate, a microphone . . . . .Ellen Foley  
Phil, an electric guitar . . . . .Maggie Lacey  
Mom . . . . .George Babiak

*"My Brother and I"* lyrics by Carlos Dume

## "Just Kidding" at Symphony Space

### I Wish I had Something to Do

by Emmett Goodman-Boyd, age 10.  
Dramaturg/Director: Emmy Grinwis  
Costume Designer: Muneé Hayes

Zack . . . . .Christopher Randolph  
Amy . . . . .Florencia Lozano

*"I Have an Idea"* lyrics by Emmett Goodman-Boyd, music by  
Patrick Barnes

### Fools Russian

Written & Directed by John Sheehy  
for Jason Peterson Ridge, age 11  
Costume Designer: Bryan Gmitter

Sergei . . . . .John Sheehy  
Alexei . . . . .Jason Peterson Ridge  
Ringmaster . . . . .George Babiak

*"I Can't Hold On"* lyrics by John Sheehy, music by Kim D.  
Sherman

**Stage Manager:** Karen Munkel

**Lighting Designer:** Greg MacPherson

**Music Director:** Patrick Barnes

**Sound operator:** Mara Grunbaum

**Backstage support:** Ephraim Lopez

### The 52nd Street Project Staff

Gus Rogerson, Artistic Director

Carol Ochs, Executive Director

John Sheehy, Director of Development and Marketing

Megan Sandberg-Zakian, Associate Artistic Director

George Babiak, Production Manager

Liz Bell, Director of Education

Diana Rojas, Executive Assistant

Mayleen Cancel, Education Assistant

## **About The 52nd Street Project**

The 52nd Street Project is dedicated to the creation and production of new plays for and by kids between the ages of ten and eighteen who reside in the Hell's Kitchen neighborhood of New York City. The Project does this through unique mentoring programs that match kids with professional (and volunteer!) theater artists.

The Project is about making children proud of themselves. The Project is not about teaching children to act or write plays, although they will learn how to do both. What it is about is giving a kid an experience of success. It is an opportunity to prove that he or she has something of value to offer, something that comes from within that he or she alone possesses, something that cannot be taken away.

The program we present today is a specially selected smorgasbord of plays from the **One-on-Ones**, our summertime series in which kids perform with adults, and our **Playmaking** program, in which kids write original scripts for professional adult actors.

### ***The 52nd Street Project***

500 West 52nd St., #2B, New York, NY 10019

Phone: (212) 333-5252 Fax: (212) 333-5598

For more information about volunteering or our programs,  
call us, visit [www.52project.org](http://www.52project.org), or write to us at [info@52project.org](mailto:info@52project.org)

The 52nd Street Project gratefully acknowledges the support of the following foundations and corporations: American Media; Barker Welfare Foundation; Bloomberg; Blythmour Corporation; Capital Research Company; Carnegie Corporation of New York; CBS, Citigroup; Cityrest LLC; Consolidated Edison; Comedy Central; St. Vincent de Paul Foundation; The Dramatists Guild Fund; Dramatists Play Service; The Max & Victoria Dreyfus Foundation Inc.; Eleanor, Adam & Mel Dubin Foundation; Entertainment Weekly; The Horace W. Goldsmith Foundation; The Henlopen Foundation; The Hennessy Foundation; HBO; Holland Lodge Foundation, Inc.; Hurlbut Family Charitable Lead Trust; JKW Foundation; Betty E. & George B. Kaiser Foundation; Lloyds TSB Bank plc; Lucille Lortel Foundation; James A. Macdonald Foundation; Mad.House, Inc.; Ann M. Martin Foundation; Mellon Equity Associated, LLP; The New World Foundation; The New York Times Company Foundation; Newman's Own; Armstrong Nickoll Family Foundation; Noggin; Norcross Wildlife Foundation, Inc.; The Fan Fox & Leslie R. Samuels Foundation; Sesame Workshop; Stranahan Foundation; The Surdna Foundation; Theatre Communications Group, Inc.; The Vervane Foundation; John A. Vassilaros & Son, Inc; The Wiener Family Foundation; Yorke Construction Corporation; Felix Zarembo & Co. Inc. In addition the following individuals made gifts of over \$200 to The 52nd Street Project this year (list is current as of 1/26/05):

Robert Abrams & Cynthia Vance	Rose Gasner & Larry Chertoff	Sonia Manzano & Richard Reagan	Laura Sametz & Anton Fig
Cecilia Arana-Grant & Kevin Grant	Alexandra Gersten & John Vassilaros	Donald Margulies & Lynn Street	Karin & Tom Schall
Adam Leitman Bailey	Cora Cahan & Bernard Gersten	Gene & Mary Ann McCoy	Maury Schott
Ben Barenholtz	Nancy Giles	Paul McCrane & Dana Kellin	Lauren Seikaly & Michael Huber
Jessica Bauman & Ben Posel	Lloyd & Kitty Gilmour	Fran McDormand & Joel Coen	Jeffrey Seller & Joshua Lehrler
Meredith Beeuwkes	Judy Goldman & Michael Pillingier	Andrew McKeon	Mitchell Semel & Colleen Carroll
Lisa Benavides & Tim Nelson	George & Amy Goldstein	Rick Meese & Dan Lori	Aaron & Elaine Shapiro
Gavin Berger & Craig Berggren	Larry & Carol Goldstein	Danny Meisner	Pam Shaw & Victor Szymis
Alexander & Elizabeth Bernstein	James & Virginia Graham	Josie Merck & Jim Stevenson	Seth Shepsle
Jeanette & Samuel Black	Stephen & Cathy Graham	Brian Mertes	Peter Shinoda
Lewis Black	Connie Grappo & Lee Wilkof	Audrey & Danny Meyer	Mitchell Silverman
Tessa Blake	Emily Grishman & Susan Sampliner	Judy Minor	Meg Simon
Buzz Bovshow	Bruce Grossberg & Laura Rovinsky	Emily & John Morgan	Landon Slane
Jon Brielle	Lisa Gugenheim	Mala & Sham Mosher	Jeff Stafford
Kathy Briggs	Alan Halperin & Wendy Halperin	Walter Mosley	John Steber & Robert Shaffron
Becky Browder & Ted Neustadt	Jane & Jonathan Heine	Keith & Judy Muhleman	Jean Stein
Deborah Brown	Peter Herdrich & Karen Trott	Michelle Multz & Morty Gudelsky	R.L. Stine & Jane Stine
Susan Bruce & Peter Hedges	Amy Herzig	Suzen Murakoshi & Mark Temme	Susanna Styron & Darrell Larson
Kate Burton & Michael Ritchie	William Holtzman & S. Sylvia Shepard	Richard Murawczyk & Laura Murawczyk	Daniel Swee
Linda & Arthur Carter	Katy Homans & Patterson Sims	Patricia M. Murphy, Esq. & Adam Spilka	Timothy Thomas
Constance Casey	Sarah Horowitz & David Venarde	Frank Napolitano	Adriana & Tim Stephenson
Alfred C. Cerullo III	Sy Jacobs	Steven Neiditz & Leslie Neiditz	Richard Sweren
Rachel Chanoff	Donna & Thomas Jaycox	Don & Sara Nelson	Liz Tuccillo
Lietla Heslen-Cohen & Richard Cohn	Amanda Johns	Randy & Rona Nelson	Laura Valeroso & David Seidman
Billy Crudup	Andrea Johnson	Clea Newman	Wendy vanden Heuvel & Brad Coley
Tom Cruise	Kristen Johnston	Edward Norton	Ed Vassallo
John Dagenhard	Larry & Mary Jones	Kevin O'Rourke & Edith Thurber	Susan Vitucci
Arthur Dantchik	Aram Kailian & Eli Pariser	Carol Ochs & Bruce MacVittie	Mary Pat Walsh
Cathy Dantchik	Sheryl Kaller	Jacki Ochs & Jan Kroeze	Sam & Lynn Waterston
Leslie Dantchik	Cindy Kaplan	Paul & Maria Onderdonk	Brenda Wehle & John C. Lynch
Peter & Judith Dawkins	Michelle Katz	Sascha Paladino	Randall Weisenburger
Alex Draper & Lorraine Tobias	James Kern & Deborah Kern	Elizabeth Peters	Sally & Lenny Weiss
Richard & Rebecca Dresser	Steven Klinsky	Peter & Ana Rosa Phillips	Ali Marsh
Christopher & Karen Eddowes	Mary Kong	Susan Ochs Phillips	Jane Bolster & Steve Wertimer
Renee Edelman	Judy Kuhn & David Schwab	Katharyn Pinder	Jenny Wiener & Jon Steingart
David & Chrysti Eigenberg	Kate Lear & Jonathan LaPook	Jeremy & Paulette Posner	Michael & Zena Wiener
Ned Eisenberg & Patricia Maguire	Liza Lerner	Peter & Helen Randolph	Donald Windham
Nora Ephron	Ilana Levine & Dominic Fumusa	Paul Reale & Barbara McCrane	Frank Wood
Heidi Ettinger	Joshua Lewis & Sarah Kay	Willie Reale & Jenny Gersten	Joanne Woodward & Paul Newman
Wendy Ettinger & Derek McLane	Anna Li	Theresa Rebeck & Jess Lynn	Bill Wrubel & Jennifer Crittenden
Peter Jay Fernandez & Denise Borse	Katherine Lumb	Lise Rehwaldt & Mark Roberts	Patricia Xenos
Martin Fetner & William Coury	John Lyons	David & Anita Rogerson	Jeffrey & Janine Yass
Liz Fillo	Grace Lyu-Volkhausen	Daryl Roth	Mei Yueh Yen
David Frankel	Greg MacPherson & Jane Perlmutter	Martha Roth & Bill Irwin	James & Mary Lin Yoshimura
Richard Frankel & Kathleen Clark	Doda Manalansan	Steve Sabba	Bill Zarembo
Alison Fraser & Nat Magee	Paul & Lauren Mandell	Arnold & Agnes Sametz	Elisa Zuritsky & Jordan Barowitz
Frank Frattaroli			
Louis & Patrice Friedman			
Janeane Garofalo			

The 52nd Street Project Presents

# ...And We're Back!

## THE RETURN OF THE

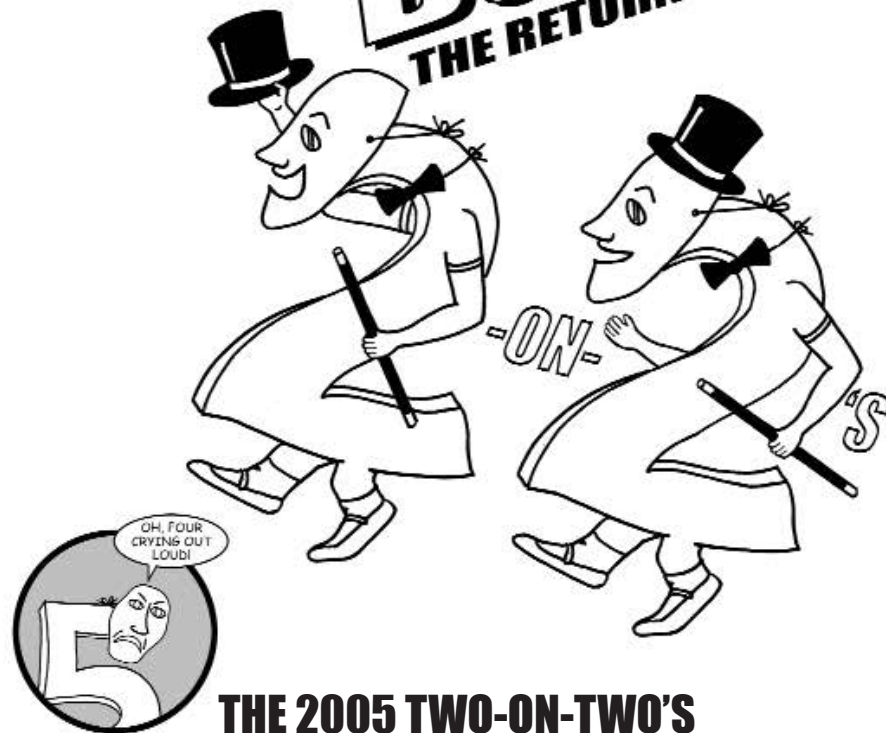

### THE 2005 TWO-ON-TWO'S

Friday, January 28 at 7:30 p.m.

Saturday, January 29 at 3:00 & 7:30 p.m.

Sunday, January 30 at 3:00 p.m.

### THE WOMEN'S INTERART ANNEX

500 W. 52nd St., #2A



# AND WE'RE BACK...

The Return of the Two-on-Two's - January 28-30, 2005  
The Women's Interart Annex

## The 52nd Street Project Staff:

Gus Rogerson, Artistic Director  
Carol Ochs, Executive Director  
John Sheehy, Director of Development and Marketing  
Megan Sandberg-Zakian, Associate Artistic Director  
George "X-Acto" Babiak, Production Manager  
Liz Bell, Director of Education  
Diana Rojas, Executive Assistant  
Mayleen Cancel, Education Assistant  
Chris Ceraso, Teen Dean  
Iris A. Brown, Graphic Designer  
Solangee Acosta and Amelia Whitney, Receptionists  
Rebecca Greig, Intern

## Production Staff

**Composer:** Joel Derfner

**Musical Director:** Doug Nervik

**Set Designer:** Kevin Joseph Roach

**Lighting Designer:**

Greg MacPherson

**Costume Designer:** Lora LaVon

**Sound Designer:** Vanessa Valdes

**Stage Manager:** Erica Schmidt

**Slide Designers:**

George Babiak, Sandra Barron,  
Chris Bonanos, Todd Levin,  
Katherine Lumb, Mike Sell,  
John Steward, Alberta Testanero

**Prop Design Team:**

George Babiak, Heather Carnduff-  
Gobbée, Rebecca Greig

**Furniture Crew:**

Charlie Tocantins and  
Stephanie Vamvoukakis

**Prop Crew:**

Rebecca Greig and Octavia Rodriguez

**Load-in and Light Hang Crew:**

Michael Coghlan, Nedra Gallegos,  
Yana Landowne, Doug Nervik,  
Anne O'Sullivan

**House Managers:**

Karin Schall, Mary Pat Walsh,  
Liz Bell

**Hosts:**

Fisher Stevens, Lili Taylor,  
Maria Tucci and Robert Gottlieb

# COOL STUFF ON SALE!

Flyer Bars .....\$2.00, \$1.50 & \$1.00

*Shel Silverstein's "Fivey and Twoey" logo gear:*

Project sweatshirts .....\$20.00

Project long sleeve t-Shirts .....\$15.00

Project Caps .....\$15.00

Project Mugs .....\$5.00

Project Pencil 3-pack .....\$1.00

Project Notebooks .....\$5.00

Thank you for coming to **AND WE'RE BACK**. If you are not on our mailing list (or if your address has changed), please fill out this form and give it to us on your way out or mail it to the address below. We would also like to know if you are interested in becoming a volunteer. We need help in **all areas**, so be sure to fill out the entire form.

**PLEASE ADD ME TO YOUR MAILING LIST:**

01/05

NAME: \_\_\_\_\_

ADDRESS: \_\_\_\_\_

ZIP \_\_\_\_\_

HOME PHONE: \_\_\_\_\_

DAYTIME PHONE: \_\_\_\_\_

E-MAIL ADDRESS: \_\_\_\_\_

MY OCCUPATION: \_\_\_\_\_

MY HOBBIES: \_\_\_\_\_

**YES, I WOULD LIKE TO BE OF HELP. I CAN:**

- |   |   |  |
|---|---|--|
| <input type="checkbox"/> Help load in and out for shows | <input type="checkbox"/> Draw and/or paint  | <input type="checkbox"/> Help kids with homework |
| <input type="checkbox"/> Hang lights                    | <input type="checkbox"/> Help with mailings | <input type="checkbox"/> Teach kids a skill      |
| <input type="checkbox"/> Work on a backstage crew       | <input type="checkbox"/> Do office work     | <input type="checkbox"/> Be a chef at an event   |
| <input type="checkbox"/> Do graphic design              | <input type="checkbox"/> Design sound       | <input type="checkbox"/> Design and sew costumes |
| <input type="checkbox"/> Other (please specify) _____   |   |  |

**MY SCHEDULE IS:**

- Very flexible. I'm often available during weekdays.  
 Somewhat flexible. I can help on the occasional morning or afternoon during the week.  
 Not very flexible at all, but I've got some free time on evenings and weekends.

If you would like to mail this (and you're always welcome to enclose a tax-deductible contribution), you can send it to: **The 52nd Street Project**, 500 West 52nd St., New York, NY 10019. Or fax it to (212) 333-5598.

State of the Arts



NYSOCA

The Two-on-Two's Program is made possible with public funds from The New York State Council on the Arts, a state agency. The 52nd Street Project is a member of Art/NY and a participant in the New Generations Program, funded by Doris Duke Charitable Foundation/The Andrew W. Mellon Foundation and administered by Theatre Communications Group, the national organization for the American Theater.



## Don't Miss Our Upcoming Shows!

# M+M: THE REMIX

THE 52ND STREET PROJECT  
TEEN ENSEMBLE  
PRESENTS SCENES INSPIRED BY  
WILLIAM SHAKESPEARE'S  
**MEASURE FOR MEASURE**  
FOR MATURE AUDIENCES ONLY!  
MARCH 3 & 4  
IN THIS VERY SPACE

## What's the Big Idea?

Plays to Think About

The Spring Playmaking Series

April 1-3 at The Calhoun School Theater

A brand-new set of shows by the next batch of brand-new  
Projectiles! Call 212/642-5052 for reservations.



Hank Azaria and Oliver Platt invite you to  
Save the Date, and possibly the World at...

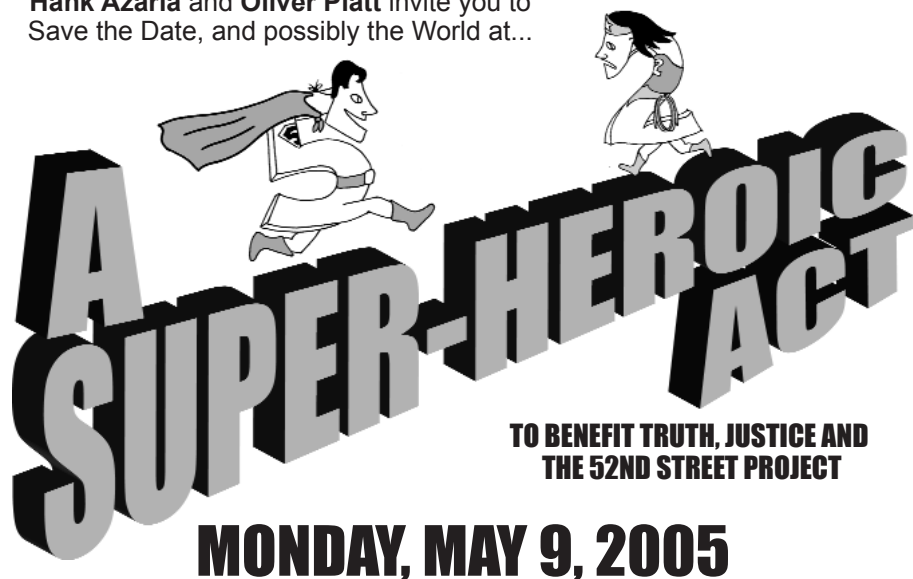

**MONDAY, MAY 9, 2005**

For reservations or info call John "The Thing" Sheehy @ 212/333-5252

The 52nd Street Project is a non-profit organization that brings children from the Hell's Kitchen neighborhood together with professional theater artists to create original theater. **And We're Back...** is a production of our Two-on-Two's program, in which an adult playwright crafts a piece for a pair of Project kids to perform. Another adult directs the kids for a month that includes an intensive three-day weekend in Dutchess County, New York. Tonight's performance is the final result.

### The 52nd Street Project Board of Directors

Ben Barenholtz  
Lisa Benavides  
Rachel Chanoff  
Cathy Dantchik  
Noël Dawkins  
Wendy Ettinger,  
*chair emeritus*  
Louis P. Friedman  
Stephen Graham, *chair*  
Larry Jones  
James McDaniel  
Frances McDormand  
Patricia M. Murphy, Esq.

Carol Ochs  
Willie Reale,  
*founder*  
Gus Rogerson  
Shirley Rumierk,  
*alumni member*  
José Soto, Jr.,  
*alumni member*  
Pamala Tyson  
Laura Valeroso  
Wendy vanden Heuvel  
John A. Vassilaros  
Jenny Wiener

### Special Thanks

We're grateful to **Margot, Ronnie, Josh**, and the rest of the staff at **Women's Interart Annex** for making their extremely convenient space available to us. We also owe big-time thanks to **Maria Tucci** and **Robert Gottlieb, Lili Taylor**, and **Fisher Stevens**, all of whom graciously allowed us to use their upstate homes for three tumultuous and fun-filled days. Our gratitude also goes to Super Project Pal **Ron Fiorina** of **Boylan Bottling Co.**, **Mary Moore & D'Agostino's Supermarkets**, and board member **John A. Vassilaros** (a.k.a. Johnny Coffeeshopolis) for contributing our intermission refreshments. We are also grateful for the extraordinary amount of snow this year.

### In-Kind Contributions

The Murphy Law Office; Benefit Cosmetics; Iris A. Brown; Bourjois Paris; Bumble and bumble; Ron Kastner and Capital Printing; Kenneth Cole Productions; Noggin; The Printing Store; Scholastic, Inc.; Diageo Chateau & Estate Wines; Entertainment Weekly; Lucky Magazine; Microtouch/Finishing Touch; Molten Brown; MOP Cosmetics; Newman's Own; Pharma Print/Omni Graphics; Sesame Workshop; Wendy Stuhlberg; Terax America; John A. Vassilaros; Watkins, Inc.; Mayor's Office of Film & Television; Boylan's Bottling Co.; David Sneddon & Fairway Market; Lorraine Tobias & Imaginary Studios; Jive Records, part of Zomba Music Group; and Prime Films.

## And We're Back - ACT I

All original music composed by Joel Derfner  
and played by Doug Nervik

### David and Manny

By Michael Bernard. Directed by Michael Baron.

Manny . . . . .Alex Tomas  
David . . . . .Eddie Cuevas  
Announcer . . . . .Charlie Tocantins

“Ladies” lyrics by Michael Bernard.

### More Potatoes, More

By Madeleine George. Directed by Kim Sykes.

Rosalie . . . . .Katie Grullon  
Renee . . . . .Kamila Jacobs

“More Potatoes, More” lyrics by Madeleine George.

### The Giant and the Fairy

By Keira Naughton. Directed by Ed Vassallo.

Peaseblossom . . . . .Nicole Fargardo  
Goliath . . . . .Zebulun Santiago  
Forest Policeman . . . . .Charlie Tocantins

“Schadenfreude” and “We Killed a Freakin’ Dragon” lyrics by  
Keira Naughton.

☞ **Intermission!** ☜

Root Beer Floats, Coffee,  
and Flyer Bars in the lobby!

## And We're Back - ACT II

### Don and Dean

By Josh Lewis. Directed by Drew Cortese.

Dean . . . . .Mark Gamero  
Don . . . . .Michael Velez  
Dean’s Brother . . . . .Charlie Tocantins  
Linda . . . . .Rebecca Greig  
Party guests . . . . .Octavia Rodriguez & Stephanie Vamvoukakis

“Sun Salutation” lyrics by Josh Lewis.

### Don’t Call it a Comeback

By Liz Flahive. Directed by Megan Cramer.

Cecilia del Fuego . . . . .Megan Cruz  
Bobby Damon . . . . .Joshua Joya  
Hatchling Loggerhead . . . . .Megan Cruz

“Song of the Sea Turtle” lyrics by Liz Flahive.

### LMNOP Negative

By Willie Reale. Directed by Megan Sandberg-Zakian.

Jane Anzart . . . . .Evelyn Nicole Rosario  
Prunella . . . . .Katherine Acosta

“Annoying” lyrics by Willie Reale.

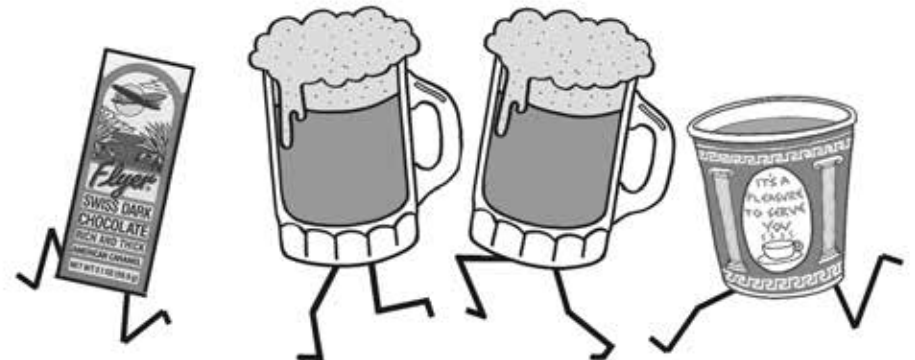

The **52nd Street Project Teen Ensemble** is a two-year program for graduates of The Project's writing and acting programs. The Teen Ensemble focuses on professional level acting technique by using both original and existing texts. The culmination of the program is the production of a play by William Shakespeare as adapted by the ensemble. The most recent teen production, **As You Like It**, was performed in the United Kingdom in the summer of 2003 at **Harrow School** in London and at the **Chateau de Berne** in Lorgues, France. The teens you see tonight will journey to Europe this summer to present a full-length version of **Measure for Measure**.

### The Project Staff

Gus Rogerson . . . . .Artistic Director  
 Carol Ochs . . . . .Executive Director  
 John Sheehy . . . . .Director of Development  
 Megan Sandberg-Zakian . . . . .Associate Artistic Director  
 George Roman Babiak . . . . .Production Manager  
 Liz Bell . . . . .Director of Education  
 Diana Rojas . . . . .Executive Assistant  
 Mayleen Cancel . . . . .Education Assistant  
 Chris Ceraso . . . . .Teen Dean  
 Solangee Acosta, Amelia Whitney . . . . .Receptionists  
 Rebecca Grieg, Rebecca Masback . . . . .Interns

### The 52nd Street Project Board of Directors

Ben Barenholtz	Carol Ochs
Lisa Benavides	Willie Reale, <i>founder</i>
Rachel Chanoff	Gus Rogerson
Cathy Dantchik	Shirley Rumierk, <i>alumni member</i>
Noël Dawkins	José Soto, Jr., <i>alumni member</i>
Wendy Ettinger, <i>chair emeritus</i>	Pamala Tyson
Louis P. Friedman	Laura Valeroso
Stephen Graham, <i>chair</i>	Wendy vanden Heuvel
Larry Jones	John A. Vassilaros
James McDaniel	Jenny Wiener
Frances McDormand	
Patricia M. Murphy, Esq.	

## The 52nd Street Project Teen Ensemble Presents

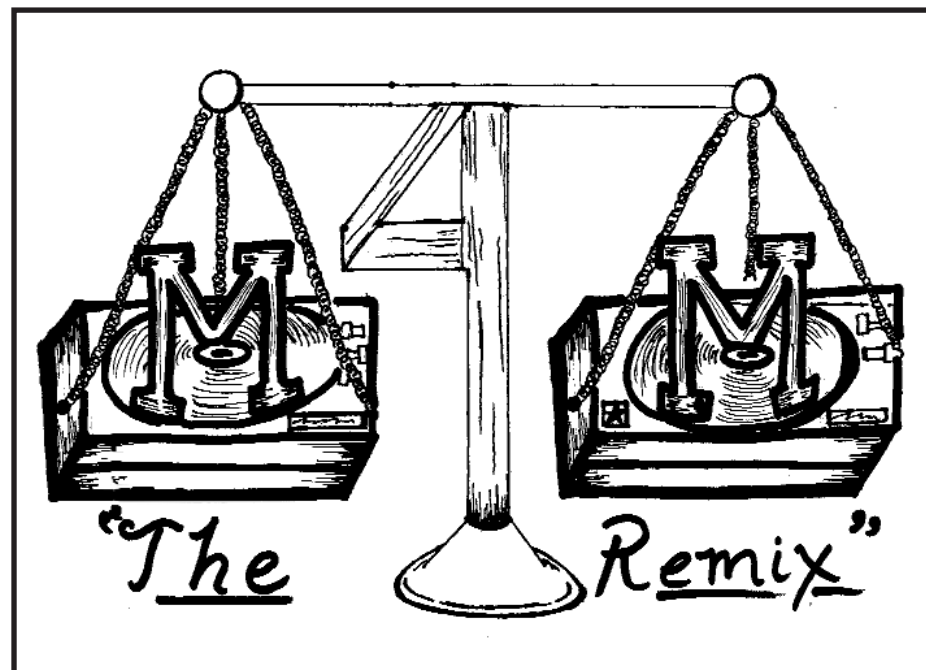

ARTWORK BY CHRISTINA RAMIREZ

# M4M: The Remix

*Scenes based on Shakespeare's*  
**"Measure for Measure"**

Thursday, March 3rd at 7:30 p.m.  
 Friday, March 4th at 7:30 p.m.

The Women's Interart Annex  
 500 W. 52nd St.

# M4M: The Remix

## **A Fearful Thing**

By Leah Galimidi

Directed by Diana Rojas

Claudio/Juan .....Christina Ramirez

Leah .....Leah Galimidi

Angelo .....Reg Flowers

Mike .....Chris Ceraso

## **Birds of Prey**

By Nadya Jabour

Directed by Megan Sandberg-Zakian

Ms. Jones .....Nadya Jabour

Ms. Geller .....Amelia Whitney

Mr. Dale .....Chris Ceraso

## **Doubts**

By Christina Ramirez

Directed by Chris Ceraso

Lucio .....Christina Ramirez

Mirror .....Leah Galimidi

Lauren .....Nadya Jabour

## **Bound To You**

By Amelia Whitney

Directed by Reg Flowers

Mariana Overdone .....Amelia Whitney

Claudio Provost .....Reg Flowers

**“The very mercy of the law cries out...  
an Angelo for Claudio, death for death...  
and measure still for measure.” –  
Measure for Measure, Act 5, Scene 1**

### **Extra Special Thanks To**

Margot Lewitin, Ronnie Geist,

Josh Liveright and

The Women’s Interart Annex;

Becky White;

Our old friends

Justin Aponte,

Joel Lind,

Robert Tomas,

and

Isaac Trujillo.

Sound:

Diana Rojas and Shevonne Hernandez

The 52nd Street Project gratefully acknowledges the support of the following foundations and corporations: American Media; Barker Welfare Foundation; Bloomberg; Blythmour Corporation; Capital Research Company; Carnegie Corporation of New York; CBS, Citigroup; Cityrest LLC; Consolidated Edison; Comedy Central; St. Vincent de Paul Foundation; The Dramatists Guild Fund; Dramatists Play Service; The Max & Victoria Dreyfus Foundation Inc.; Eleanor, Adam & Mel Dubin Foundation; Entertainment Weekly; The Horace W. Goldsmith Foundation; The Henlopen Foundation; The Hennessy Foundation; HBO; Holland Lodge Foundation, Inc.; Hurlbut Family Charitable Lead Trust; JKW Foundation; Betty E. & George B. Kaiser Foundation; Lloyds TSB Bank plc; Lucille Lortel Foundation; James A. Macdonald Foundation; MadHouse, Inc.; Ann M. Martin Foundation; Mellon Equity Associated, LLP; The New World Foundation; The New York Times Company Foundation; Newman's Own; Armstrong Nickoll Family Foundation; Noggin; Norcross Wildlife Foundation, Inc.; The Fan Fox & Leslie R. Samuels Foundation; Sesame Workshop; Stranahan Foundation; The Surdna Foundation; Theatre Communications Group, Inc.; The Vervane Foundation; John A. Vassilaros & Son, Inc; The Wiener Family Foundation; Yorke Construction Corporation; Felix Zarembo & Co. Inc. In addition the following individuals made gifts of over \$200 to The 52nd Street Project this year (list is current as of 1/26/05):

Robert Abrams & Cynthia Vance	Rose Gasner & Larry Chertoff	Sonia Manzano & Richard Reagan	Laura Sametz & Anton Fig
Cecilia Arana-Grant & Kevin Grant	Alexandra Gersten & John Vassilaros	Donald Margulies & Lynn Street	Karin & Tom Schall
Adam Leitman Bailey	Cora Cahan & Bernard Gersten	Gene & Mary Ann McCoy	Maury Schott
Ben Barenholtz	Nancy Giles	Paul McCrane & Dana Kellin	Lauren Seikaly & Michael Huber
Jessica Bauman & Ben Posel	Lloyd & Kitty Gilmour	Fran McDormand & Joel Coen	Jeffrey Seller & Joshua Lehrer
Meredith Beeuwkes	Judy Goldman & Michael Pillingier	Andrew McKeon	Mitchell Semel & Colleen Carroll
Lisa Benavides & Tim Nelson	George & Amy Goldstein	Rick Meese & Dan Lori	Aaron & Elaine Shapiro
Gavin Berger & Craig Berggren	Larry & Carol Goldstein	Danny Meisner	Pam Shaw & Victor Szymis
Alexander & Elizabeth Bernstein	James & Virginia Graham	Josie Merck & Jim Stevenson	Seth Shepsle
Jeanette & Samuel Black	Stephen & Cathy Graham	Brian Mertes	Peter Shinoda
Lewis Black	Connie Grappo & Lee Wilkof	Audrey & Danny Meyer	Mitchell Silverman
Tessa Blake	Emily Grishman & Susan Sampliner	Judy Minor	Meg Simon
Buzz Bovshow	Bruce Grossberg & Laura Rovinsky	Emily & John Morgan	Landon Slane
Jon Brielle	Lisa Gugenheim	Mala & Sham Mosher	Jeff Stafford
Kathy Briggs	Alan Halperin & Wendy Halperin	Walter Mosley	John Steber & Robert Shaffron
Becky Browder & Ted Neustadt	Jane & Jonathan Heine	Keith & Judy Muhleman	Jean Stein
Deborah Brown	Peter Herdrich & Karen Trott	Michelle Multz & Morty Gudelsky	R.L. Stine & Jane Stine
Susan Bruce & Peter Hedges	Amy Herzig	Suzen Murakoshi & Mark Temme	Susanna Styron & Darrell Larson
Kate Burton & Michael Ritchie	William Holtzman & S. Sylvia Shepard	Richard Murawczyk & Laura Murawczyk	Daniel Sweet
Linda & Arthur Carter	Katy Homans & Patterson Sims	Patricia M. Murphy, Esq. & Adam Spilka	Timothy Thomas
Constance Casey	Sy Jacobs	Frank Napolitano	Adriana & Tim Stephenson
Alfred C. Cerullo III	Donna & Thomas Jaycox	Steven Neiditz & Leslie Neiditz	Richard Sweren
Rachel Chanoff	Amanda Johns	Don & Sara Nelson	Liz Tuccillo
Lielta Hesen-Cohen & Richard Cohn	Andrea Johnson	Randy & Rona Nelson	Laura Valeroso & David Seidman
Billy Crudup	Kristen Johnston	Clea Newman	Wendy vanden Heuvel & Brad Coley
Tom Cruise	Larry & Mary Jones	Edward Norton	Ed Vassallo
John Dagenhard	Aram Kailian & Eli Pariser	Kevin O'Rourke & Edith Thurber	Susan Vitucci
Arthur Dantchik	Sheryl Kaller	Carol Ochs & Bruce MacVittie	Mary Pat Walsh
Cathy Dantchik	Cindy Kaplan	Jacki Ochs & Jan Kroeze	Sam & Lynn Waterston
Leslie Dantchik	Michelle Katz	Paul & Maria Onderdonk	Brenda Wehle & John C. Lynch
Peter & Judith Dawkins	James Kern & Deborah Kern	Sascha Paladino	Randall Weisenburger
Alex Draper & Lorraine Tobias	Steven Klinsky	Elizabeth Peters	Sally & Lenny Weiss
Richard & Rebecca Dresser	Mary Kong	Peter & Ana Rosa Phillips	Ali Marsh
Christopher & Karen Eddowes	Judy Kuhn & David Schwab	Susan Ochs Phillips	Jane Bolster & Steve Wertimer
Renee Edelman	Kate Lear & Jonathan LaPook	Katharyn Pinder	Jenny Wiener & Jon Steingart
David & Chrysti Eigenberg	Liza Lerner	Jeremy & Paulette Posner	Michael & Zena Wiener
Ned Eisenberg & Patricia Maguire	Ilana Levine & Dominic Fumusa	Peter & Helen Randolph	Donald Windham
Nora Ephron	Joshua Lewis & Sarah Kay	Paul Reale & Barbara McCrane	Frank Wood
Heidi Ettinger	Anna Li	Willie Reale & Jenny Gersten	Joanne Woodward & Paul Newman
Wendy Ettinger & Derek McLane	Katherine Lumb	Theresa Rebeck & Jess Lynn	Bill Wrubel & Jennifer Crittenden
Peter Jay Fernandez & Denise Borse	John Lyons	Lise Rehwaldt & Mark Roberts	Patricia Xenos
Martin Fetner & William Coury	Grace Lyu-Volkhausen	David & Anita Rogerson	Jeffrey & Janine Yass
Liz Fillo	Greg MacPherson & Jane Perlmutter	Daryl Roth	Mei Yueh Yen
David Frankel	Doda Manalansan	Martha Roth & Bill Irwin	James & Mary Lin Yoshimura
Richard Frankel & Kathleen Clark	Paul & Lauren Mandell	Arnold & Agnes Sametz	Bill Zarembo
Alison Fraser & Nat Magee			Elisa Zuritsky & Jordan Barowitz
Frank Frattaroli			
Louis & Patrice Friedman			
Janeane Garofalo			

GUS ROGERSON  
ARTISTIC DIRECTOR

CAROL OCHS  
EXECUTIVE DIRECTOR

MEGAN SANDBERG-ZAKIAN  
PLAYMAKING DIRECTOR

THE 52ND  
STREET  
PROJECT  
PRESENTS

WHAT'S  
THE BIG  
IDEA?

PLAYS TO THINK ABOUT  
THE SPRING 2005 PLAYMAKING SHOW



FRI., APRIL 1 AT 7:30 P.M. ● SAT., APRIL 2 AT 3:00 P.M. & 7:30 P.M. ● SUN., APRIL 3 AT 3:00 P.M.

THE MARY LEA JOHNSON PERFORMING ARTS CENTER AT  
THE CALHOUN SCHOOL

433 WEST END AVENUE (CORNER OF 81ST ST.)

# WHAT'S THE BIG IDEA?

Plays to Think About - April 1-3, 2005

The Mary Lea Johnson Performing Arts Center at the Calhoun School

## The 52nd Street Project Staff:

Gus Rogerson, Artistic Director  
Carol Ochs, Executive Director  
John Sheehy, Director of Development and Marketing  
Megan Sandberg-Zakian, Associate Artistic Director  
George "X-Acto" Babiak, Production Manager  
Liz Bell, Director of Education  
Diana Rojas, Executive Assistant  
Mayleen Cancel, Education Assistant  
Chris Ceraso, Teen Dean  
Iris A. Brown, Graphic Designer  
Solangee Acosta and Amelia Whitney, Receptionists  
Becca Masback and Rebecca Greig, Interns

## Production Staff

**Composer:** Greg Pliska  
**Musical Director:** Kim Sherman  
**Set Designer:** Kevin Joseph Roach  
**Lighting Designer:**  
Greg MacPherson  
**Costume Designer:**  
Crystal Thompson  
**Costume Building Crew:**  
Claudia Diaz, Emily Gainfield,  
Christine Szczepanski, and Scott  
Copeck  
**Sound Designer:** Maury Schott  
**Stage Manager:**  
Jean Marie Donnelly  
**Slide Designers:**  
George Babiak, Sandra Barron,  
Chris Bonanos, Todd Levin,  
Katherine Lumb, Mike Sell,  
John Steward, Alberta Testanero

**Prop Design Team:**  
George Babiak, Krysti Eigenberg,  
Rebecca Greig, Becca Masback,  
Lee Rosen.  
**Furniture Crew:**  
Rebecca Greig, Luis Maldonado,  
Christopher Ramirez  
**Prop Crew:**  
Becca Masback, John Cuevas  
**Load-in and Light Hang Crew:**  
Ray Harold, Jeff LaGreca, Moira  
MacDonald, Gayle MacDonald,  
Anne O'Sullivan, Betsy Rhodes.  
**House Managers:**  
Karin Schall, Liz Flahive,  
Liz Bell

The Playmaking Program is made possible with public funds from The New York State Council on the Arts, a state agency, and the NEA. The 52nd Street Project is a member of Art/NY and a participant in the New Generations Program, funded by Doris Duke Charitable Foundation/The Andrew W. Mellon Foundation and administered by Theatre Communications Group, the national organization for the American Theater.



## COOL STUFF ON SALE!

Flyer Bars .....\$2.00, \$1.50 & \$1.00

*Shel Silverstein's "Fivey and Twoey" logo gear:*

Project Caps .....\$15.00

Project Mugs .....\$5.00

Project Pencil 3-pack .....\$1.00

Project Notebooks .....\$5.00

Thank you for coming to **WHAT'S THE BIG IDEA?**. If you are not on our mailing list (or if your address has changed), please fill out this form and give it to us on your way out or mail it to the address below. We would also like to know if you are interested in becoming a volunteer. We need help in **all areas**, so be sure to fill out the entire form.

### PLEASE ADD ME TO YOUR MAILING LIST:

04/05

NAME: \_\_\_\_\_

ADDRESS: \_\_\_\_\_

ZIP \_\_\_\_\_

HOME PHONE: \_\_\_\_\_

DAYTIME PHONE: \_\_\_\_\_

E-MAIL ADDRESS: \_\_\_\_\_

MY OCCUPATION: \_\_\_\_\_

MY HOBBIES: \_\_\_\_\_

### YES, I WOULD LIKE TO BE OF HELP. I CAN:

- |   |   |  |
|---|---|--|
| <input type="checkbox"/> Help load in and out for shows | <input type="checkbox"/> Draw and/or paint  | <input type="checkbox"/> Help kids with homework |
| <input type="checkbox"/> Hang lights                    | <input type="checkbox"/> Help with mailings | <input type="checkbox"/> Teach kids a skill      |
| <input type="checkbox"/> Work on a backstage crew       | <input type="checkbox"/> Do office work     | <input type="checkbox"/> Be a chef at an event   |
| <input type="checkbox"/> Do graphic design              | <input type="checkbox"/> Design sound       | <input type="checkbox"/> Design and sew costumes |
| <input type="checkbox"/> Other (please specify) _____   |   |  |

### MY SCHEDULE IS:

- Very flexible. I'm often available during weekdays.  
 Somewhat flexible. I can help on the occasional morning or afternoon during the week.  
 Not very flexible at all, but I've got some free time on evenings and weekends.

If you would like to mail this (and you're always welcome to enclose a tax-deductible contribution), you can send it to: **The 52nd Street Project**, 500 West 52nd St., New York, NY 10019. Or fax it to (212) 333-5598.

## Don't Miss Our Upcoming Shows!

Hank Azaria and Oliver Platt invite you to Save the Date, and possibly the World at...

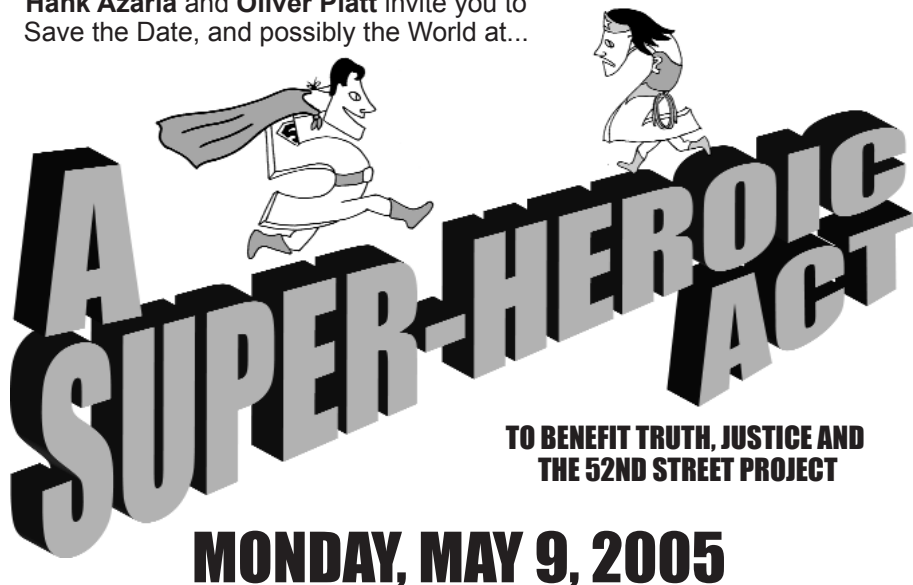

TO BENEFIT TRUTH, JUSTICE AND  
THE 52ND STREET PROJECT

**MONDAY, MAY 9, 2005**

For reservations or info call John "The Thing" Sheehy @ 212/333-5252

### William Shakespeare's **Measure for Measure**

Adapted by the teens of The 52nd Street Project  
Directed by Megan Sandberg-Zakian

#### ***Bi-Continental Tour!***

June 25 - NEW YORK CITY - The Axis Theater  
July 1 - LORGUES, FRANCE - Chateau de Berne



## **HOLIDAYS IN THE SUN**

### **THE BLOCK ISLAND PLAYS**

*THE 2005 ONE-ON-ONES*

*KIDS AND ADULTS ON STAGE TOGETHER!*

**JULY 21-24, THE ENSEMBLE STUDIO THEATER**

The 52nd Street Project is a non-profit organization that brings children from the Hell's Kitchen neighborhood together with professional theater artists to create original theater. **What's The Big Idea?** is a production of our Playmaking program. Young people participate in a nine-week playwriting course taught by Megan Sandberg-Zakian and adapted for the Project by Daniel Judah Sklar from his book *Playmaking: Children Writing and Performing Their Own Plays*. At the end of the course, each child is given two actors, a theme, and a dramaturg/director who guides him or her through the writing of a play during a weekend retreat in the country (Kent, Connecticut, for this show). Tonight's performance is the end result.

### **The 52nd Street Project Board of Directors**

Ben Barenholtz  
Lisa Benavides  
Rachel Chanoff  
Cathy Dantchik  
Noël Dawkins  
Wendy Ettinger,  
*chair emeritus*  
Louis P. Friedman  
Stephen Graham, *chair*  
Larry Jones  
James McDaniel  
Frances McDormand  
Patricia M. Murphy, Esq.

Carol Ochs  
Willie Reale,  
*founder*  
Gus Rogerson  
Shirley Rumierk,  
*alumni member*  
José Soto, Jr.,  
*alumni member*  
Pamala Tyson  
Laura Valeroso  
Wendy vanden Heuvel  
John A. Vassilaros  
Jenny Wiener

### **Special Thanks**

We're grateful to **Stephen, Cathy, Juliet, and Tommy Graham** for graciously allowing us to bring the chaos of a Playmaking weekend to their lovely home in Kent, Connecticut. Their staff gets a round of applause, too. Thanks also go to **Sam and Lynn Waterston, and Emily Armstrong and Kevin Patrick Gannon** for providing accommodations. Thanks also to **Chris Varmouse** for helping out in Playmaking class.

### **In-Kind Contributions**

The Murphy Law Office; Benefit Cosmetics; Iris A. Brown; Bourjois Paris; Bumble and bumble; Ron Kastner and Capital Printing; Kenneth Cole Productions; Noggin; The Printing Store; Scholastic, Inc.; Diageo Chateau & Estate Wines; Entertainment Weekly; Lucky Magazine; Microtouch/Finishing Touch; Molten Brown; MOP Cosmetics; Newman's Own; Pharma Print/Omni Graphics; Sesame Workshop; Wendy Stuhlberg; Terax America; John A. Vassilaros; Watkins, Inc.; Mayor's Office of Film & Television; Boylan's Bottling Co.; Steve Jenkins, David Sneddon & Fairway Market; Lorraine Tobias & Imaginary Studios; Jive Records, part of Zomba Music Group; and Prime Films.



## WHAT'S THE BIG IDEA? - ACT I

All original music composed by Greg Pliska (except where noted)

### **Nerdy Nerd and the Princess of Life**

by Stephanie Marion, age 9. Dramaturg/Director: Evan Cabnet

Princess .....Lois Smith  
Nerdy Nerd .....Joel de la Fuente  
Students .....The Crew

*"We Should be Friends"* lyrics by Stephanie Marion

### **Godzilla Meets Anaconda**

by Laron Holt, age 9. Dramaturg/Director: Reg Flowers

Anaconda .....Martin Moran  
Lize .....Marva Hicks  
Godzilla .....George Babiak

*"Burn You"* lyrics by Laron Holt

### **Broadway Miracle**

by Jenisse Bouret, age 10. Dramaturg/Director: Liza Steinberg

Ellyse .....Sarah Petersiel  
Hopefull .....Nikki Philips  
Casting Director .....John Sheehy

*"This is My Dream," "Miracle," and "What's in the Heart"* lyrics by Jenisse Bouret

### **Good Vs. Evil**

by Malik Velasquez, age 10. Dramaturg/Director: Beatrice Terry

S.A.A.J. (aka Secret Agent A.J.) .....Lee Rosen  
E.S.A.C. (aka Evil Secret Agent Christina) .....Sharon Washington  
Unconscious Cops .....Luis Maldonado & John Cuevas  
Alien Pet .....Rebecca Greig

*"Jet Pack Song"* lyrics by Malik Velasquez.

### **Fighters**

by George Keller, age 9. Dramaturg/Director: George Babiak

Tom .....Matt Saldivar  
Ishmael .....Stevie Ray Dallimore  
Brother .....John Sheehy  
Sister .....Becca Masback

*"The Stupid Mistakes"* lyrics by George Keller, music by Matt Saldivar and Stevie Ray Dallimore.

## WHAT'S THE BIG IDEA? - ACT II

### **One Sister Jealousy**

by Luisa Santiago, age 9. Dramaturg/Director: Zakiyyah Alexander

April .....Marsha Stephanie Blake  
Jenny .....Pascale Armand

*"Sisters"* lyrics by Luisa Santiago

### **Rony Makes Friends with His Own Predator**

by Analis "Fifi" Fernandez, age 9.

Dramaturg: Mayleen Cancel Director: Gus Rogerson

Rony .....Ephraim Lopez  
Dougless .....Lee Briggs  
Father .....Christopher Ramirez

*"River Song" and "Dougless Confesses"* lyrics by Analis Fernandez

### **Day After Day**

by Joyce Cheung, age 9. Dramaturg/Director: Julia Gibson

Amy .....Kathy Hiler  
Snow Ball .....Johanna Day  
Mom .....Becca Masback

*"Snow Ball's Life" and "The Happiest Day for Amy"* lyrics by Joyce Cheung

### **The Giraffe King**

by Marcus Quinones, age 9. Dramaturg/Director: Joe White

Bernie the Elephant .....Ray Harold  
Frank the Giraffe .....Arthur French

### **Brother vs. Sister**

by Amoro Pargas, age 10

Jason .....Paco Tolson  
Maria .....Kari Swenson Riely

*"I Hate My Sister" and "You Would Always Be My Brother and Sister"* lyrics by Amoro Pargas.

# I N T E R M I S S I O N



*Honorary Chairs*  
Hank Azaria and Oliver Platt  
*and Corporate Hosts*  
Ars Nova  
Louis Friedman/Bear Stearns  
Tobak-Dantchik Events  
*and the Board of Directors of*  
*The 52nd Street Project present*

# A SUPER-HEROIC ACT

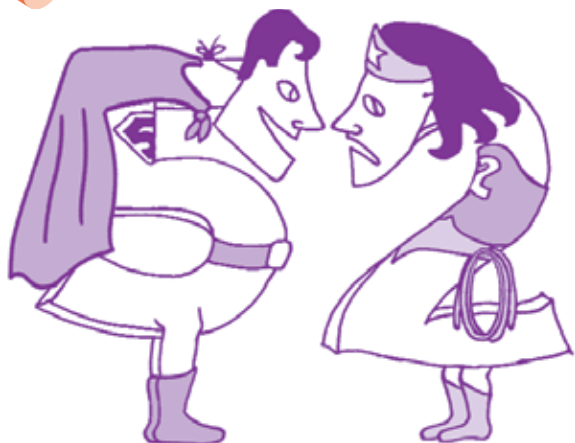

**MONDAY MAY 9, 2005**  
**AT CAPITALE**

**BOARD CHAIR**

Stephen Graham

**EXECUTIVE DIRECTOR**

Carol Ochs

**ARTISTIC DIRECTOR**

Gus Rogerson

## CO-CHAIRS

Lisa Benavides  
Becky Browder  
Cathy Dantchik  
Louis P. Friedman  
Patrice Friedman

Jenny Gersten  
Karin Schall  
Laura Valeroso  
Mary Pat Walsh  
Jenny Wiener

## THE BOARD OF DIRECTORS

Ben Barenholtz  
Lisa Benavides  
Rachel Chanoff  
Cathy Dantchik  
Wendy Ettinger,  
*chair emeritus*  
Louis P. Friedman  
Stephen Graham, *chair*  
Larry Jones  
James McDaniel  
Frances McDormand  
Noël Mihalow

Patricia M. Murphy, Esq.  
Carol Ochs  
Willie Reale, *founder*  
Gus Rogerson  
Shirley Rumierk,  
*alumni member*  
José Soto, Jr.,  
*alumni member*  
Pamala Tyson  
Laura Valeroso  
Wendy vanden Heuvel  
John A. Vassilaros

Jenny Wiener

## THE 52ND STREET PROJECT GRATEFULLY ACKNOWLEDGES...

Iris A. Brown  
Bumble and bumble  
Capital Printing/Ronald J. Kastner  
Kenneth Cole Productions  
Diageo Chateau & Estate Wines Co.  
Entertainment Weekly  
Jive Records  
*A division of Zomba Music Group*  
Lucky Magazine  
MAC  
Newman's Own  
Noggin/The N  
Pharma/Omni Printing  
Sesame Workshop  
Wendy Stulberg  
John A. Vassilaros & Sons  
Watkins Incorporated  
*Healthier Living Since 1868*

## THE PROJECT SHOW CAST

### CAST OF CHARACTERS

Aphorisma . . . . .Martha Plimpton  
Redunda . . . . .Kayelani Silva  
Captain Gesundheit . . . . .Oliver Platt  
Hanky . . . . .Zebulun Santiago  
Harpy . . . . .Sara Ramirez  
Foresight . . . . .Hera Andre-Bergmann  
The Stickler . . . . .Michael Stuhlbarg  
Nit Pick . . . . .Jason Peterson Ridge

### DIRECTED BY

Jonathan Bernstein

### WRITTEN BY

Willie Reale &  
John Sheehy

### MUSIC BY

Kim D. Sherman

### PERCUSSION

Anton Fig

### LYRICS BY

Willie Reale

### SET DESIGN AND CONSTRUCTION

George Babiak

### LIGHTING DESIGN

Greg MacPherson

### COSTUME DESIGN

Crystal Thompson

### SOUND DESIGN

Kristyn Smith

### STAGE MANAGER

Karen Munkel

## **CAPED CRUSADERS**

Arthur Dantchik  
Cathy Dantchik  
Wendy Ettinger & Derek McLane  
Patrice & Louis Friedman, Bear Sterns  
Cathy & Stephen Graham  
Jenny Wiener & Jon Steingart, Ars Nova  
Joanne Woodward & Paul Newman  
Jeff Yass

## **MASKED AVENGERS**

Brunswick Group LLC  
Frances McDormand & Joel Coen  
Clea Newman

## **LOYAL SIDEKICKS**

Amy Friedman, Noggin/The N  
Alexandra Gersten-Vassilaros &  
Johnny Coffeeshopolis  
The Saul Horowitz Jr. Fund  
Lloyds TSB Bank  
Noël & Joe Mihalow, The Dawkins  
Family Foundation  
Fred Nelson  
Lauren Seikaly & Michael Huber  
Sesame Workshop  
Showtime Networks Inc.  
Laura Valeroso & David Seidman  
Wendy vanden Heuvel  
Dr. Mildred Collier Walton  
Weil, Gotshal & Manges LLP

## **LONE CHAMPIONS**

Anonymous  
Howard Chatzinoff  
Tricia Cooke & Ethan Coen  
Leslie Dantchik  
Frank Frattaroli  
Robert C. Feldman  
Sarah Horowitz & David Venarde  
Anne Jackson & Eli Wallach  
LaTonya & Samuel L. Jackson  
Sy Jacobs  
Andrea Johnson  
Kristen Johnston  
Jane Kaczmarek  
Robert Sean Leonard

Marjorie & Michael Loeb  
Peter Manning & Andre Bishop  
Audrey & Danny Meyer  
Josephine Merck & Jim Stevenson  
Jane Musky & Tony Goldwyn  
Jane Perlmutter & Greg MacPherson  
Lise Rehwaldt & Mark Roberts  
Anita A. & David S. Rogerson  
Steve Sabba  
Simone Silverman & George Xenos  
Jane & R.L. Stine  
Laura Valeroso & David Seidman  
Yildiz Yuksek & Richard Blackstone

## **GOODIE TWO-SHOES**

Anonymous	Patricia Dunnock & Ned Eisenberg
Alexis Alexanian	Barbara Fleck-Paladino & Joseph Paladino
Dean Adrian	Katherine Freedman & Brian Bierne
Cecilia Arana-Grant & Dr. Kevin Grant	Rose Gasner & Larry Chertoff
Emily Armstrong & Thomas Patrick Gannon	Jenny Gersten & Willie Reale
Brooks Ashmanskas	Jilian Cahan Gersten
Becky Ann & Dylan Baker	Ileen Getz & Mark Grinnell
Ben Barenholtz	Nancy Giles
Lisa Benavides & Tim Blake Nelson	Connie Grappo & Lee Wilkof
Stephanie Berger & Paul King	Michael Greif & Jonathan Fried
Stephen Bernstein	Lisa J. Gugenheim & Lawrence Nathanson
Lewis Black	John Hazard
Jane Bolster & Steve Wertimer	Nina Hellman & Jeremy Shamos
Lynne & Roger Bolton	Amy Herzig
Buzz Bovshow	Marin Hinkle & Randall Sommer
Kathy Briggs & Matthew Hobbs, Dramatists Play Service	Katy Homans & Paterson Sims
Becky Browder & Ted Neustadt	Pat Ivers
Susan Bruce & Peter Hedges	Dana Ivey
Michelle Buffington	Bonnie Kantor
Denise Burse & Peter Jay Fernandez	Cynthia Kaplan & David Froelich
Colleen Carroll & Mitchell Semel	Mary Kong
Alfred C. Cerullo III	John Conlee
Rachel Chanoff	Judy Kuhn & David Schwab
Sharon Chantiles	Mickey Lemle
David Copeland	Liza Lerner
Maddie Corman & Jace Alexander	Howard Levi
Dr. Bill Coury & Martin Fetner	Aimee Levine
Paula Devicq	Ilana Levine, Dominic Fumusa & Georgia Fumusa
Rebecca & Richard Dresser	Anna Li
Moira Driscoll & David Pence	

Lorraine Lopezzo	Marcia Santoni & John Morris
D.J. Martin	Sandra Santoni
Sonya Martin & Michael Bornheimer	Karin & Thomas Schall
Nina & Robert Matza	Robin Schanzenbach
Brigid McCarthy	Maury Schott
Barbara McCrane & Paul Reale	Dana Segal
Rick Meese & Dan Lori	Stephanie Sharis
Robin Morse & Gus Rogerson	Sylvia Shepard & Will Holtzman
Suzen Murakoshi & Mark Temme	Lois Smith
Patricia Murphy & Adam Spilka	Abbot Stranahan & David Ward
Jacki Ochs & Jan Kroeze	Tracy Straus
Elise Pettus	Susanna Styron & Darrell Larson
Susan Ochs Phillips	Edith Thurber & Kevin O'Rourke
Judy & Michael Pillinger	Karen Trott & Peter Herdrich
Christopher Randolph	Liz Tuccillo
Frank Ridge	Cynthia Vance & Bob Abrams
Tatiana Rutkowsky & Andrew Blackman	Susan J. Vitucci
Agnes & Arnold Sametz	Mary Pat Walsh
Laura Sametz & Anton Fig	Carol Whitesides
	Gary Winick
	Marc D. Zand

List current as of 5/3/05

## **THE 52ND STREET PROJECT STAFF**

Gus Rogerson, Artistic Director  
Carol Ochs, Executive Director  
John Sheehy, Dir. of Development and Marketing  
George Babiak, Production Manager  
Megan Sandberg-Zakian,  
Associate Artistic Director  
Liz Bell, Director of Education  
Mayleen Cancel, Education Assistant  
Diana Rojas, Executive Assistant  
Chris Ceraso, Teen Dean  
Iris A. Brown, Graphic Designer

## **BENEFIT VOLUNTEERS**

Perry McBain Daniel, Reg Flowers, Bryan Gmitter,  
Heather Gobbee, Andrew Kelsey, Becca Masback,  
Catherine Mueller, Doug Nervik, Kari Riely,  
Lee Rosen, Victoria Row, Kim D. Sherman,  
Charlie Tocantins, Vanessa Valdes,  
Ed Vassallo, Becky White, Kurt Wootton

## **SPECIAL THANKS**

Becky Browder, William Curran, Liz Flahive,  
Terry Fitzpatrick, Amy Friedman,  
Jenny Gersten, Mark Jacobs, John Laird,  
Barbara McCrane, Christopher Randolph,  
Karin & Tom Schall, Mary Pat Walsh

GUS ROGERSON, ARTISTIC DIRECTOR

CAROL OCHS, EXECUTIVE DIRECTOR

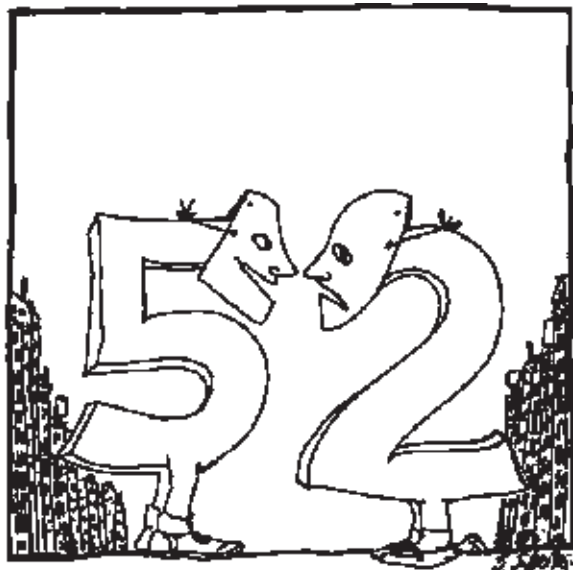

## The 52nd Street Project

*The following foundations and government agencies have generously supported the Teen Program through their contributions:*

City of New York Department of Cultural Affairs  
Max and Victoria Dreyfus Foundation  
Horace W. Goldsmith Foundation  
National Endowment for the Arts  
New York State Council on the Arts  
The Surdna Foundation



The 52nd Street Project is a participant in the **New Generations Program**, funded by **Doris Duke Charitable Foundation/The Andrew W. Mellon Foundation** and administered by **Theatre Communications Group**, the national organization for the American theatre.



THE 52ND  
STREET  
PROJECT  
PRESENTS

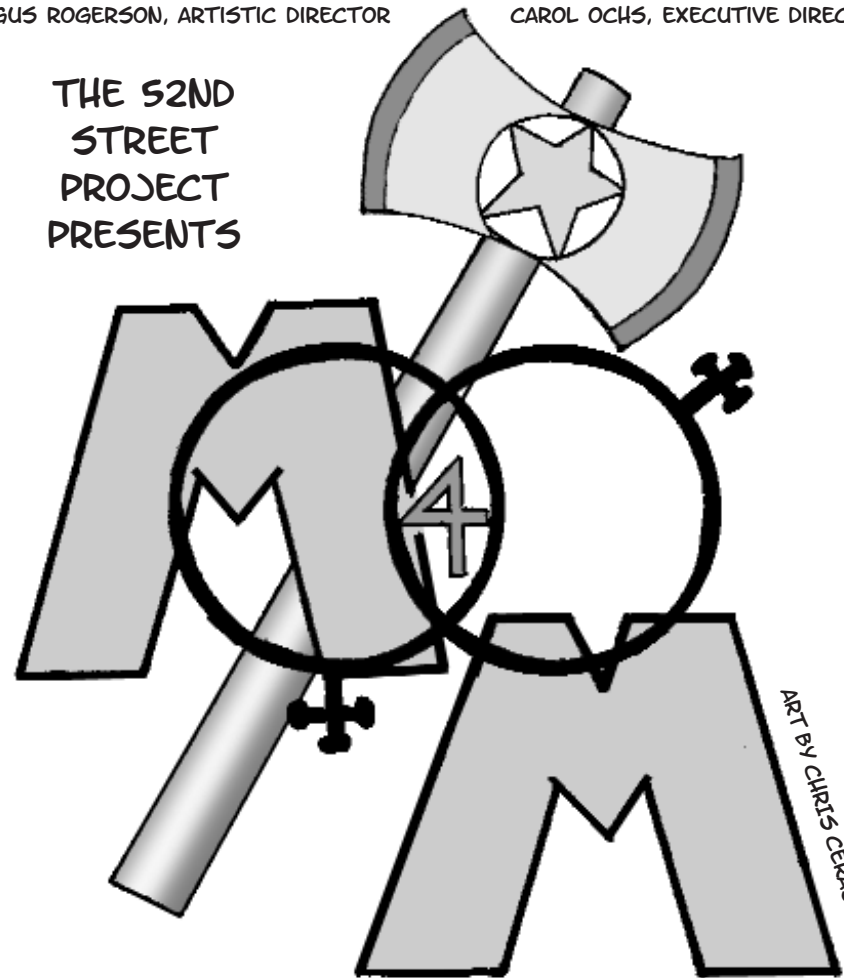

# MEASURE FOR MEASURE (MESURE POUR MESURE)

BY WILLIAM SHAKESPEARE

DIRECTED BY

MEGAN SANDBERG ZAKIAN

ADAPTED BY CHRIS CERASO

AND THE 52ND STREET PROJECT TEEN ENSEMBLE  
NEW YORK CITY: JUNE 24 & 25 - THE AXIS THEATER  
LORGUES, FRANCE: JULY 1 - CHATEAU DE BERNE

THE 2005  
NORTHERN  
HEMISPHERE  
TOUR

### The 52nd Street Project

The 52nd Street Project (The Project) is dedicated to the creation and production of new plays for, and often by, kids between the ages of ten and eighteen who reside in the Hell's Kitchen neighborhood in New York City. The Project does this through unique mentoring programs that matches kids with professional (and volunteer!) theater artists.

The Project is about making children proud of themselves. The Project is not about teaching children to act, although they will learn to. It is not about teaching them to write plays, although they will learn that as well. What it is about is giving a kid an experience of success. It is about giving a kid an opportunity to prove that he or she has something of value to offer, something that comes from within that he or she alone possesses, something that cannot be taken away.

The Project's Teen Ensemble is the final step in the kids' training: a two-year acting class that culminates in the production of a full-length play by William Shakespeare, the very one you are seeing tonight. This year's show is being done in two countries. We are very grateful to our gracious European hosts for enabling this tour.

### Le Projet de la 52ème Rue

Le Projet de la 52ème Rue est consacré à la création et production de nouvelles pièces de théâtre écrites pour, et souvent par, des jeunes de neuf à dix-huit ans qui habitent le quartier de Hell's Kitchen (Cuisine de L'enfer) à New York. Le Projet apparie ces jeunes avec des artistes de théâtre professionnels qui leur servent de mentor.

Le Projet a pour but principal l'épanouissement de l'amour-propre des enfants. Ce n'est pas une école de théâtre, bien que les enfants deviennent souvent de très bons comédiens et auteurs dramatiques. Le Projet vise plutôt à créer une ambiance dans laquelle l'enfant peut ressentir ce que c'est de réussir. En donnant aux enfants l'occasion de s'exprimer, le Projet les encourage à reconnaître qu'ils ont une voix unique, qu'elle a de la valeur, et qu'elle mérite d'être entendue.

L'Ensemble Adolescent du Projet représente la dernière étape dans la formation des jeunes: un cours de théâtre de deux ans sur l'art de jouer la comédie, menant à la production de la pièce de William Shakespeare à laquelle vous allez assister ce soir. C'est de loin la production la plus ambitieuse que nous avons montée. Elle sera jouée dans deux pays. Nous remercions nos hôtes Européens pour leur générosité, sans laquelle cette tournée n'aurait pas été possible.

## THE CAST - L'ENSEMBLE

Duke Vincentio	.....	Reg Flowers
Escalus	.....	Nadya Jabour
Angelo	.....	Rebecca White
Lucio	.....	Christina Ramirez
Dopey	.....	Rebecca White
Huey	.....	Diana Rojas
Mistress Overdone	.....	Amelia Whitney
Claudio	.....	Amelia Whitney
Provost	.....	Diana Rojas
Friar Peter	.....	Diana Rojas
Isabella	.....	Leah Galimidi
Sister Francisca	.....	Nadya Jabour
Elbow	.....	Christina Ramirez
Pompey	.....	Leah Galimidi
Froth	.....	Amelia Whitney
Juliet	.....	Christina Ramirez
Mariana	.....	Amelia Whitney
Abhorson	.....	Leah Galimidi
Barnardine	.....	Nadya Jabour

Directed by Megan Sandberg-Zakian

Costume design by Naomi Wolff

Musical direction by Rebecca White

Choreography by Megan Cramer

Program and summary translations by Alex Draper

The 52nd Street Project thanks Randy, Jeff, Brian, Jared,  
and all the other kind folks at the Axis Theatre.

We are also indebted to Bill Muddyman,  
Jane Muddyman-Heine, Jean-Yves,  
Annie, and the Staff of the Château de Berne.

The 52nd Street Project is a non-profit organization that brings children from the Hell's Kitchen neighborhood together with professional theater artists to create original theater. The Replay program gives children who are graduates of the Project's Playmaking class a chance to hone their skills in an advanced writing workshop taught by **Megan Sandberg-Zakian** and **Reg Flowers**. Over the nine weeks of Replay class, these young playwrights explored varied sources of inspiration, including a visit to the Whitney Museum and a trip to the theater, studied dramatic structure, and learned to embrace the dreaded rewrite. The resulting plays are featured in tonight's reading.

### The Project Staff

Gus Rogerson . . . . . Artistic Director  
 Carol Ochs . . . . . Executive Director  
 John Sheehy . . . . . Director of Development  
 Megan Sandberg-Zakian . . . . . Associate Artistic Director  
 George Roman Babiak . . . . . Production Manager  
 Liz Bell . . . . . Director of Education  
 Diana Rojas . . . . . Executive Assistant  
 Chris Ceraso . . . . . Teen Dean  
 Iris A. Brown . . . . . Graphic Designer  
 Solangee Acosta, Amelia Whitney . . . . . Receptionists  
 Li Cornfeld, Anikke Fox, Becca Masback . . . . . Interns

### The 52nd Street Project Board of Directors

Ben Barenholtz  
 Lisa Benavides  
 Rachel Chanoff  
 Cathy Dantchik  
 Noël Dawkins  
 Wendy Ettinger,  
*chair emeritus*  
 Louis P. Friedman  
 Stephen Graham, *chair*  
 Larry Jones  
 James McDaniel  
 Frances McDormand  
 Patricia M. Murphy, Esq.

Carol Ochs  
 Willie Reale,  
*founder*  
 Gus Rogerson  
 Shirley Rumierk,  
*alumni member*  
 José Soto, Jr.,  
*alumni member*  
 Pamala Tyson  
 Laura Valeroso  
 Wendy vanden Heuvel  
 John A. Vassilaros  
 Jenny Wiener

The 52nd Street Project Presents  
 The Third Annual

# Replay Reading

10 new plays by  
 10 young playwrights

Monday, June 6, 2005  
 7:30 p.m.

Playwrights Horizons  
 Mainstage Theater  
 416 West 42nd St.



The Playmaking Program is made possible with public funds from The New York State Council on the Arts, a state agency; and the New York City Department of Cultural Affairs. The 52nd Street Project is supported by funds from the National Endowment for the Arts, the Department of Youth and Community Development. The Project is member of ART/NY and a participant in the New Generations Program, funded by Doris Duke Charitable Foundation/The Andrew W. Mellon Foundation and administered by Theatre Communications Group, the national organization for the American Theater.



## What Can Happen When a Kid Watches T.V.

by Emmett Goodman Boyd, age 10.

Directed by John Steber

Mad Scientist .....George Babiak  
Fred's Mom .....Victoria Row  
Channel .....Nancy Giles  
Fred .....Peter Jacobson  
Fred's Friend .....Becca Masback

## My Money

by Lordan Ulloa, age 10.

Directed by Danny Goldstein

Pico .....David Costabile  
Jaylin .....Emilio Delgado  
Jake .....Chris Varmus

## Hate and Love

by Catherine Fernandez, age 11.

Directed by Lizzie Gottlieb

Ellen .....Caroline Clay  
Taurence .....Lizzy Cooper Davis

## Why Why Why

by Muhammad Cunningham, age 11.

Directed by Megan Sandberg-Zakian

Juggles .....Kevin Geer  
Josephine .....Deirdre O'Connell

## A Family Legend

By Dale Fetterman, age 12.

Directed by Reg Flowers

Jason .....Michael Alexis Palmer  
Prodigy .....Nate Corddry  
Stone .....John Sheehy  
Announcer .....Reg Flowers  
Chad .....John Sheehy

## Bob's Transformation

by Pablo Maldonado, age 11.

Directed by Lizzie Gottlieb

Bob .....Caroline Clay  
Jow .....Lizzy Cooper Davis  
Jow's Dad .....Chris Varmus  
Bob's Dad .....Chris Varmus

## The Brotherhood of the Travelling Togas

By Hera Andre-Bergmann, age 10.

Directed by John Steber

Announcer .....Victoria Row  
Dianus .....Nancy Giles  
Marcellus .....Peter Jacobson  
Herculus .....George Babiak  
Athenus .....Becca Masback  
Mom .....Victoria Row

## The Fight

By Carlos Dume, age 11.

Directed by Danny Goldstein

ZaZoul .....David Costabile  
Roger .....Emilio Delgado

## The Big Argument

By Janiece Aponte, age 11.

Directed by Megan Sandberg-Zakian

Brittney .....Deirdre O'Connell  
Daniel .....Kevin Geer

## Let's Be Friends

By Jason Gil, age 10.

Directed by Reg Flowers

Atlas .....Michael Alexis Palmer  
Fix It .....Nate Corddry  
Wrench Man .....John Sheehy

**B  
R  
I  
E  
F  
  
I  
N  
T  
E  
R  
M  
I  
S  
S  
I  
O  
N**

The 52nd Street Project gratefully acknowledges the support of the following foundations and corporations: Stephen & Mary Birch Foundation, Brunswick Group L, Capital Research Company, Carnegie Corporation of New York, CBS, Citigroup Foundation, Cityrest, LLC, Comedy Central, Consolidated Edison, The Dramatists Guild Fund, Dramatists Play Service, The Fan Fox & Leslie R. Samuels Fdn., Fox Hollow Technologies, Inc., The Horace W. Goldsmith Foundation, The Henlopen Foundation, Lloyds TSB Bank plc, Lucille Lortel Foundation, James A. Macdonald Foundation, Ann M. Martin Foundation, Mellon Equity Associated, Llp, Newnan's Own, The New York Times Company Foundation, Noggin, People Places, Inc., Sesame Workshop, Showtime Networks Inc, St. Vincent De Paul Foundation, Stranahan Foundation, The Surdna Foundation, Theatre Communications Group, Inc., John A. Vassilaros & Son, Inc., The Vervane Foundation, Weil, Gotshal & Manges Llp, Felix Zaremka & Co. Inc., Zombahn addition the following individuals made gifts of over \$250 to The 52nd Street Project this past year (list is current as of 7/01/05):

Robert Abrams & Cynthia Vance	Katherine Freedman	Doda Manalansan	Lauren Seikaly & Michael Huber
Jace Alexander & Maddie Corman	Louis & Patrice Friedman	Peter Manning & André Bishop	Mitchell Semel & Colleen Carroll
Alexis Alexanian	Rose Gasner & Larry Chertoff	Sonya Martin	Mitchell Silverman
Lawrence Alletto	John A. Vassilaros	Robert Matza & Nina Matza	Simone Silverman
Cecilia Arana-Grant & Kevin Grant	& Alexandra Gersten-Vassilaros	Fran McDormand & Joel Coen	Landon Slane
Emily Armstrong	Kilty Gilmour	Rick Meese & Dan Lori	Jean Stein
Ben Barenholtz	Tony Goldwyn & Jane Musky	Josie Merck & Jim Stevenson	Barclay Stiff
Jessica Bauman	Stephen & Cathy Graham	Audrey & Danny Meyer	Ben & Christine Stiller
Lisa Benavides & Tim Nelson	Connie Grappo & Lee Wilkof	Noël & Joe Mihalow	R.L. Stine & Jane Stine
Stephanie Berger & Paul King	Myrna & Stephen Greenberg	Suzen Murakoshi & Mark Temme	Susanna Styron & Darrell Larson
Alexander & Elizabeth Bernstein	Michael Greif & Jonathan Fried	Patricia M. Murphy, Esq.	Brian Swardstrom
Lewis Black	Emily Grishman & Susan Sampliner	& Adam Spilka	& Bonnie Bemstein
Andrew Blackman	Lisa Gugenheim & Larry Nathanson	Fred Nelson	Richard Sweren
& Tatiana Rutkowski	Nina Hellman & Jeremy Shamos	Randy & Rona Nelson	Leonard Tow
Richard Blau	Peter Herdrich & Karen Trott	James Neuberger	Liz Tuccillo
Roger Bolton & Lynne Bolton	William Holtzman	& Helen Stambler	John Turturro & Katherine Borowitz
Becky Browder & Ted Neustadt	& S. Sylvia Shepard	Clea Newman	Laura Valeroso & David Seidman
Susan Bruce & Peter Hedges	Katy Homans & Patterson Sims	Kevin O'Rourke & Edith Thurber	Wendy vanden Heuvel
Cora Cahan & Bernard Gersten	Sarah Horowitz & David Venarde	Carol Ochs & Bruce MacVittie	& Brad Coley
Rachel Chanoff	Saul Horowitz	Jacki Ochs & Jan Kroeze	Ed Vassallo
Howard Chatzinoff	Anne & Eli Jackson	Elizabeth Peters	John A. Vassilaros & Alexandra
John Ellison Conlee	LaTanya & Samuel Jackson	Bat-Sheva & Thomas Peters	Gersten- Vassilaros
Tricia Cooke & Ethan Coen	Sy Jacobs	Judy Goldman & Michael Pillinger	Claudia Wagner
Arthur Dantchik	Andrea Johnson	Peter & Helen Randolph	Mary Pat Walsh
Cathy Dantchik	Kristen Johnston	Paul Reale & Barbara McCrane	Borah & Mildred Walton
Leslie Dantchik	Larry & Mary Jones	Willie Reale & Jenny Gersten	Lynn & Sam Waterston
Sherry Davis & Mark Alhadeff	Jane Kaczmarek	Lise Rehwaldt & Mark Roberts	Sally & Lenny Weiss
Peter & Judith Dawkins	Cindy Kaplan	Julie Ridge	Jane Bolster & Steve Wertimer
Richard & Rebecca Dresser	Michelle Katz	David & Anita Rogerson	Jenny Wiener & Jon Steingart
Nora Ephron	Judy Kuhn & David Schwab	Shirley Rumierk	Michael & Zena Wiener
Heidi Ettinger	Stephen Lebovitz	Steve Sabba	Joanne Woodward & Paul Newman
Wendy Ettinger & Derek McLane	Robert Sean Leonard	Laura Sametz & Anton Fig	Jeffrey & Janine Yass
Robert Feldman	Liza Lerner	Marcia Santoni & John Morris	Mei Yueh Yen
Peter Jay Fernandez	Michael Loeb & Marjorie Loeb	Meredith Beeuwkes	
& Denise Burse	Greg MacPherson	Karin & Tom Schall	
Frank Frattaroli	& Jane Perlmutter	Maury Schott	

THE 52ND STREET PROJECT  
PRESENTS THE 2005  
HAROLD AND MIMI STEINBERG  
CHARITABLE TRUST ONE-ON-ONES



# HOLIDAYS IN THE SUN

## THE BLOCK ISLAND EDITION



JAMES STEVENSON

JULY 22-24, 2005  
THE ENSEMBLE STUDIO THEATRE  
549 WEST 52ND ST.  
NEW YORK CITY



# HOLIDAYS IN THE SUN

THE 2005 BLOCK ISLAND  
ONE-ON-ONES  
JULY 22-24  
THE ENSEMBLE  
STUDIO THEATRE



## The 52nd Street Project Staff:

Gus Rogerson, Artistic Director  
Carol Ochs, Executive Director  
John Sheehy, Director of Development and Marketing  
Reg Flowers, Associate Artistic Director  
George "X-Acto" Babiak, Production Manager  
Liz Bell, Director of Education  
Diana Rojas, Executive Assistant  
Mayleen "Star" Cancel, Education Assistant  
Chris Ceraso, Teen Dean  
Iris A. Brown, Graphic Designer  
Solangee Acosta & Amelia Whitney, Receptionist  
Interns: Li Cornfeld, Anikke Fox

## Production Staff

### Composer:

Kim D. Sherman

### Set Designer:

Kevin Joseph Roach

### Lighting Designer:

Greg MacPherson

### Costume Designer:

Lora Lavon

### Goddess of Sound:

Vanessa Valdes

### Stage Manager:

Allison Kyle

### Slide Design Team:

George Babiak, Liz Bell, Angel Desai, Reg  
Flowers, Lee Rosen, John Sheehy

### Prop Design Team:

George Babiak, Li Cornfeld, Angel Desai,  
Reg Flowers, Nedra Gallegos, Allison Kyle,  
Sascha Paladino and Erin Tomeo, Lee  
Rosen, John Sheehy

### Holidays in the Sun Illustration:

James Stevenson

### Furniture Crew:

Anikke Fox, Leah Galimidi

### Prop Crew:

Li Cornfeld, Amelia Whitney

### Load-in and Light-hang Crew:

Li Cornfeld, Angel Desai, Anikke Fox,  
Allison Kyle, Lee Rosen, Tom Schall

### House Manager:

Karin Schall

### Chefs:

Pat Ritter and Martha Velie-Gass

### Teen Counselors:

Leah Galimidi and Amelia Whitney

## COOL STUFF ON SALE IN THE LOBBY!

The Fabulous Flyer Bar . . . . . \$2, \$1.50 & \$1  
and featuring Shel Silverstein's "Fivey and Twoey" logo:

Project T-shirts (NEW Design) . . . . . \$12.00  
Project Tank Tops (NEW Girls' Design) . \$12.00  
Project Caps (NEW design) . . . . . \$15.00  
Project Mugs (now in BLUE!) . . . . . \$5.00  
Project Pencil 3-pack (now in RED!) . . . . \$1.00  
Project Notebook (New Item) . . . . . \$5.00

Thank you for coming to **HOLIDAYS IN THE SUN!** If you are not on our mailing list (or if your address has changed), please fill out this form and give it to us on your way out or mail it to the address below. We would also like to know if you are interested in becoming a volunteer. We need help in **all areas**, so be sure to fill out the entire form.

### PLEASE ADD ME TO YOUR MAILING LIST:

7/05

NAME: \_\_\_\_\_

ADDRESS: \_\_\_\_\_

ZIP \_\_\_\_\_

HOME PHONE: \_\_\_\_\_

DAYTIME PHONE: \_\_\_\_\_

E-MAIL ADDRESS: \_\_\_\_\_

MY OCCUPATION: \_\_\_\_\_

MY HOBBIES: \_\_\_\_\_

### YES, I WOULD LIKE TO BE OF HELP. I CAN:

- |   |   |  |
|---|---|--|
| <input type="checkbox"/> Help load in and out for shows | <input type="checkbox"/> Draw and/or paint  | <input type="checkbox"/> Help kids with homework |
| <input type="checkbox"/> Hang lights                    | <input type="checkbox"/> Help with mailings | <input type="checkbox"/> Teach kids a skill      |
| <input type="checkbox"/> Work on a backstage crew       | <input type="checkbox"/> Do office work     | <input type="checkbox"/> Be a chef at an event   |
| <input type="checkbox"/> Do graphic design              | <input type="checkbox"/> Design sound       | <input type="checkbox"/> Design and sew costumes |
| <input type="checkbox"/> Other (please specify) _____   |   |  |

### MY SCHEDULE IS:

- Very flexible. I'm often available during weekdays.  
 Somewhat flexible. I can help on the occasional morning or afternoon during the week.  
 Not very flexible at all, but I've got some free time on evenings and weekends.

If you would like to mail this (and you're always welcome to enclose a tax-deductible contribution), you can send it to: **The 52nd Street Project**, 500 West 52nd St., New York, NY 10019. Or fax it to (212) 333-5598.



The One-on-Ones Program is made possible with public funds from The New York State Council on the Arts, a state agency; and the New York City Department of Cultural Affairs. The 52nd Street Project is supported by funds from the National Endowment for the Arts, the Department of Youth and Community Development. The Project is member of ART/NY and a participant in the New Generations Program, funded by Doris Duke Charitable Foundation/The Andrew W. Mellon Foundation and administered by Theatre Communications Group, the national organization for the American Theater.



## Don't Miss Our Upcoming Shows!



THE WAREHAM, MASS.  
ONE-ON-ONES

10 NEW KIDS!  
10 NEW ADULTS!  
10 NEW PLAYS!  
SAME OLD  
THEME!

AUG. 18-21

RIGHT HERE AT THE  
ENSEMBLE STUDIO  
THEATRE

The 52nd Street Project is a non-profit organization that brings children from the Hell's Kitchen neighborhood together with professional theater artists to create original theater. **HOLIDAYS IN THE SUN** is a production of our One-on-One program, which is designed to give children the opportunity to go away for one-week stays in the country and enjoy the undivided attention of a professional theater artist who serves as friend, mentor, and collaborator. The Project is delighted to return to the Ensemble Studio Theatre, where we have been performing since our inception in 1981. We gratefully acknowledge the fact that if E.S.T. wasn't here, we'd be nowhere.

### The 52nd Street Project Board of Directors

Ben Barenholtz

Lisa Benavides

Rachel Chanoff

Cathy Dantchik

Noël Dawkins

Wendy Ettinger, *chair emeritus*

Louis P. Friedman

Stephen Graham, *chair*

Larry Jones

James McDaniel

Frances McDormand

Patricia M. Murphy, Esq.

Carol Ochs

Willie Reale, *founder*

Gus Rogerson

Shirley Rumierk, *alumni member*

José Soto, Jr., *alumni member*

Pamala Tyson

Laura Valeroso

Wendy vanden Heuvel

John A. Vassilaros

Jenny Wiener

## CHILL AND SERVE THE REVENGE PLAYS

The 2005 Playback Production, October, 2005

First a kid writes a short play. Then, an adult writes an "answer" play. Then, the two of them perform both plays. Multiply this equation by seven and you've got an entire show.

## OH NO YOU DIDN'T!

PLAYS THAT DO!

December, 2005

In September, 10 brand-new kids will begin a Playmaking class taught by **Reg Flowers**, our brand-new Project Playmaking Director. Come and see their final plays performed by adult professional actors.

### Special Thanks

Our Host Families – Sue Black; Nancy & John Doolittle; Josie Merck & Jim Stevenson; Theresa & Jack Sisto; Jennifer & Elliot Taubman; Ron & Judy Tierney; Joya Verde & Virginia Dare; and our headquarters host Dr. Christina Biaggi.

Sincere thanks to our chefs Pat Ritter & Martha Velie-Gass; Lynn Reale, Kate & everyone at Block Island Realty; Prudy, Jean and The Ice Cream Place; Rita & Steve Draper; Glenn & Annie Hall; McQuade's Market; Interstate Navigation; Sophia Ochs MacVittie; Jenny Ritter; Amanda Gass; Mary & John at Smuggler's Cove Sailing School; Amy Jaffe; Ed Berube; Amelia Gallant at the Block Island Grocery; Cindy & Stan Geer at the Depot; The Homans Family; Chuck the electrician; and Charlie Gale.

### In-Kind Contributions

Curt, John, Theresa, and everyone at the Ensemble Studio Theatre; the Murphy Law Office; Benefit Cosmetics; Iris A. Brown; Bourjois Paris; Bumble and bumble; Ron Kastner and Capital Printing; Kenneth Cole Productions; Noggin; The Printing Store; Scholastic, Inc.; Diageo Chateau & Estate Wines; Entertainment Weekly; Lucky Magazine; Microtouch/Finishing Touch; Molten Brown; MOP Cosmetics; Newman's Own; Pharma Print/Omni Graphics; Sesame Workshop; Wendy Stuhlberg; Terax America; John A. Vassilaros; Watkins, Inc.; Mayor's Office of Film & Television; Boylan's Bottling Co.; David Sneddon & Fairway Market; Lorraine Tobias & Imaginary Studios; Jive Records, part of Zomba Music Group; and Prime Films.

## HOLIDAYS IN THE SUN - ACT 1

All original music composed by Kim D. Sherman  
"Holidays In The Sun Theme Song" lyrics by John Sheehy

### JUST DESERT

Written & Directed by Perry Daniel for Hera Andre-Bergmann, age 11

Zora .....Hera Andre-Bergmann  
Daria .....Perry Daniel  
Vendher .....Amelia Whitney

"Sand Sonata" lyrics by Perry Daniel

### SNAKE-EYES AND MEATHEAD

Written & Directed by Lee Rosen for Jennifer Ramirez, age 11

Meathead Rabinowitz .....Lee Rosen  
Snake-Eyes Canseco .....Jennifer Ramirez  
Alfredo Fettuccine .....George Babiak  
Two prison guards .....Leah Galimidi and Amelia Whitney

"Breakout" lyrics by Lee Rosen

### HOLIDAYS AT SEA

Written by Neena Beber and Directed by Angel Desai for Malik Velazquez,  
age almost 10

Skipper .....Angel Desai  
Captain .....Malik Velazquez

"Rolling On" lyrics by Neena Beber

### THE FIERCE AND THE FABULOUS

Written by Reg Flowers and Directed by Diana Rojas for Carla Olivia, age 11

Sylvia Sleuth .....Diana Rojas  
Alexis Cunning .....Carla Olivia  
Dr. Revloni .....Reg Flowers

"Young and Pretty" lyrics by Reg Flowers

### THE HUSTLE

Written & Directed by Josh Lewis for Bryant Acosta, age almost 12

Rico .....Bryant Acosta  
Sonny .....Josh Lewis  
A Cop .....Leah Galimidi

"The Hustle 2005" lyrics & music by Josh Lewis

## HOLIDAYS IN THE SUN - ACT 2

### THE UNKINDEST CUT

Written and Directed by John Sheehy for Stephanie Vamvoukakis, age 11

Jerrold .....John Sheehy  
Stacy .....Stephanie Vamvoukakis

"The Hardest Thing" lyrics by John Sheehy

### SUAVE, SMOOTH, SUPERSPY

Written & Directed by Sascha Paladino for Jason Gill, age 10

Jimmy Blank .....Sascha Paladino  
Johnny Smiles .....Jason Gil  
Chief .....Li Cornfeld

"If You Wanna Be a Spy" lyrics by Sascha Paladino

### A SNOWFLAKE'S CHANCE IN H-E DOUBLE HOCKEY STICKS

Written by Erin Quinn Purcell & Directed by Melissa Jones  
for Samantha Toro, age 11

Flake .....Melissa Jones  
Snow .....Samantha Toro  
Starfish .....Leah Galimidi  
Santa .....George Babiak

"Christmas Tonight!" lyrics by Erin Quinn Purcell

### CLEOPATRA JAMES AND THE CURSE OF M'HEK'NA'HAY

Written by Adam Felber and Directed by Sarah Petersiel  
for Stephanie Marion, age 10

Dr. Cleopatra James .....Stephanie Marion  
Dr. Shirley Malmstein .....Sarah Petersiel  
Dr. Minky .....Reg Flowers  
Juan .....Andrew Kelsey  
The Excavettes .....Angel Desai, Josh Lewis, Lee Rosen

"We Dig It" lyrics by Adam Felber

### YOU COULD HAVE BEEN BETTER

Written by Willie Reale and Directed by Andrew Kelsey  
for Lordan Ulloa, age 10

Mike .....Lordan Ulloa  
Alec .....Andrew Kelsey  
Woman with document .....Li Cornfeld

"You Should Have Called Candy" lyrics by Willie Reale

 **Intermission!** 

The 52nd Street Project gratefully acknowledges the support of the following foundations and corporations: Stephen & Mary Birch Foundation; Brunswick Group LLP; Capital Research Company; Carnegie Corporation of New York; CBS; Citigroup Foundation; Cityrest, LLC; Clinton Seed Fund; Comedy Central; Consolidated Edison; The Dramatists Guild Fund; Dramatists Play Service; The Fan Fox & Leslie R. Samuels Foundation.; Fox Hollow Technologies, Inc.; The Horace W. Goldsmith Foundation; The Henlopen Foundation; Holland Lodge Foundation; Lloyds TSB Bank plc; Lucille Lortel Foundation; James A. Macdonald Foundation; Ann M. Martin Foundation; Mellon Equity Associated, LLP; Newman's Own; The New York Times Company Foundation; Noggin; People Places, Inc.; Sesame Workshop; Showtime Networks Inc; St. Vincent De Paul Foundation; Stranahan Foundation; The Surdna Foundation; Theatre Communications Group, Inc.; Tiger Baron Foundation; John A. Vassilaros & Son, Inc.; The Vervane Foundation; Weil, Gotshal & Manges LLP; Felix Zarembo & Co. Inc.; Zombaln addition the following individuals made gifts of over \$250 to The 52nd Street Project this past year (list is current as of 7/01/05):

Robert Abrams & Cynthia Vance	Louis & Patrice Friedman	Peter Manning & André Bishop	Mitchell Semel & Colleen Carroll
Jace Alexander & Maddie Corman	Rose Gasner & Larry Chertoff	Sonya Martin	Mitchell Silverman
Alexis Alexanian	John A. Vassilaros &	Robert Matza & Nina Matza	Simone Silverman
Lawrence Alieto	Alexandra Gersten-Vassilaros	Fran McDormand & Joel Coen	Landon Slane
Cecilia Arana-Grant & Kevin Grant	Scott & Laura Gewirtz	Rick Meese & Dan Lori	Jean Stein
Emily Armstrong	Kilty Gilmour	Josie Merck & Jim Stevenson	Barclay Stiff
Ben Barenholtz	Tony Goldwyn & Jane Musky	Audrey & Danny Meyer	Ben & Christine Stiller
Jessica Bauman	Stephen & Cathy Graham	Noël & Joe Mihalow	R.L. Stine & Jane Stine
Lisa Benavides & Tim Nelson	Connie Grappo & Lee Wilkof	Suzen Murakoshi & Mark Temme	Susanna Styron & Darrell Larson
Stephanie Berger & Paul King	Myrna & Stephen Greenberg	Patricia M. Murphy, Esq. & Adam Spilka	Brian Swardstrom & Bonnie Bernstein
Alexander & Elizabeth Bernstein	Michael Greif & Jonathan Fried	Don & Sara Nelson	Richard Sweren
Lewis Black	Emily Grishman & Susan Sampliner	Fred Nelson	Leonard Tow
Andrew Blackman	Lisa Gugenheim & Larry Nathanson	Randy & Rona Nelson	Liz Tuccillo
& Tatiana Rutkowski	Nina Hellman & Jeremy Shamos	James Neuberger & Helen Stambler	John Turturro & Katherine Borowitz
Richard Blau	Peter Herdrich & Karen Trott	Clea Newman	Laura Valeroso & David Seidman
Roger Bolton & Lynne Bolton	William Holtzman	Kevin O'Rourke & Edith Thurber	Wendy vanden Heuvel & Brad Coley
Becky Browder & Ted Neustadt	& S. Sylvia Shepard	Carol Ochs & Bruce MacVittie	Ed Vassallo
Susan Bruce & Peter Hedges	Katy Homans & Patterson Sims	Jacki Ochs & Jan Kroeze	John A. Vassilaros & Alexandra Gersten- Vassilaros
Cora Cahan & Bernard Gersten	Sarah Horowitz & David Venarde	Elizabeth Peters	Claudia Wagner
Rachel Chanoff	Saul Horowitz	Bat-Sheva & Thomas Peters	Mary Pat Walsh
Howard Chatzinoff	Anne & Eli Jackson	Judy Goldman & Michael Pillingner	Borah & Mildred Walton
Ronald Cohen	LaTanya & Samuel Jackson	Peter & Helen Randolph	Lynn & Sam Waterston
John Ellison Conlee	Sy Jacobs	Paul Reale & Barbara McCrane	Sally & Lenny Weiss
Tricia Cooke & Ethan Coen	Andrea Johnson	Willie Reale & Jenny Gersten	Jane Bolster & Steve Wertimer
Arthur Dantchik	Kristen Johnston	Lise Rehwaldt & Mark Roberts	Jenny Wiener & Jon Steingart
Cathy Dantchik	Larry & Mary Jones	Julie Ridge	Michael & Zena Wiener
Leslie Dantchik	Jane Kaczmarek	David & Anita Rogerson	Joanne Woodward & Paul Newman
Shery Davis & Mark Alhadeff	Cindy Kaplan	Shirley Rumierk	Jeffrey & Janine Yass
Peter & Judith Dawkins	Michelle Katz	Steve Sabba	Mei Yueh Yen
Richard & Rebecca Dresser	Judy Kuhn & David Schwab	Laura Sametz & Anton Fig	
Nora Ephron	Stephen Lebovitz	Marcia Santoni & John Morris	
Heidi Ettinger	Robert Sean Leonard	Meredith Beeuwkes	
Wendy Ettinger & Derek McLane	Liza Lerner	Karin & Tom Schall	
Robert Feldman	Michael Loeb & Marjorie Loeb	Robert Schnur	
Peter Jay Fernandez	Grace Lyu-Volkhausen	Maury Schott	
& Denise Burse	Greg MacPherson	Lauren Seikaly & Michael Huber	
Frank Frattaroli	& Jane Perlmutter		
Katherine Freedman	Doda Manalansan		

THE 52ND STREET PROJECT  
PRESENTS THE 2005  
WIENER FAMILY FOUNDATION  
ONE ON ONES



# HOLIDAYS IN THE SUN

THE WAREHAM, MASS. EDITION



JAMES STEVENSON

AUGUST 18-21, 2005  
THE ENSEMBLE STUDIO THEATRE  
549 WEST 52ND ST.  
NEW YORK CITY

# HOLIDAYS IN THE SUN

THE 2005  
WIENER FAMILY FOUNDATION  
WAREHAM, MASS. ONE-ON-ONES  
AUGUST 18-21  
THE ENSEMBLE STUDIO THEATRE

## The 52nd Street Project Staff:

Gus Rogerson, Artistic Director  
Carol Ochs, Executive Director  
John Sheehy, Director of Development and Marketing  
Reg Flowers, Associate Artistic "Cruise" Director  
George "X-Acto" Babiak, Production Manager  
Liz Bell, Director of Education  
Diana Rojas, Executive Assistant  
Mayleen "Star" Cancel, Education Assistant  
Chris Ceraso, Teen Dean  
Iris A. Brown, Graphic Designer  
Solangee Acosta & Amelia Whitney, Receptionist  
Interns: Li Cornfeld, Anikke Fox



## Production Staff

### Composer:

Patrick Barnes

### Set Designer:

Kevin Joseph Roach

### Lighting Designer:

Greg MacPherson

### Costume Designer:

Abby Taylor Redmond

### Sound Designer: Andrew Kelsey

### Sound Operator: Mayleen Cancel

### Stage Manager:

Karen Munkel

### Background Slide Designer:

Mike Sell

### Prop Design Team:

George Babiak, Liz Bell, Heather  
Camduff, Angel Desai, Anikke Fox, Karen  
Munkel, Matthew Ortiz, Lee Rosen, John  
Sheehy

### Holidays in the Sun Illustration:

James Stevenson

### Furniture Crew:

Li Cornfeld, Paul Dixon, Mark  
Gamero, Joshua Joya

### Prop Crew:

Nicole Fargardo, Anikke Fox

### Load-in and Light-hang Crew:

Li Cornfeld, Anikke Fox, the wonderful  
Doug Nervik, the great Charlie  
Tocantins

### House Manager:

Liz Bell, Karin Schall

### Chefs:

Liz Bell, Carol Ochs, Christopher  
Randolph, John Sheehy

### Teen Counselors:

Mark Gamero and Joshua Joya

## COOL STUFF ON SALE IN THE LOBBY!

The Fabulous Flyer Bar .....\$2, \$1.50 & \$1  
and featuring Shel Silverstein's "Fivey and Twoey" logo:  
Project T-shirts (NEW Design) .....\$12.00  
Project Tank Tops (NEW Girls' Design) . \$12.00  
Project Caps (NEW design) .....\$15.00  
Project Mugs (now in BLUE!) .....\$5.00  
Project Notebook (New Item) .....\$5.00

Thank you for coming to **HOLIDAYS IN THE SUN!** If you are not on our mailing list (or if your address has changed), please fill out this form and give it to us on your way out or mail it to the address below. We would also like to know if you are interested in becoming a volunteer. We need help in **all areas**, so be sure to fill out the entire form.

### PLEASE ADD ME TO YOUR MAILING LIST:

8/05

NAME: \_\_\_\_\_

ADDRESS: \_\_\_\_\_

ZIP \_\_\_\_\_

HOME PHONE: \_\_\_\_\_

DAYTIME PHONE: \_\_\_\_\_

E-MAIL ADDRESS: \_\_\_\_\_

MY OCCUPATION: \_\_\_\_\_

MY HOBBIES: \_\_\_\_\_

### YES, I WOULD LIKE TO BE OF HELP. I CAN:

- |   |   |  |
|---|---|--|
| <input type="checkbox"/> Help load in and out for shows | <input type="checkbox"/> Draw and/or paint  | <input type="checkbox"/> Help kids with homework |
| <input type="checkbox"/> Hang lights                    | <input type="checkbox"/> Help with mailings | <input type="checkbox"/> Teach kids a skill      |
| <input type="checkbox"/> Work on a backstage crew       | <input type="checkbox"/> Do office work     | <input type="checkbox"/> Be a chef at an event   |
| <input type="checkbox"/> Do graphic design              | <input type="checkbox"/> Design sound       | <input type="checkbox"/> Design and sew costumes |
| <input type="checkbox"/> Other (please specify) _____   |   |  |

### MY SCHEDULE IS:

- Very flexible. I'm often available during weekdays.  
 Somewhat flexible. I can help on the occasional morning or afternoon during the week.  
 Not very flexible at all, but I've got some free time on evenings and weekends.

If you would like to mail this (and you're always welcome to enclose a tax-deductible contribution), you can send it to: **The 52nd Street Project**, 500 West 52nd St., New York, NY 10019. Or fax it to (212) 333-5598.



The One-on-Ones Program is made possible with public funds from The New York State Council on the Arts, a state agency; and the New York City Department of Cultural Affairs. The 52nd Street Project is supported by funds from the National Endowment for the Arts, the Department of Youth and Community Development. The Project is member of ART/NY and a participant in the New Generations Program, funded by Doris Duke Charitable Foundation/The Andrew W. Mellon Foundation and administered by Theatre Communications Group, the national organization for the American Theater.



NATIONAL  
ENDOWMENT  
FOR THE ARTS

State of the Arts



**Don't Miss Our Upcoming Shows!**

# CHILL AND SERVE

## THE REVENGE PLAYS

**The 2005 Playback Production, October, 2005**

First a kid writes a short play. Then, an adult writes an "answer" play. Then, the two of them perform both plays. Multiply this equation by seven and you've got an entire show.

# OH NO YOU DIDN'T!

## PLAYS THAT DO!

**December, 2005**

In September, 10 brand-new kids will begin a Playmaking class taught by **Reg Flowers**, our brand-new Project Playmaking Director. Come and see their final plays performed by adult professional actors.

The 52nd Street Project is a non-profit organization that brings children from the Hell's Kitchen neighborhood together with professional theater artists to create original theater. **HOLIDAYS IN THE SUN** is a production of our One-on-One program, which is designed to give children the opportunity to go away for one-week stays in the country and enjoy the undivided attention of a professional theater artist who serves as friend, mentor, and collaborator. The Project is delighted to return to the Ensemble Studio Theatre, where we have been performing since our inception in 1981. We gratefully acknowledge the fact that if E.S.T. wasn't here, we'd be nowhere.

### The 52nd Street Project Board of Directors

Ben Barenholtz	Patricia M. Murphy, Esq.
Lisa Benavides	Carol Ochs
Rachel Chanoff	Willie Reale, <i>founder</i>
Cathy Dantchik	Gus Rogerson
Wendy Ettinger, <i>chair emeritus</i>	Shirley Rumierk, <i>alumni member</i>
Louis P. Friedman	José Soto, Jr., <i>alumni member</i>
Stephen Graham, <i>chair</i>	Pamala Tyson
Larry Jones	Laura Valeroso
James McDaniel	Wendy vanden Heuvel
Frances McDormand	John A. Vassilaros
Noël Mihalow	Jenny Wiener

### Special Thanks

Our Host Families – Anne & Colin McNay; Emily & John Morgan; Suzanne & John Potts; Patty & David Straus; Bob & Marina Whitman; Joe McNay & the entire McNay family; Peter, Helen & Christopher Randolph  
Sincere Thanks to Eric Griggs; Chris Hammett; Bruce MacVittie; Robin Morse, Lucy & Francis Rogerson; Vanessa Valdes; The Wareham Gatemen; The McNay Family pools; Alice Curtin; The Watson Family; The Wareham Land Trust.

### In-Kind Contributions

Curt, John, Theresa, and everyone at the Ensemble Studio Theatre; the Murphy Law Office; Benefit Cosmetics; Iris A. Brown; Bourjois Paris; Bumble and bumble; Ron Kastner and Capital Printing; Kenneth Cole Productions; Noggin; The Printing Store; Scholastic, Inc.; Diageo Chateau & Estate Wines; Entertainment Weekly; Lucky Magazine; Microtouch/Finishing Touch; Molten Brown; MOP Cosmetics; Newman's Own; Pharma Print/Omni Graphics; Sesame Workshop; Wendy Stuhlberg; Terax America; John A. Vassilaros; Watkins, Inc.; Mayor's Office of Film & Television; Boylan's Bottling Co.; David Sneddon & Fairway Market; Lorraine Tobias & Imaginary Studios; Jive Records, part of Zomba Music Group; and Prime Films.

## HOLIDAYS IN THE SUN II - ACT 1

All original music composed by Patrick Barnes  
“Holidays In The Sun Theme Song” lyrics by John Sheehy

### OUTFIELDERS

Written by Jay Reiss & Directed by Paco Tolson  
for Junior Chatman, age 12

Ted .....Junior Chatman  
Fred .....Paco Tolson  
Announcer .....John Sheehy

“It’s The Equinox” lyrics by Jay Reiss

### IT’S ALIVE

Written & Directed by Drew Cortese for Mathew Ortiz, age 12

The Doctor .....Mathew Ortiz  
The Creature .....Drew Cortese  
First Scientist .....Mark Gamero  
Second Scientist .....Joshua Joya

“Doctor & Creature Song” lyrics by Drew Cortese

### DEAD-A-PORTER

Written by Martha Plimpton & Directed by Nikki Phillips  
for Luisa Santiago, age 9

Dr. Jennifer Lopez .....Luisa Santiago  
Det. Sanchez, Veronique, Lunatic Fan & Det. Hannigan .....Nikki Phillips

“The New Jennifer Lopez (No Relation) Song” lyrics by Martha Plimpton

### VIVA LA REVOLUTION

Written & Directed by Kate Marks for Pablo Maldonado, age 11

Lion .....Pablo Maldonado  
Tulip .....Anikke Fox  
Radio .....Patrick Barnes  
Violet .....Susan McGinnis

“Viva La Revolution: A Marching Song” lyrics by Kate Marks

### TIME OUT

Written by Michael Bernard & Directed by Elizabeth Canavan  
for Fifi Fernandez, age 9

Plimpsie .....Fifi Fernandez  
Soul .....Elizabeth Canavan

“The Bestest Time” lyrics by Michael Bernard

👉 **Intermission!** 👈

## HOLIDAYS IN THE SUN II - ACT 2

### THE SHOWDOWN

Written & Directed by George Babiak for George Keller, age 10

Tank Brannigan .....George Keller  
Crank Flannigan .....George Babiak  
Maggie .....Anikke Fox

“The Soft Drinking Song” lyrics by George Babiak

### TOO COOL PILOTS

Written & Directed by Catherine Mueller for Harlo Ulloa, age 12

Frank Sarciapone .....Harlo Ulloa  
Frances Sterngarden .....Catherine Mueller

“Two Pilots are Better Than One” lyrics by Catherine Mueller

### THE PRINCESS PLAYS BALL

Written by Jacquelyn Reingold & Directed by Susan McGinnis  
for Catherine Fernandez, age 11

Princess of the Queendom .....Catherine Fernandez  
Baseball Coach .....Susan McGinnis  
Queen of the Queendom .....Diana Rojas  
Announcer .....John Sheehy

“I’ll Have to Give Up Who I Am” lyrics by Jacquelyn Reingold

### TOMMY THE TRAINER & HIS “KID” CRUZ

Written & Directed by Joaquin Torres for Muhammad Cunningham, age 11

Tommy the Trainer .....Muhammad Cunningham  
Carlos “The Kid” Cruz .....Joaquin Torres  
Winston “The Weatherman” Jones .....Joshua Joya  
Charlie .....Mark Gamero

“Be A Champion Tonight” lyrics by Joaquin Torres

### PERMANENT VACATION

Written & Directed by Carlo Alban for Joyce Cheung, age 9

Lucy .....Joyce Cheung  
Lucky .....Carlo Alban

“A Lighthouse in the Sea” lyrics by Carlo Alban



The 52nd Street Project gratefully acknowledges the support of the following foundations and corporations: Stephen & Mary Birch Foundation; Brunswick Group LLP; Capital Research Company; Carnegie Corporation of New York; CBS; Citigroup Foundation; Cityrest, LLC; Clinton Seed Fund; Comedy Central; Consolidated Edison; The Dramatists Guild Fund; Dramatists Play Service; The Fan Fox & Leslie R. Samuels Foundation.; Fox Hollow Technologies, Inc.; The Horace W. Goldsmith Foundation; The Henlopen Foundation; Holland Lodge Foundation; Lloyds TSB Bank plc; Lucille Lortel Foundation; James A. Macdonald Foundation; Ann M. Martin Foundation; Mellon Equity Associated, LLP; Newman's Own; The New York Times Company Foundation; Noggini; People Places, Inc.; Sesame Workshop; Showtime Networks Inc; St. Vincent De Paul Foundation; Stranahan Foundation; The Surdna Foundation; Theatre Communications Group, Inc.; Tiger Baron Foundation; John A. Vassilaros & Son, Inc.; The Vervane Foundation; Weil, Gotshal & Manges LLP; Felix Zarembo & Co. Inc.; Zombaln addition the following individuals made gifts of over \$250 to The 52nd Street Project this past year (list is current as of 7/01/05):

Robert Abrams & Cynthia Vance	Louis & Patrice Friedman	Peter Manning & André Bishop	Mitchell Semel & Colleen Carroll
Jace Alexander & Maddie Coman	Rose Gasner & Larry Chertoff	Sonya Martin	Mitchell Silverman
Alexis Alexanian	John A. Vassilaros &	Robert Matza & Nina Matza	Simone Silverman
Lawrence Alieto	Alexandra Gersten-Vassilaros	Fran McDormand & Joel Coen	Landon Slane
Cecilia Arana-Grant & Kevin Grant	Scott & Laura Gewirtz	Rick Meese & Dan Lori	Jean Stein
Emily Armstrong	Kilty Gilmour	Josie Merck & Jim Stevenson	Barclay Stiff
Ben Barenholtz	Tony Goldwyn & Jane Musky	Audrey & Danny Meyer	Ben & Christine Stiller
Jessica Bauman	Stephen & Cathy Graham	Noël & Joe Mihalow	R.L. Stine & Jane Stine
Lisa Benavides & Tim Nelson	Connie Grappo & Lee Wilkof	Suzen Murakoshi & Mark Temme	Susanna Styron & Darrell Larson
Stephanie Berger & Paul King	Myrna & Stephen Greenberg	Patricia M. Murphy, Esq. & Adam Spilka	Brian Swardstrom & Bonnie Bernstein
Alexander & Elizabeth Bernstein	Michael Greif & Jonathan Fried	Don & Sara Nelson	Richard Sweren
Lewis Black	Emily Grishman & Susan Sampliner	Fred Nelson	Leonard Tow
Andrew Blackman & Tatiana Rutkowski	Lisa Gugenheim & Larry Nathanson	Randy & Rona Nelson	Liz Tuccillo
Richard Blau	Nina Hellman & Jeremy Shamos	James Neuberger & Helen Stambler	John Turturro & Katherine Borowitz
Roger Bolton & Lynne Bolton	Peter Herdrich & Karen Trott	& Helen Stambler	Laura Valeroso & David Seidman
Becky Browder & Ted Neustadt	William Holtzman	Clea Newman	Wendy vanden Heuvel & Brad Coley
Susan Bruce & Peter Hedges	& S. Sylvia Shepard	Kevin O'Rourke & Edith Thurber	Ed Vassallo
Cora Cahan & Bernard Gersten	Katy Homans & Patterson Sims	Carol Ochs & Bruce MacVittie	John A. Vassilaros & Alexandra Gersten- Vassilaros
Rachel Chanoff	Sarah Horowitz & David Venarde	Jacki Ochs & Jan Kroeze	Claudia Wagner
Howard Chatzinoff	Saul Horowitz	Elizabeth Peters	Mary Pat Walsh
Ronald Cohen	Anne & Eli Jackson	Bat-Sheva & Thomas Peters	Borah & Mildred Walton
John Ellison Conlee	LaTanya & Samuel Jackson	Judy Goldman & Michael Pillingier	Lynn & Sam Waterston
Tricia Cooke & Ethan Coen	Sy Jacobs	Peter & Helen Randolph	Sally & Lenny Weiss
Arthur Dantchik	Andrea Johnson	Paul Reale & Barbara McCrane	Jane Bolster & Steve Wertimer
Cathy Dantchik	Kristen Johnston	Willie Reale & Jenny Gersten	Jenny Wiener & Jon Steingart
Leslie Dantchik	Larry & Mary Jones	Lise Rehwaldt & Mark Roberts	Michael & Zena Wiener
Shery Davis & Mark Alhadeff	Jane Kaczmarek	Julie Ridge	Joanne Woodward & Paul Newman
Peter & Judith Dawkins	Cindy Kaplan	David & Anita Rogerson	Jeffrey & Janine Yass
Richard & Rebecca Dresser	Michelle Katz	Shirley Rumierk	Mei Yueh Yen
Nora Ephron	Judy Kuhn & David Schwab	Steve Sabba	
Heidi Ettinger	Stephen Lebovitz	Laura Sametz & Anton Fig	
Wendy Ettinger & Derek McLane	Robert Sean Leonard	Marcia Santoni & John Morris	
Robert Feldman	Liza Lerner	Meredith Beeuwkes	
Peter Jay Fernandez	Michael Loeb & Marjorie Loeb	Karin & Tom Schall	
& Denise Burse	Grace Lyu-Volkhausen	Robert Schnur	
Frank Frattaroli	Greg MacPherson	Maury Schott	
Katherine Freedman	& Jane Perlmutter	Lauren Seikaly & Michael Huber	
	Doda Manalansan		

## THE 52ND STREET PROJECT PRESENTS THE FALL 2005 PLAYBACK SHOW

# Chill AND Serve

## THE REVENGE PLAYS

### AT THE WINGS THEATRE

154 CHRISTOPHER ST.

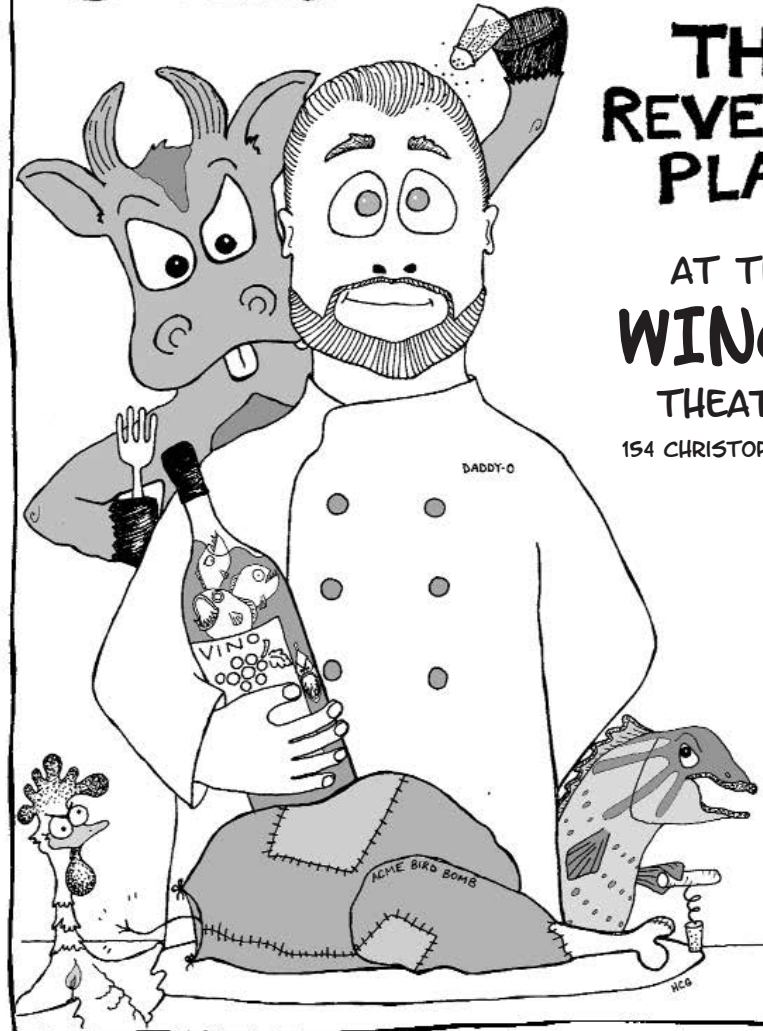

HEATHER CARNIDUFF-GOBBIE

FRI., OCT. 21 AT 7:30 P.M.  
SAT., OCT. 22 AT 3:00 P.M. AND 7:30 P.M.  
SUN., OCT. 23 AT 3:00 P.M.



# CHILL AND SERVE THE REVENGE PLAYS

THE FALL 2005 PLAYBACK SHOW OCT. 21-23 AT THE WINGS THEATRE

## The 52nd Street Project Staff:

Gus Rogerson, Artistic Director  
 Carol Ochs, Executive Director  
 John Sheehy, Director of Development and Marketing  
 George "X-Acto" Babiak, Production Manager  
 Reg Flowers, Associate Artistic Director  
 Liz Bell, Director of Education  
 Diana Rojas, Executive Assistant  
 Mayleen Cancel, Education Assistant  
 Megan Cramer, Education Liaison  
 Chris Ceraso, Teen Dean  
 Solangee Acosta, Joshua Joya, Johanna Vidal, Receptionists  
 Intern: Megan Corcoran



HEATHER CARNDUFF-GOBBER

## Production Staff:

**Composer:** Loren Toolajian  
**Set Designer:** Kevin Joseph Roach  
**Lighting Designer:** Greg MacPherson  
**Lighting Assistant:** Alex Gordon  
**Costume Designer:** Bryan Gmitter  
**Sound Designer:** Maury Schott  
**Stage Manager:** Jenni Swan  
**"Chill" Illustration:**

Heather Carnduff-Gobbee  
**Prop Design Team:**  
 George Babiak, Megan Corcoran,  
 John Sheehy, Rachel Stephens,  
 Jenni Swan

**Backstage Boss:**  
 Mean Mayleen Cancel

## Furniture Crew:

Anthony Mejia and  
 Kimani Lewis-Ashley

## Prop Crew:

Kayelani Silva and Megan Corcoran

## Load-in and Light Hang Crew:

Megan Corcoran,  
 Moira MacDonald,  
 Doug Nervik, Kevin Ryder,  
 Tom Schall, Maury Schott,  
 Jenni Swan

## House Managers:

Liz Bell and Mary Pat Walsh

## Chef:

The Incredibell Liz Bell

The Playback Program is made possible with public funds from The New York State Council on the Arts, a state agency; and the New York City Department of Cultural Affairs. The 52nd Street Project is supported by funds from the National Endowment for the Arts and the Department of Youth and Community Development. The Project is member of ART/NY and a participant in the New Generations Program, funded by Doris Duke Charitable Foundation/The Andrew W. Mellon Foundation and administered by Theatre Communications Group, the national organization for the American Theater.



## COOL STUFF ON SALE!

Flyer Bars .....\$2.00, \$1.50 & \$1.00

*Shel Silverstein's "Fivey and Twoey" logo gear:*

Project Sweatshirts .....\$20.00  
 Project Long Sleeve T-Shirts .....\$15.00  
 Project Short Sleeve T-Shirts (New colors!) ..\$12.00  
 Project Caps .....\$15.00  
 Project Mugs .....\$5.00  
 Project Spiral Notebooks .....\$5.00  
 Project Pencil 3-pack (New color!) .....\$1.00

Thank you for coming to **CHILL AND SERVE**. If you are not on our mailing list (or if your address has changed), please fill out this form and give it to us on your way out or mail it to the address below. We would also like to know if you are interested in becoming a volunteer. We need help in **all areas**, so be sure to fill out the entire form.

### PLEASE ADD ME TO YOUR MAILING LIST:

OCT 2005

NAME: \_\_\_\_\_

ADDRESS: \_\_\_\_\_

\_\_\_\_\_ ZIP \_\_\_\_\_

HOME PHONE: \_\_\_\_\_

DAYTIME PHONE: \_\_\_\_\_

E-MAIL ADDRESS: \_\_\_\_\_

MY OCCUPATION: \_\_\_\_\_

MY HOBBIES: \_\_\_\_\_

### YES, I WOULD LIKE TO BE OF HELP. I CAN:

- |   |   |  |
|---|---|--|
| <input type="checkbox"/> Help load in and out for shows | <input type="checkbox"/> Draw and/or paint  | <input type="checkbox"/> Help kids with homework |
| <input type="checkbox"/> Hang lights                    | <input type="checkbox"/> Help with mailings | <input type="checkbox"/> Teach kids a skill      |
| <input type="checkbox"/> Work on a backstage crew       | <input type="checkbox"/> Do office work     | <input type="checkbox"/> Be a chef at an event   |
| <input type="checkbox"/> Do graphic design              | <input type="checkbox"/> Design sound       | <input type="checkbox"/> Design and sew costumes |
| <input type="checkbox"/> Other (please specify) _____   |   |  |

### MY SCHEDULE IS:

- Very flexible. I'm often available during weekdays.  
 Somewhat flexible. I can help on the occasional morning or afternoon during the week.  
 Not very flexible at all, but I've got some free time on evenings and weekends.

If you would like to mail this (and you're always welcome to enclose a tax-deductible contribution), you can send it to: **The 52nd Street Project**, 500 West 52nd St., New York, NY 10019. Or fax it to (212) 333-5598.

## Don't Miss Our Upcoming Shows!

# Oh No, You *DIDN'T!*

Plays that do!

DECEMBER 9-11 AT THE PUBLIC THEATER

In September, 9 brand-new Project kids began a Playmaking class taught by brand-new Playmaking Director Reg Flowers. Come and see their final plays performed by adult professional actors.

# THE TWO-ON -TWO'S

JANUARY, 2006  
AT THE  
WOMEN'S INTERART THEATRE

Dare we let kids act with each other, with no adult in sight? You bet we do! Come see these six new plays in the space across the hall from the Clubhouse.



The 52nd Street Project is a non-profit organization that brings children from the Hell's Kitchen neighborhood together with professional theater artists to create original theater. **CHILL AND SERVE** is a production of our **Playback** program, in which kid actor/playwrights wrote plays that were then "answered" by adult actor/playwright partners who write their own plays. We took the whole menagerie up to the idyllic hamlet of Franklin, NY over the Columbus Day weekend to rehearse the shows. In the final production, which you see here tonight, the partners perform both plays back-to-back. All of the kids involved are veterans of the Playmaking classes which were adapted for the Project by Daniel Judah Sklar from his book *Playmaking: Children Writing and Performing Their Own Plays*.

### The 52nd Street Project Board of Directors

Ben Barenholtz  
Lisa Benavides  
Rachel Chanoff  
Cathy Dantchik  
Wendy Ettinger,  
*chair emeritus*  
Louis P. Friedman  
Stephen Graham, *chair*  
Larry Jones  
James McDaniel  
Frances McDormand  
Noël Mihalow  
Patricia M. Murphy, Esq.

Carol Ochs  
Willie Reale,  
*founder*  
Gus Rogerson  
Shirley Rumierk,  
*alumni member*  
José Soto, Jr.,  
*alumni member*  
Pamala Tyson  
Laura Valeroso  
Wendy vanden Heuvel  
John A. Vassilaros  
Jenny Wiener

### Special Thanks

We're extremely grateful to **Gene, Carol, and Carmela Marner; Tom Duerdon and Xena Sheehan, the Monosson family** and all the folks in Franklin, NY for being such gracious hosts on the weekend away. **Ed Vassallo** gets a foam-core Oscar for arranging the entire expedition.

### In-Kind Contributions

The Murphy Law Office; Benefit Cosmetics; Iris A. Brown; Bourjois Paris; Bumble and bumble; Ron Kastner and Capital Printing; Kenneth Cole Productions; Noggin; Scholastic, Inc.; Diageo Chateau & Estate Wines; Entertainment Weekly; Lucky Magazine; Microtouch/Finishing Touch; Molten Brown; MOP Cosmetics; Newman's Own; Pharma Print/Omni Graphics; Sesame Workshop; Wendy Stuhlberg; Terax America; John A. Vassilaros; Watkins, Inc.; Mayor's Office of Film & Television; Boylan's Bottling Co.; David Sneddon & Fairway Market; Lorraine Tobias & Imaginary Studios; ICI; Jive Records, part of Zomba Music Group; and Prime Films.

## CHILL AND SERVE: THE REVENGE PLAYS ACT I

All original music composed by Loren Toolajian

### GLAMOUROUS AND FANTSY

By Crystal Toro, age 13. Dramaturg/Director: Megan Cramer.

### ALL THE PRETTY LITTLE FLOWERS

Written and directed by Megan Cramer.

Glamour Girl/Rose .....Crystal Toro  
 Fantsy Smantsy Pantsy/Daisy .....Megan Cramer  
 Best Friends .....Megan Corcoran & Kayelani Silva  
 School Kids .....The Crew  
 Mr. Fantastic .....John Sheehy  
 “I’m a Star,” “Just Listen,” “What a Day,” “Just Stay Away,” and “Drama’s Over”  
 lyrics by Crystal Toro.

### I HAD TO DO WHAT I HAD TO DO

By A.J.Welsh, age 12. Dramaturg/Director: Ed Vassallo.

### ACORN’S DILEMMA

Written and directed by Ed Vassallo.

Champ Shanahan .....A.J. Welsh  
 Shockey Buress/Devin Shanahan .....Ed Vassallo  
 Silhouettes .....Anthony Mejia, Kayelani Silva  
 & Kimani Lewis-Ashley

“Cause and Effect” lyrics by Ed Vassallo.

### THE RICH AND THE BUM

By Jonathan Rosario, age 12. Dramaturg/Director: Zakiyyah Alexander.

### FAME AND FORTUNE

Written and directed by Zakiyyah Alexander.

Yo I Don’t Know .....Jonathan Rosario  
 Yo I Do Know .....Zakiyyah Alexander

“The Rap” lyrics by Jonathan Rosario.

### THE BIG MYSTERY

By Janiece Aponte, age 12. Dramaturg/Director: George Babiak.

**SWEET REVENGE** Written and Directed by George Babiak.

Katelyn/Lefty .....Janiece Aponte  
 Anthony/Flash .....George Babiak  
 High School Kids .....The Crew  
 Survivor .....Megan Corcoran  
 Silhouettes .....Megan Cramer & Reg Flowers

“Best Friends Forever” lyrics by Janiece Aponte, “Revenge” lyrics by George Babiak.



## CHILL AND SERVE: THE REVENGE PLAYS ACT II

### THE LESSON OF GIVING

By Dale Fetterman, age 12. Dramaturg/Director: Lizzy Cooper Davis.

### THE GIFT THAT KEEPS ON

By Reg Flowers. Directed by Lizzy Cooper Davis.

Davis .....Dale Fetterman  
 Spirit/Terry Mason .....Lizzy Cooper Davis  
 Policeman .....Reg Flowers  
 Other Cops .....The Crew

“The Break Song” lyrics by Reg Flowers.

### THE YEAH YEAH BRAVE GIRLS

By Merlaine Mendez, age 13. Directed by Patricia Buckley.

### YEAH, YEAH WHATEVER

Written by Reg Flowers and Patricia Buckley. Directed by Patricia Buckley.

Mimi Mister .....Merlaine Mendez  
 Cici Mister .....Patricia Buckley

“The Yeah Yeah Song” and “What Do You Do” lyrics by Merlaine Mendez.

### LAWYERS ALWAYS HAVE A THING FOR FOOTBALL PLAYERS

By Steven Castellanos, age 13. Dramaturg/Director: Jed Clarke.

### MAKE IT RIGHT

Written and directed by Jed Clarke.

Michle .....Steven Castellanos  
 John Ricks .....Jed Clarke

“I’m Sorry” lyrics by Jed Clarke.

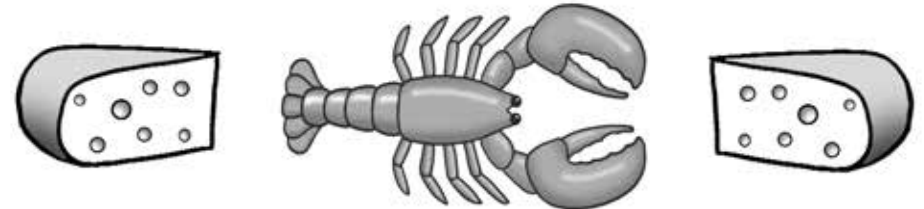

The 52nd Street Project gratefully acknowledges the support of the following foundations and corporations: Stephen & Mary Birch Foundation; Brunswick Group LLP; Capital Research Company; Carnegie Corporation of New York; CBS; Citigroup Foundation; Cityrest, LLC; Clinton Seed Fund; Comedy Central; Consolidated Edison; The Dramatists Guild Fund; Dramatists Play Service; The Fan Fox & Leslie R. Samuels Foundation.; Fox Hollow Technologies, Inc.; The Horace W. Goldsmith Foundation; The Henlopen Foundation; Holland Lodge Foundation; Lloyds TSB Bank plc; Lucille Lortel Foundation; James A. Macdonald Foundation; Ann M. Martin Foundation; Mellon Equity Associated, LLP; Newman's Own; The New York Times Company Foundation; Noggin; People Places, Inc.; Sesame Workshop; Showtime Networks Inc; St. Vincent De Paul Foundation; Stranahan Foundation; The Surdna Foundation; Theatre Communications Group, Inc.; Tiger Baron Foundation; John A. Vassilaros & Son, Inc.; The Vervane Foundation; Weil, Gotshal & Manges LLP; Felix Zaremba & Co. Inc.; Zombaln addition the following individuals made gifts of over \$250 to The 52nd Street Project this past year (list is current as of 7/01/05):

Robert Abrams & Cynthia Vance	Louis & Patrice Friedman	Peter Manning & André Bishop	Mitchell Semel & Colleen Carroll
Jace Alexander & Maddie Coman	Rose Gasner & Larry Chertoff	Sonya Martin	Mitchell Silverman
Alexis Alexanian	John A. Vassilaros &	Robert Matza & Nina Matza	Simone Silverman
Lawrence Alieto	Alexandra Gersten-Vassilaros	Fran McDormand & Joel Coen	Landon Slane
Cecilia Arana-Grant & Kevin Grant	Scott & Laura Gewirtz	Rick Meese & Dan Lori	Jean Stein
Emily Armstrong	Kilty Gilmour	Josie Merck & Jim Stevenson	Barclay Stiff
Ben Barenholtz	Tony Goldwyn & Jane Musky	Audrey & Danny Meyer	Ben & Christine Stiller
Jessica Bauman	Stephen & Cathy Graham	Noël & Joe Mihalow	R.L. Stine & Jane Stine
Lisa Benavides & Tim Nelson	Connie Grappo & Lee Wilkof	Suzen Murakoshi & Mark Temme	Susanna Styron & Darrell Larson
Stephanie Berger & Paul King	Myrna & Stephen Greenberg	Patricia M. Murphy, Esq. & Adam Spilka	Brian Swardstrom & Bonnie Bernstein
Alexander & Elizabeth Bernstein	Michael Greif & Jonathan Fried	Don & Sara Nelson	Richard Sweren
Lewis Black	Emily Grishman & Susan Sampliner	Fred Nelson	Leonard Tow
Andrew Blackman & Tatiana Rutkowski	Lisa Gugenheim & Larry Nathanson	Randy & Rona Nelson	Liz Tuccillo
Richard Blau	Nina Hellman & Jeremy Shamos	James Neuberger & Helen Stambler	John Turturro & Katherine Borowitz
Roger Bolton & Lynne Bolton	Peter Herdrich & Karen Trott	& Helen Stambler	Laura Valeroso & David Seidman
Becky Browder & Ted Neustadt	William Holtzman	Clea Newman	Wendy vanden Heuvel & Brad Coley
Susan Bruce & Peter Hedges	& S. Sylvia Shepard	Kevin O'Rourke & Edith Thurber	Ed Vassallo
Cora Cahan & Bernard Gersten	Katy Homans & Patterson Sims	Carol Ochs & Bruce MacVittie	John A. Vassilaros & Alexandra Gersten- Vassilaros
Rachel Chanoff	Sarah Horowitz & David Venarde	Jacki Ochs & Jan Kroeze	Claudia Wagner
Howard Chatzinoff	Saul Horowitz	Elizabeth Peters	Mary Pat Walsh
Ronald Cohen	Anne & Eli Jackson	Bat-Sheva & Thomas Peters	Borah & Mildred Walton
John Ellison Conlee	LaTanya & Samuel Jackson	Judy Goldman & Michael Pillingier	Lynn & Sam Waterston
Tricia Cooke & Ethan Coen	Sy Jacobs	Peter & Helen Randolph	Sally & Lenny Weiss
Arthur Dantchik	Andrea Johnson	Paul Reale & Barbara McCrane	Jane Bolster & Steve Wertimer
Cathy Dantchik	Kristen Johnston	Willie Reale & Jenny Gersten	Jenny Wiener & Jon Steingart
Leslie Dantchik	Larry & Mary Jones	Lise Rehwaldt & Mark Roberts	Michael & Zena Wiener
Shery Davis & Mark Alhadeff	Jane Kaczmarek	Julie Ridge	Joanne Woodward & Paul Newman
Peter & Judith Dawkins	Cindy Kaplan	David & Anita Rogerson	Jeffrey & Janine Yass
Richard & Rebecca Dresser	Michelle Katz	Shirley Rumierk	Mei Yueh Yen
Nora Ephron	Judy Kuhn & David Schwab	Steve Sabba	
Heidi Ettinger	Stephen Lebovitz	Laura Sametz & Anton Fig	
Wendy Ettinger & Derek McLane	Robert Sean Leonard	Marcia Santoni & John Morris	
Robert Feldman	Liza Lerner	Meredith Beeuwkes	
Peter Jay Fernandez	Michael Loeb & Marjorie Loeb	Karin & Tom Schall	
& Denise Burse	Grace Lyu-Volkhausen	Robert Schnur	
Frank Frattaroli	Greg MacPherson	Maury Schott	
Katherine Freedman	& Jane Perlmutter	Lauren Seikaly & Michael Huber	
	Doda Manalansan		

## THE 52ND STREET PROJECT PRESENTS



## THE 2005 STONE RIDGE PLAYMAKING SERIES

AT THE PUBLIC THEATER  
425 LAFAYETTE ST.

FRI., DEC. 9 AND SAT., DEC. 10 AT 7:30 P.M.,  
SUN., DEC. 11 AT 3:00 P.M.

# OH NO YOU DIDN'T

The Stone Ridge Playmaking Plays - Fall 2005 - Dec. 9-11  
at The Public Theater, 425 Lafayette St.

## The 52nd Street Project Staff:

Gus Rogerson, Artistic Director  
Carol Ochs, Executive Director  
John Sheehy, Director of Development and Marketing  
George "X-Acto" Babiak, Production Manager  
Reg Flowers, Associate Artistic Director  
Liz Bell, Director of Education  
Diana Rojas, Executive Assistant  
Mayleen Cancel, Education Assistant  
Megan Cramer, Education Liaison  
Chris Ceraso, Teen Dean  
Solangee Acosta, Joshua Joya, Johanna Vidal, Receptionists  
Intern: Megan Corcoran

## Production Staff

**Composer:** Patrick Barnes

**Set Designer:** Kevin Joseph Roach

**Lighting Designers:**

Greg MacPherson and  
Doug Filomena

**Costume Designers:**

Chloe Chapin and Abby Redmond

**Sound Designer:** Maury Schott

**Stage Manager:** Patricia MacGregor

**Slide Designers:**

George Babiak, Billie Cohen,  
Mike Sell, and many others

**"Oh No You Didn't" Illustration:**

Reg Flowers

**Prop Design Team:**

George Babiak, Inge Baugh,  
Meredith Blake and her friend

Taylor, Megan Corcoran,

Ben Patton, Rob Steir, Oui Wong

**Furniture Crew:**

Noel Polanco, Christopher Ramirez,  
and Aladino Olivares

**Prop Crew:**

Megan Corcoran and Riji Suh

**Load-in and Light Hang Crew:**

Brian Emens, Ray Harold, Holly  
Kirk, Nick Mele, Ben Patton, Jay  
Scott, Charlie Tocantins

**Playmaking Class Volunteers:**

David Anzuelo, Rebecca  
Bellingham, Megan Corcoran,  
Ephraim Lopez  
and Akyiaa Wilson,

**House Managers:**

Mary Pat Walsh and Liz Bell

**Host/Chefs:**

Joe White, Iris A. Brown, and their  
son Walker

The Playmaking Program is made possible with public funds from The New York State Council on the Arts, a state agency. The 52nd Street Project is a member of Art/NY and a participant in the New Generations Program, funded by Doris Duke Charitable Foundation/The Andrew W. Mellon Foundation and administered by Theatre Communications Group, the national organization for the American Theater.



# COOL STUFF ON SALE!

Flyer Bars .....\$2.00, \$1.50 & \$1.00  
"Playmaking" by Daniel Judah Sklar .....\$15.00

*Shel Silverstein's "Fivey and Twoey" logo gear:*

Project "Hoodies" (NEW!) .....\$30.00  
Project Caps .....\$15.00  
Project Mugs .....\$5.00  
Project Notebooks .....\$5.00  
Project Pencil 3-pack (NEW COLOR!) ...\$1.00

Thank you for coming to **OH NO YOU DIDN'T**. If you are not on our mailing list (or if your address has changed), please fill out this form and give it to us on your way out or mail it to the address below. We would also like to know if you are interested in becoming a volunteer. We need help in **all areas**, so be sure to fill out the entire form.

**PLEASE ADD ME TO YOUR MAILING LIST:**

12/05

NAME: \_\_\_\_\_

ADDRESS: \_\_\_\_\_

ZIP \_\_\_\_\_

HOME PHONE: \_\_\_\_\_

DAYTIME PHONE: \_\_\_\_\_

E-MAIL ADDRESS: \_\_\_\_\_

MY OCCUPATION: \_\_\_\_\_

MY HOBBIES: \_\_\_\_\_

**YES, I WOULD LIKE TO BE OF HELP. I CAN:**

- |   |   |  |
|---|---|--|
| <input type="checkbox"/> Help load in and out for shows | <input type="checkbox"/> Draw and/or paint  | <input type="checkbox"/> Help kids with homework |
| <input type="checkbox"/> Hang lights                    | <input type="checkbox"/> Help with mailings | <input type="checkbox"/> Teach kids a skill      |
| <input type="checkbox"/> Work on a backstage crew       | <input type="checkbox"/> Do office work     | <input type="checkbox"/> Be a chef at an event   |
| <input type="checkbox"/> Do graphic design              | <input type="checkbox"/> Design sound       | <input type="checkbox"/> Design and sew costumes |
| <input type="checkbox"/> Other (please specify) _____   |   |  |

**MY SCHEDULE IS:**

- Very flexible. I'm often available during weekdays.  
 Somewhat flexible. I can help on the occasional morning or afternoon during the week.  
 Not very flexible at all, but I've got some free time on evenings and weekends.

If you would like to mail this (and you're always welcome to enclose a tax-deductible contribution), you can send it to: **The 52nd Street Project**, 500 West 52nd St., New York, NY 10019. Or fax it to (212) 333-5598.

## Don't Miss Our Upcoming Shows!

# WHICH WAY DID THEY GO?

## THEATRICAL PURSUITS

The 2006 2-on-2's - January 27, 28, and 29

at

The Women's  
Interart Annex,  
500 W. 52nd St.

Just across the  
hall from the  
Clubhouse!



6 new plays, each with two kids as performers and two adults as writers and directors. Come watch the kids go it alone on stage!

# Any Day Now!

## PLAYS WORTH WAITING FOR



The Spring Edition of the  
Project's Playmaking Program

At a theater to be announced  
(If you have one we can use, tell us!)

If you're enjoying the show tonight, you'll want to take in another set of shows by our *next* batch of Project newcomers! Call 642-5052 for reservations.

The 52nd Street Project is a non-profit organization that brings children from the Hell's Kitchen neighborhood together with professional theater artists to create original theater. **OH NO YOU DIDN'T** is a production of our Playmaking program. Young people participate in a nine-week playwriting course taught by Megan Sandberg-Zakian and adapted for the Project by Daniel Judah Sklar from his book *Playmaking: Children Writing and Performing Their Own Plays*. At the end of the course, each child is given two actors, a theme, and a dramaturg/director who guides him or her through the writing of a play during a weekend retreat in the country (Kripplebush, New York, for this show). Tonight's performance is the end result.

### The 52nd Street Project Board of Directors

Ben Barenholtz  
Lisa Benavides  
Rachel Chanoff  
Cathy Dantchik  
Noël Dawkins  
Wendy Ettinger,  
*chair emeritus*  
Louis P. Friedman  
Stephen Graham, *chair*  
Larry Jones  
James McDaniel  
Frances McDormand  
Patricia M. Murphy, Esq.

Carol Ochs  
Willie Reale,  
*founder*  
Gus Rogerson  
Shirley Rumierk,  
*alumni member*  
José Soto, Jr.,  
*alumni member*  
Pamala Tyson  
Laura Valeroso  
Wendy vanden Heuvel  
John A. Vassilaros  
Jenny Wiener

### Special Thanks

We're extremely grateful to **Steve Gorn**, **Barbara Bash** and their son **Wiley**, who graciously allowed us to use their beautiful home in Stone Ridge, NY as our base of operations for the writer's retreat. We also owe a mini-van load of gratitude to **Joe White** and **Iris Brown** for cooking some mighty big (and good) meals and lining up all the other host families (who earn thanks as well). They were **Laura Shaine Cunningham**, **Mary Louise Wilson**, **Nicole** and **Paul Quinn**, **Deborah Freedman**, **Bill Woods**, and **Charles Miles** and **Naomi Freundlich**, and **Jason Downs** and **Sophia Rabb**. Finally, a big box of thanks go to **Oskar Eustis**, **Maria Goyanes**, **Christina Hale**, Al Clancy, and everyone else at the terrific **Public Theater**. We're very honored to be here!

### In-Kind Contributions

The Murphy Law Office; Benefit Cosmetics; Iris A. Brown; Bourjois Paris; Bumble and bumble; Ron Kastner and Capital Printing; Kenneth Cole Productions; Noggin; Scholastic, Inc.; Diageo Chateau & Estate Wines; Entertainment Weekly; Lucky Magazine; Microtouch/Finishing Touch; Molten Brown; MOP Cosmetics; Newman's Own; Pharma Print/Omni Graphics; Sesame Workshop; Wendy Stuhlberg; Terax America; John A. Vassilaros; Watkins, Inc.; Mayor's Office of Film & Television; Boylan's Bottling Co.; David Sneddon & Fairway Market; Lorraine Tobias & Imaginary Studios; ICI; Jive Records, part of Zomba Music Group; and Prime Films.

# OH NO YOU DIDN'T! - ACT 1

All original music composed by Patrick Barnes

## The Best Friends

by Breanna Straker, age 9. Dramaturg/Director: Maria Goyanes  
Costume Designer: Abby Redmond

Pencil Project .....Jeanine Serralles  
Big Black Eraser .....Mia Barron

“Mean” lyrics by Breanna Straker

## The Lock-Up

by Terrence Mack, age 11. Dramaturg/Director: John Sheehy  
Costume Designer: Abby Redmond

Young Ron .....Kenajuan Bentley  
Officer Bang .....Nancy Giles  
Joe .....Michael Potts

“Dead Man” lyrics by Terrence Mack

## Feeling Good

by Zakiya Jacob, age 9. Dramaturg/Director: Jessica Bauman  
Costume Designer: Chloe Chapin

Smiley .....Josh Hamilton  
Feala .....Megan Cramer  
Voice of the Painter .....Christopher Ramirez

“You Can’t Erase Me” and “Friends” lyrics by Zakiya Jacob

## Foolish Mortals, Magical Powers

by Marlowe Mendez, age 9. Dramaturg/Director: Claudia Zelevansky  
Costume Designer: Abby Redmond

Bad Guy/Dad .....Reg Flowers  
Prey .....Akyiaa Wilson

“You and Me” lyrics by Marlowe Mendez

## The Man, The Monkey, So Funny

by Chris Tineo, age 9. Dramaturg/Director: Jonathan Bernstein  
Costume Designer: Chloe Chapin

Smart Monkey .....Christopher Randolph  
The Man .....Danyon Davis  
The Nurse .....Riji Suh

“The Rhyming Song” and “The Rhyming Song Reprise” lyrics by Chris Tineo

👉 **Intermission!** 👈

# PLAYS THAT DO! - ACT II

## The War with the Barbies and Legoes

by Kyone Murphy, age 9. Dramaturg/Director: Kate Marks  
Costume Designer: Chloe Chapin

Max .....Bill Camp  
Rudy .....Ray Anthony Thomas  
Newscaster .....Noel Polanco  
Super .....Riji Suh

“This Is My War” lyrics by Kyone Murphy

## Sam and Samantha’s Friendship

by Chloe Moore, age 10. Dramaturg/Director: Glynis Rigsby  
Costume Designer: Abby Redmond

Samantha .....Cecilia Arana  
Sam .....Ephraim Lopez

“We’re Friends” lyrics by Chloe Moore

## The Halloween Night

by Nequai Figueroa, age 10. Dramaturg/Director: Michael Potts  
Costume Designer: Abby Redmond

Ciara .....Mary Louise Wilson  
Megan .....Florencia Lozano  
Landlord .....George Babiak

## Lost In The Woods

by Andy Reyes, age 9. Dramaturg/Director: Danny Goldstein  
Costume Designer: Chloe Chapin

Mucha Lucha .....Kevin Geer  
Deery .....Edie Falco  
Voice of Mucha Lucha’s Mother .....Reg Flowers  
Voice of Mucha Lucha Never Wanna Be .....Reg Flowers

“Mucha Lucha Never Wanna Be’s Song” and “Have Fun” lyrics by Andy Reyes



*We wish a very  
happy holiday  
season to all  
Projectiles,  
great and small!*